

---

# Trueform Arbitrary Waveform Generator

EDU33210 Series

<b>Notices</b> .....	<b>12</b>
<b>Copyright Notice</b> .....	<b>12</b>
<b>Manual Part Number</b> .....	<b>12</b>
<b>Edition</b> .....	<b>12</b>
<b>Published by</b> .....	<b>12</b>
<b>Warranty</b> .....	<b>12</b>
<b>Technology Licenses</b> .....	<b>12</b>
<b>U.S. Government Rights</b> .....	<b>13</b>
<b>Third Party Licenses</b> .....	<b>13</b>
<b>Waste Electrical and Electronic Equipment (WEEE)</b> .....	<b>13</b>
<b>Declarations of Conformity</b> .....	<b>14</b>
<b>Safety Information</b> .....	<b>14</b>
<b>1 Remote Operation</b> .....	<b>15</b>
<b>Introduction to the SCPI Language</b> .....	<b>16</b>
Syntax Conventions .....	16
Command Separators .....	17
Using the MIN, MAX, and DEF Parameters .....	17
Querying Parameter Settings .....	17
SCPI Command Terminators .....	18
IEEE-488.2 Common Commands .....	18
SCPI Parameter Types .....	18
Using Device Clear .....	20
<b>Instrument Models</b> .....	<b>20</b>
<b>Internal Function Waveforms</b> .....	<b>20</b>
<b>Maximum Waveform Frequencies by Model</b> .....	<b>22</b>
EDU33211A and EDU33212A .....	22
<b>SCPI Error Messages</b> .....	<b>23</b>
<b>Factory Reset State</b> .....	<b>34</b>
<b>SCPI Status Registers</b> .....	<b>39</b>
What is an event register? .....	39
What is a condition register? .....	40
What is an enable register? .....	40
The Questionable Data register .....	40
The Standard Operation register .....	41
The Standard Event register .....	41
The Status Byte register .....	43
<b>Programming Examples</b> .....	<b>44</b>
Configure a Sine Wave .....	45
Configure a Square Wave .....	45
Configure a Ramp Wave .....	46
Configure a Pulse Wave .....	47
Create a List of Frequencies .....	48
Configure an arbitrary waveform .....	48
<b>2 SCPI Programming</b> .....	<b>50</b>
<b>ABORt Subsystem</b> .....	<b>51</b>
ABORt .....	52
<b>CALibration Subsystem</b> .....	<b>53</b>
CALibration[:ALL]? .....	54
CALibration:COUNT? .....	54
CALibration:SECure:CODE <new_code> .....	55

CALibration:SECure:STATe ON 1 OFF 0,<code> .....	55
CALibration:SECure:STATe? .....	55
CALibration:SETup <step> .....	56
CALibration:SETup? .....	56
CALibration:STRing "<string>" .....	56
CALibration:STRing? .....	56
CALibration:VALue <value> .....	56
CALibration:VALue? .....	56
<b>DISPlay Subsystem .....</b>	<b>57</b>
DISPlay ON 1 OFF 0 .....	58
DISPlay? .....	58
<b>FORMat Subsystem .....</b>	<b>59</b>
FORMat:BORDer NORMal SWAPped .....	60
FORMat:BORDer? .....	60
<b>HCOPy Subsystem .....</b>	<b>61</b>
HCOPy:SDUMp:DATA? .....	62
HCOPy:SDUMp:DATA:FORMat BMP .....	62
HCOPy:SDUMp:DATA:FORMat? .....	62
<b>IEEE-488 Common Commands .....</b>	<b>63</b>
*CLS .....	64
*ESE <enable_value> .....	64
*ESE? .....	64
*ESR? .....	64
*IDN? .....	65
*OPC .....	65
*OPC? .....	66
*PSC 0 1 .....	66
*PSC? .....	66
*RCL 0 1 2 3 4 .....	67
*SAV 0 1 2 3 4 .....	67
*RST .....	67
*SRE <enable_value> .....	68
*SRE? .....	68
*STB? .....	68
*TRG .....	69
*TST? .....	69
*WAI .....	69
<b>INITiate Subsystem .....</b>	<b>70</b>
INITiate[1 2]:CONTInuous ON 1 OFF 0 .....	71
INITiate[1 2]:CONTInuous? .....	71
INITiate:CONTInuous:ALL ON 1 OFF 0 .....	71
INITiate[1 2][:IMMediate] .....	72
INITiate[:IMMediate]:ALL .....	72
<b>LXI Subsystem .....</b>	<b>73</b>
LXI:IDENtify[:STATE] ON 1 OFF 0 .....	74
LXI:IDENtify[:STATE]? .....	74
LXI:MDNS:ENABle ON 1 OFF 0 .....	74
LXI:MDNS:ENABle? .....	74
LXI:MDNS[:STATe] ON 1 OFF 0 .....	74
LXI:MDNS[:STATe]? .....	74
LXI:MDNS:HNAME[:RESolved]? .....	74
LXI:MDNS:SNAME:DESired <name> .....	75

LXI:MDNS:SNAME:DESired?	75
LXI:MDNS:SNAME[:RESolved]?	75
LXI:RESet	75
LXI:REStart	76
<b>MEMory Subsystem</b>	<b>77</b>
MEMory:NStates?	78
MEMory:StAtE:CATalog?	78
MEMory:StAtE:DELeTe 0 1 2 3 4	78
MEMory:StAtE:NAME 0 1 2 3 4 [<name>]	79
MEMory:StAtE:NAME? 0 1 2 3 4	79
MEMory:StAtE:RECall:AUTO ON 1 OFF 0	79
MEMory:StAtE:RECall:AUTO?	79
MEMory:StAtE:VALid? 0 1 2 3 4	79
<b>MMEMory Subsystem</b>	<b>80</b>
MMEMory:CATalog[:ALL]? [<folder>]	84
MMEMory:CATalog:DATA:ARBitrary? [<folder>]	85
MMEMory:CATalog:StAtE? [<folder>]	85
MMEMory:CDIRectory <folder>	86
MMEMory:CDIRectory?	86
MMEMory:MDIRectory <folder>	86
MMEMory:RDIRectory <folder>	86
MMEMory:COpy <file1>,<file2>	86
MMEMory:DELeTe <file>	87
MMEMory:DOWNload:DATA <binary_block>	87
MMEMory:DOWNload:FNAME <filename>	87
MMEMory:DOWNload:FNAME?	87
MMEMory:LOAD:ALL <filename>	88
MMEMory:StORe:ALL <filename>	88
MMEMory:LOAD:DATA[1 2] <filename>	88
MMEMory:LOAD:LIST[1 2] <filename>	89
MMEMory:StORe:LIST[1 2] <filename>	89
MMEMory:LOAD:StAtE <filename>	89
MMEMory:StORe:StAtE <filename>	89
MMEMory:MOVE <file1>,<file2>	90
MMEMory:StORe:DATA[1 2] <filename>	90
MMEMory:UPLoad? <filename>	91
<b>OUTPut Subsystem</b>	<b>92</b>
OUTPut[1 2]::StAtE] ON 1 OFF 0	93
OUTPut[1 2]::StAtE]?	93
OUTPut[1 2]:LOAD <ohms> INFinity MINimum MAXimum DEFault	94
OUTPut[1 2]:LOAD? [MINimum MAXimum]	94
OUTPut[1 2]:MODE NORMal GATed	95
OUTPut[1 2]:MODE?	95
OUTPut[1 2]:POLarity NORMal INVerted	95
OUTPut[1 2]:POLarity?	95
OUTPut:SYNC[:StAtE] ON 1 OFF 0	96
OUTPut:SYNC[:StAtE]?	96
OUTPut[1 2]:SYNC:MODE NORMal CARRier MARKer	97
OUTPut[1 2]:SYNC:MODE?	97
OUTPut[1 2]:SYNC:POLarity NORMal INVerted	98
OUTPut[1 2]:SYNC:POLarity?	98
OUTPut:SYNC:SOURce CH1 CH2	98

OUTPut:SYNC:SOURce? .....	98
OUTPut:TRIGger[:STATe] ON 1 OFF 0 .....	99
OUTPut:TRIGger[:STATe]? .....	99
OUTPut:TRIGger:SLOPe POSitive NEGative .....	100
OUTPut:TRIGger:SLOPe? .....	100
OUTPut:TRIGger:SOURce CH1 CH2 .....	100
OUTPut:TRIGger:SOURce? .....	100
<b>SOURce Subsystem .....</b>	<b>101</b>
<b>AM Subsystem .....</b>	<b>103</b>
[SOURce[1 2]:]AM[:DEPT]h <depth_in_percent> MINimum MAXimum DEFault .....	104
[SOURce[1 2]:]AM[:DEPT]h? [MINimum MAXimum DEFault] .....	104
[SOURce[1 2]:]AM:DSSC ON 1 OFF 0 .....	104
[SOURce[1 2]:]AM:DSSC? .....	104
[SOURce[1 2]:]AM:INTernal:FREQuency <frequency> MINimum MAXimum DEFault .....	105
[SOURce[1 2]:]AM:INTernal:FREQuency? MINimum MAXimum .....	105
[SOURce[1 2]:]AM:INTernal:FUNCTion <function> .....	105
[SOURce[1 2]:]AM:INTernal:FUNCTion? .....	105
[SOURce[1 2]:]AM:SOURce INTernal CH1 CH2 .....	106
[SOURce[1 2]:]AM:SOURce? .....	106
[SOURce[1 2]:]AM:STATe ON 1 OFF 0 .....	106
[SOURce[1 2]:]AM:STATe? .....	106
<b>APPLy Subsystem .....</b>	<b>107</b>
[SOURce[1 2]:]APPLy? .....	109
[SOURce[1 2]:]APPLy:ARBITrary [<sample_rate> MINimum MAXimum DEFault [, <amp- litude> MINimum MAXimum DEFault [, <offset> MINimum MAXimum DEFault]]] .....	110
[SOURce[1 2]:]APPLy:DC [<frequency> MINimum MAXimum DEFault [, <amp- litude> MINimum MAXimum DEFault [, <offset> MINimum MAXimum DEFault]]] .....	111
[SOURce[1 2]:]APPLy:NOISe [<frequency> MINimum MAXimum DEFault [, <amp- litude> MINimum MAXimum DEFault [, <offset> MINimum MAXimum DEFault]]] .....	112
[SOURce[1 2]:]APPLy:PRBS [<frequency> MINimum MAXimum DEFault [, <amp- litude> MINimum MAXimum DEFault [, <offset> MINimum MAXimum DEFault]]] .....	113
[SOURce[1 2]:]APPLy:PULSe [<frequency> MINimum MAXimum DEFault [, <amp- litude> MINimum MAXimum DEFault [, <offset> MINimum MAXimum DEFault]]] .....	114
[SOURce[1 2]:]APPLy:RAMP [<frequency> MINimum MAXimum DEFault [, <amp- litude> MINimum MAXimum DEFault [, <offset> MINimum MAXimum DEFault]]] .....	115
[SOURce[1 2]:]APPLy:TRlangle [<frequency> MINimum MAXimum DEFault [, <amp- litude> MINimum MAXimum DEFault [, <offset> MINimum MAXimum DEFault]]] .....	115
[SOURce[1 2]:]APPLy:SINusoid [<frequency> MINimum MAXimum DEFault [, <amp- litude> MINimum MAXimum DEFault [, <offset> MINimum MAXimum DEFault]]] .....	116
[SOURce[1 2]:]APPLy:SQUare [<frequency> MINimum MAXimum DEFault [, <amp- litude> MINimum MAXimum DEFault [, <offset> MINimum MAXimum DEFault]]] .....	117
<b>BPSK Subsystem .....</b>	<b>118</b>
[SOURce[1 2]:]BPSK:INTernal:RATE <modulating_frequency> MINimum MAXimum DEFault .....	119
[SOURce[1 2]:]BPSK:INTernal:RATE? [MINimum MAXimum] .....	119
[SOURce[1 2]:]BPSK[:PHASe] <angle> MINimum MAXimum DEFault .....	119
[SOURce[1 2]:]BPSK[:PHASe]? [MINimum MAXimum] .....	119
[SOURce[1 2]:]BPSK:SOURce INTernal EXTernal .....	120
[SOURce[1 2]:]BPSK:SOURce? .....	120
[SOURce[1 2]:]BPSK:STATe ON 1 OFF 0 .....	121
[SOURce[1 2]:]BPSK:STATe? .....	121
<b>BURSt Subsystem .....</b>	<b>122</b>

[SOURce[1 2]:]BURSt:GATE:POLarity NORMal INVerted	124
[SOURce[1 2]:]BURSt:GATE:POLarity?	124
[SOURce[1 2]:]BURSt:INTernal:PERiod <seconds> MINimum MAXimum DEFault	124
[SOURce[1 2]:]BURSt:INTernal:PERiod? [MINimum MAXimum]	124
[SOURce[1 2]:]BURSt:MODE TRIGgered GATed	125
[SOURce[1 2]:]BURSt:MODE?	125
[SOURce[1 2]:]BURSt:NCYCles <num_cycles> INFinity MINimum MAXimum	126
[SOURce[1 2]:]BURSt:NCYCles? [MINimum MAXimum]	126
[SOURce[1 2]:]BURSt:PHASe <angle> MINimum MAXimum DEFault	127
[SOURce[1 2]:]BURSt:PHASe? [MINimum MAXimum]	127
[SOURce[1 2]:]BURSt:STATe ON 1 OFF 0	127
[SOURce[1 2]:]BURSt:STATe?	127
<b>COMBine:FEED</b>	<b>128</b>
[SOURce[1 2]:]COMBine:FEED CH1 CH2 NONE	128
[SOURce[1 2]:]COMBine:FEED?	128
<b>DATA Subsystem</b>	<b>130</b>
[SOURce[1 2]:]DATA:ARBitrary2:FORMat AABb ABAB	131
[SOURce[1 2]:]DATA:ARBitrary[1 2] <arb_name>, <binary_block> <value>{, <value>}	132
[SOURce[1 2]:]DATA:ARBitrary[1 2]:DAC <arb_name>, <binary_block> <value>{, <value>}	132
[SOURce[1 2]:]DATA:ATTRibute:AVERage? [<arb_name>]	133
[SOURce[1 2]:]DATA:ATTRibute:CFACTOR? [<arb_name>]	134
[SOURce[1 2]:]DATA:ATTRibute:POINts? [<arb_name>]	134
[SOURce[1 2]:]DATA:ATTRibute:PTPeak? [<arb_name>]	135
[SOURce[1 2]:]DATA:VOLatile:CATalog?	135
[SOURce[1 2]:]DATA:VOLatile:CLEar	135
[SOURce[1 2]:]DATA:VOLatile:FREE?	136
<b>FM Subsystem</b>	<b>137</b>
[SOURce[1 2]:]FM[:DEVIation] <peak_deviation_in_Hz> MINimum MAXimum DEFault	138
[SOURce[1 2]:]FM[:DEVIation]? [MINimum MAXimum]	138
[SOURce[1 2]:]FM:INTernal:FREQuency <frequency> MINimum MAXimum DEFault	139
[SOURce[1 2]:]FM:INTernal:FREQuency? [MINimum MAXimum]	139
[SOURce[1 2]:]FM:INTernal:FUNCTion <function>	139
[SOURce[1 2]:]FM:INTernal:FUNCTion?	139
[SOURce[1 2]:]FM:SOURce INTernal CH1 CH2	140
[SOURce[1 2]:]FM:SOURce?	140
[SOURce[1 2]:]FM:STATe ON 1 OFF 0	140
[SOURce[1 2]:]FM:STATe?	140
<b>FREQuency Subsystem</b>	<b>141</b>
[SOURce[1 2]:]FREQuency <frequency> MINimum MAXimum DEFault	142
[SOURce[1 2]:]FREQuency? [MINimum MAXimum]	142
[SOURce[1 2]:]FREQuency:CENTer <frequency> MINimum MAXimum DEFault	142
[SOURce[1 2]:]FREQuency:CENTer? [MINimum MAXimum]	142
[SOURce[1 2]:]FREQuency:COUple[:STATe] ON 1 OFF 0	143
[SOURce[1 2]:]FREQuency:COUple[:STATe]?	143
[SOURce[1 2]:]FREQuency:COUple:MODE OFFSet RATio	143
[SOURce[1 2]:]FREQuency:COUple:MODE?	143
[SOURce[1 2]:]FREQuency:COUple:OFFSet <frequency> MINimum MAXimum DEFault	144
[SOURce[1 2]:]FREQuency:COUple:OFFSet?	144
[SOURce[1 2]:]FREQuency:COUple:RATio <ratio> MINimum MAXimum DEFault	145
[SOURce[1 2]:]FREQuency:COUple:RATio? MINimum MAXimum	145
[SOURce[1 2]:]FREQuency:MODE CW LIST SWEep FIXed	145
[SOURce[1 2]:]FREQuency:MODE?	145

[SOURce[1 2]:]FREQUency:SPAN <frequency> MINimum MAXimum DEFault	146
[SOURce[1 2]:]FREQUency:SPAN? [MINimum MAXimum]	146
[SOURce[1 2]:]FREQUency:START <frequency> MINimum MAXimum DEFault	146
[SOURce[1 2]:]FREQUency:START? [MINimum MAXimum]	146
[SOURce[1 2]:]FREQUency:STOP <frequency> MINimum MAXimum DEFault	146
[SOURce[1 2]:]FREQUency:STOP? [MINimum MAXimum]	146
<b>FSKey Subsystem</b>	<b>147</b>
[SOURce[1 2]:]FSKey:FREQUency <frequency> MINimum MAXimum DEFault	148
[SOURce[1 2]:]FSKey:FREQUency? [MINimum MAXimum]	148
[SOURce[1 2]:]FSKey:INTernal:RATE <rate_in_Hz> MINimum MAXimum DEFault	148
[SOURce[1 2]:]FSKey:INTernal:RATE? [MINimum MAXimum]	148
[SOURce[1 2]:]FSKey:SOURce INTernal EXTernal	149
[SOURce[1 2]:]FSKey:SOURce?	149
[SOURce[1 2]:]FSKey:STATe ON 1 OFF 0	150
[SOURce[1 2]:]FSKey:STATe?	150
<b>FUNCTION Subsystem</b>	<b>151</b>
[SOURce[1 2]:]FUNCTion <function>	152
[SOURce[1 2]:]FUNCTion?	152
[SOURce[1 2]:]FUNCTion:ARBItrary <filename>	153
[SOURce[1 2]:]FUNCTion:ARBItrary?	153
[SOURce[1 2]:]FUNCTion:ARBItrary:ADVance TRIGger SRATe	154
[SOURce[1 2]:]FUNCTion:ARBItrary:ADVance?	154
[SOURce[1 2]:]FUNCTion:ARBItrary:FILTer NORMal STEP OFF	154
[SOURce[1 2]:]FUNCTion:ARBItrary:FILTer?	154
[SOURce[1 2]:]FUNCTion:ARBItrary:FREQUency <frequency> MINimum MAXimum DEFault	155
[SOURce[1 2]:]FUNCTion:ARBItrary:FREQUency? MINimum MAXimum	155
[SOURce[1 2]:]FUNCTion:ARBItrary:PERiod <period> MINimum MAXimum DEFault	155
[SOURce[1 2]:]FUNCTion:ARBItrary:PERiod? MINimum MAXimum	155
[SOURce[1 2]:]FUNCTion:ARBItrary:POINTs?	156
[SOURce[1 2]:]FUNCTion:ARBItrary:PTPeak <voltage> MINimum MAXimum DEFault	157
[SOURce[1 2]:]FUNCTion:ARBItrary:PTPeak? [MINimum MAXimum]	157
[SOURce[1 2]:]FUNCTion:ARBItrary:SRATe <sample_rate> MINimum MAXimum DEFault	158
[SOURce[1 2]:]FUNCTion:ARBItrary:SRATe? MINimum MAXimum	158
[SOURce[1 2]:]FUNCTion:ARBItrary:SYNChronize	159
[SOURce[1 2]:]FUNCTion:NOISe:BANDwidth BWIDth <bandwidth> MINimum MAXimum DEFault	160
[SOURce[1 2]:]FUNCTion:NOISe:{BANDwidth BWIDth}? [MINimum MAXimum]	160
[SOURce[1 2]:]FUNCTion:PRBS:BRATe <bit_rate>  MINimum MAXimum DEFault	160
[SOURce[1 2]:]FUNCTion:PRBS:BRATe? [MINimum MAXimum]	160
[SOURce[1 2]:]FUNCTion:PRBS:DATA <sequence_type>	161
[SOURce[1 2]:]FUNCTion:PRBS:DATA?	161
[SOURce[1 2]:]FUNCTion:PRBS:TRANSition[:BOTH] <seconds> MINimum MAXimum DEFault	163
[SOURce[1 2]:]FUNCTion:PRBS:TRANSition[:BOTH]? [MINimum MAXimum]	163
[SOURce[1 2]:]FUNCTion:PULSe:DCYClE <percent> MINimum MAXimum DEFault	164
[SOURce[1 2]:]FUNCTion:PULSe:DCYClE? [MINimum MAXimum]	164
[SOURce[1 2]:]FUNCTion:PULSe:HOLD WIDTH DCYClE	165
[SOURce[1 2]:]FUNCTion:PULSe:HOLD?	165
[SOURce[1 2]:]FUNCTion:PULSe:PERiod <seconds> MINimum MAXimum DEFault	166
[SOURce[1 2]:]FUNCTion:PULSe:PERiod? [MINimum MAXimum]	166
[SOURce[1 2]:]FUNCTion:PULSe:TRANSition[:BOTH] <seconds> MINimum MAXimum DEFault	167
[SOURce[1 2]:]FUNCTion:PULSe:TRANSition:LEADing <seconds> MINimum MAXimum DEFault	167
[SOURce[1 2]:]FUNCTion:PULSe:TRANSition:LEADing? [MINimum MAXimum]	167
[SOURce[1 2]:]FUNCTion:PULSe:TRANSition:TRAILing <seconds> MINimum MAXimum DEFault	167

[SOURce[1 2]:]FUNcTion:PULSe:TRANsition:TRAILing? [MINimum MAXimum]	167
[SOURce[1 2]:]FUNcTion:PULSe:WIDTh <seconds> MINimum MAXimum DEFault	168
[SOURce[1 2]:]FUNcTion:PULSe:WIDTh? [MINimum MAXimum]	168
[SOURce[1 2]:]FUNcTion:RAMP:SYMMetry <percent> MINimum MAXimum DEFault	169
[SOURce[1 2]:]FUNcTion:RAMP:SYMMetry? [MINimum MAXimum]	169
[SOURce[1 2]:]FUNcTion:SQUare:DCYClE <percent> MINimum MAXimum DEFault	170
[SOURce[1 2]:]FUNcTion:SQUare:DCYClE? [MINimum MAXimum]	170
[SOURce[1 2]:]FUNcTion:SQUare:PERiod <seconds> MINimum MAXimum DEFault	171
[SOURce[1 2]:]FUNcTion:SQUare:PERiod? [MINimum MAXimum]	171
<b>LIST Subsystem</b>	<b>172</b>
[SOURce[1 2]:]LIST:DWELL <seconds> MINimum MAXimum	173
[SOURce[1 2]:]LIST:DWELL? [MINimum MAXimum]	173
[SOURce[1 2]:]LIST:FREQUency <freq1>[{, <freq2>}]	173
[SOURce[1 2]:]LIST:FREQUency?	173
[SOURce[1 2]:]LIST:FREQUency:POINts? [MINimum MAXimum]	173
<b>MARKer Subsystem</b>	<b>174</b>
[SOURce[1 2]:]MARKer:CYClE <cycle_num> MINimum MAXimum DEFault	175
[SOURce[1 2]:]MARKer:CYClE? [MINimum MAXimum]	175
[SOURce[1 2]:]MARKer:FREQUency <frequency> MINimum MAXimum DEFault	175
[SOURce[1 2]:]MARKer:FREQUency? [MINimum MAXimum]	175
[SOURce[1 2]:]MARKer:POINt <sample_number> MINimum MAXimum	176
[SOURce[1 2]:]MARKer:POINt? [MINimum MAXimum]	176
<b>PHASe Subsystem</b>	<b>177</b>
[SOURce[1 2]:]PHASe <angle> MINimum MAXimum DEFault	178
[SOURce[1 2]:]PHASe? [MINimum MAXimum]	178
[SOURce[1 2]:]PHASe:REFerence	178
[SOURce[1 2]:]PHASe:SYNChronize	179
[SOURce[1]:]PHASe:UNLock:ERRor:STATe ON 1 OFF 0	179
[SOURce[1]:]PHASe:UNLock:ERRor:STATe?	179
<b>PM Subsystem</b>	<b>180</b>
[SOURce[1 2]:]PM:DEViation <deviation in degrees> MINimum MAXimum DEFault	181
[SOURce[1 2]:]PM:DEViation? [MINimum MAXimum]	181
[SOURce[1 2]:]PM:INTernal:FREQUency <frequency> MINimum MAXimum DEFault	181
[SOURce[1 2]:]PM:INTernal:FREQUency? [MINimum MAXimum]	181
[SOURce[1 2]:]PM:INTernal:FUNcTion <function>	182
[SOURce[1 2]:]PM:INTernal:FUNcTion?	182
[SOURce[1 2]:]PM:SOURce INTernal CH1 CH2	182
[SOURce[1 2]:]PM:SOURce?	182
[SOURce[1 2]:]PM:STATe ON 1 OFF 0	183
[SOURce[1 2]:]PM:STATe?	183
<b>PWM Subsystem</b>	<b>184</b>
[SOURce[1 2]:]PWM:DEViation <deviation> MINimum MAXimum DEFault	185
[SOURce[1 2]:]PWM:DEViation? [MINimum MAXimum]	185
[SOURce[1 2]:]PWM:DEViation:DCYClE <deviation_in_pct> MINimum MAXimum DEFault	186
[SOURce[1 2]:]PWM:DEViation:DCYClE? [MINimum MAXimum]	186
[SOURce[1 2]:]PWM:INTernal:FREQUency <frequency> MINimum MAXimum DEFault	187
[SOURce[1 2]:]PWM:INTernal:FREQUency? [MINimum MAXimum]	187
[SOURce[1 2]:]PWM:INTernal:FUNcTion <function>	187
[SOURce[1 2]:]PWM:INTernal:FUNcTion?	187
[SOURce[1 2]:]PWM:SOURce INTernal CH1 CH2	188
[SOURce[1 2]:]PWM:SOURce?	188
[SOURce[1 2]:]PWM:STATe ON 1 OFF 0	188



[SOURce[1 2]:]PWM:STATe? .....	188
<b>RATE Subsystem .....</b>	<b>189</b>
[SOURce[1 2]:]RATE:COUPlE[:STATe] ON 1 OFF 0 .....	190
[SOURce[1 2]:]RATE:COUPlE[:STATe]? .....	190
[SOURce[1 2]:]RATE:COUPlE:MODE OFFSet RATio .....	190
[SOURce[1 2]:]RATE:COUPlE:MODE? .....	190
[SOURce[1 2]:]RATE:COUPlE:OFFSet <sample_rate> MINimum MAXimum DEFault .....	191
[SOURce[1 2]:]RATE:COUPlE:OFFSet? .....	191
[SOURce[1 2]:]RATE:COUPlE:RATio <ratio> MINimum MAXimum DEFault .....	192
[SOURce[1 2]:]RATE:COUPlE:RATio? [MINimum MAXimum] .....	192
<b>SUM Subsystem .....</b>	<b>193</b>
[SOURce[1 2]:]SUM:AMPLitude <amplitude> MINimum MAXimum DEFault .....	195
[SOURce[1 2]:]SUM:AMPLitude? [MINimum MAXimum] .....	195
[SOURce[1 2]:]SUM:INTernal:FREQUency <frequency> MINimum MAXimum DEFault .....	196
[SOURce[1 2]:]SUM:INTernal:FREQUency? [MINimum MAXimum] .....	196
[SOURce[1 2]:]SUM:INTernal:FUNCTion <function> .....	197
[SOURce[1 2]:]SUM:INTernal:FUNCTion? .....	197
[SOURce[1 2]:]SUM:SOURce INTernal CH1 CH2 .....	198
[SOURce[1 2]:]SUM:SOURce? .....	198
[SOURce[1 2]:]SUM:STATe ON 1 OFF 0 .....	198
[SOURce[1 2]:]SUM:STATe? .....	198
<b>SWEep Subsystem .....</b>	<b>199</b>
[SOURce[1 2]:]SWEep:HTIME <hold_time> MINimum MAXimum DEFault .....	200
[SOURce[1 2]:]SWEep:HTIME? [MINimum MAXimum] .....	200
[SOURce[1 2]:]SWEep:RTIME <return_time> MINimum MAXimum DEFault .....	200
[SOURce[1 2]:]SWEep:RTIME? [MINimum MAXimum] .....	200
[SOURce[1 2]:]SWEep:SPACing LINear LOGarithmic .....	200
[SOURce[1 2]:]SWEep:SPACing? .....	200
[SOURce[1 2]:]SWEep:STATe ON 1 OFF 0 .....	201
[SOURce[1 2]:]SWEep:STATe? .....	201
[SOURce[1 2]:]SWEep:TIME <seconds> MINimum MAXimum DEFault .....	201
[SOURce[1 2]:]SWEep:TIME? [MINimum MAXimum] .....	201
[SOURce[1 2]:]TRACK ON OFF INVerted .....	202
[SOURce[1 2]:]TRACK? .....	202
<b>VOLTage Subsystem .....</b>	<b>203</b>
[SOURce[1 2]:]VOLTage <amplitude> MINimum MAXimum DEFault .....	204
[SOURce[1 2]:]VOLTage? [MINimum MAXimum] .....	204
[SOURce[1 2]:]VOLTage:COUPlE[:STATe] ON 1 OFF 0 .....	205
[SOURce[1 2]:]VOLTage:COUPlE[:STATe]? .....	205
[SOURce[1 2]:]VOLTage:HIGh <voltage> MINimum MAXimum DEFault .....	206
[SOURce[1 2]:]VOLTage:HIGh? [MINimum MAXimum] .....	206
[SOURce[1 2]:]VOLTage:LOW <voltage> MINimum MAXimum DEFault .....	206
[SOURce[1 2]:]VOLTage:LOW? [MINimum MAXimum] .....	206
[SOURce[1 2]:]VOLTage:LIMit:HIGh <voltage> MINimum MAXimum DEFault .....	207
[SOURce[1 2]:]VOLTage:LIMit:HIGh? [MINimum MAXimum] .....	207
[SOURce[1 2]:]VOLTage:LIMit:LOW <voltage> MINimum MAXimum DEFault .....	207
[SOURce[1 2]:]VOLTage:LIMit:LOW? [MINimum MAXimum] .....	207
[SOURce[1 2]:]VOLTage:LIMit:STATe ON 1 OFF 0 .....	208
[SOURce[1 2]:]VOLTage:LIMit:STATe? .....	208
[SOURce[1 2]:]VOLTage:OFFSet <offset> MINimum MAXimum DEFault .....	209
[SOURce[1 2]:]VOLTage:OFFSet? [MINimum MAXimum] .....	209
[SOURce[1 2]:]VOLTage:RANGe:AUTO OFF 0 ON 1 ONCE .....	210

[SOURce[1 2]:]VOLTage:RANGe:AUTO?	210
[SOURce[1 2]:]VOLTage:UNIT VPP VRMS DBM	211
[SOURce[1 2]:]VOLTage:UNIT?	211
<b>STATus Subsystem</b>	<b>212</b>
STATus:OPERation:CONDition?	213
STATus:OPERation:ENABLE <enable_value>	213
STATus:OPERation:ENABLE?	213
STATus:OPERation[:EVENT]?	214
STATus:PRESet	214
STATus:QUESTionable:CONDition?	215
STATus:QUESTionable:ENABLE <enable_value>	216
STATus:QUESTionable:ENABLE?	216
STATus:QUESTionable[:EVENT]?	216
<b>SYSTem Subsystem</b>	<b>217</b>
SYSTem:BEEPer[:IMMediate]	218
SYSTem:BEEPer:STATe ON 1 OFF 0	218
SYSTem:BEEPer:STATe?	218
SYSTem:CLICk:STATeON 1 OFF 0	219
SYSTem:CLICk:STATe?	219
SYSTem:COMMunicate:LAN:CONTRol?	219
SYSTem:COMMunicate:LAN:DHCP ON 1 OFF 0	220
SYSTem:COMMunicate:LAN:DHCP?	220
SYSTem:COMMunicate:LAN:DNS[1   2] "<address>"	221
SYSTem:COMMunicate:LAN:DNS[1   2]? [CURRent STATic]	221
SYSTem:COMMunicate:LAN:DOMain?	221
SYSTem:COMMunicate:LAN:GATEway "<address>"	222
SYSTem:COMMunicate:LAN:GATEway? [CURRent STATic]	222
SYSTem:COMMunicate:LAN:HOSTname "<name>"	223
SYSTem:COMMunicate:LAN:HOSTname? [CURRent STATic]	223
SYSTem:COMMunicate:LAN:IPADdress "<address>"	224
SYSTem:COMMunicate:LAN:IPADdress? [CURRent STATic]	224
SYSTem:COMMunicate:LAN:MAC?	225
SYSTem:COMMunicate:LAN:SMASk "<mask>"	226
SYSTem:COMMunicate:LAN:SMASk? [CURRent STATic]	226
SYSTem:COMMunicate:LAN:TELNet:PROMpt "<string>"	227
SYSTem:COMMunicate:LAN:TELNet:PROMpt?	227
SYSTem:COMMunicate:LAN:TELNet:WMESsage "<string>"	228
SYSTem:COMMunicate:LAN:TELNet:WMESsage?	228
SYSTem:COMMunicate:LAN:UPDate	229
SYSTem:COMMunicate:TCPIP:CONTRol?	229
SYSTem:DATE <yyyy>,<mm>,<dd>	230
SYSTem:DATE?	230
SYSTem:ERRor?	230
SYSTem:SET <block_data>	231
SYSTem:SET?	231
SYSTem:TIME <hh>,<mm>,<ss>	231
SYSTem:TIME?	231
SYSTem:VERSion?	231
<b>TRIGger Subsystem</b>	<b>232</b>
TRIGger[1 2]	233
TRIGger[1 2]:COUNT <number>MINimum MAXimum DEFault	233
TRIGger[1 2]:COUNT? [MINimum MAXimum]	233

---

TRIGger[1 2]:DELay <seconds> MINimum MAXimum DEFault .....	233
TRIGger[1 2]:DELay? [MINimum MAXimum] .....	233
TRIGger[1 2]:SLOPe POSitive NEGative .....	234
TRIGger[1 2]:SLOPe? .....	234
TRIGger[1 2]:SOURce IMMEDIATE EXTernal TIMer BUS .....	235
TRIGger[1 2]:SOURce? .....	235
TRIGger[1 2]:TIMer <seconds> MINimum MAXimum DEFault .....	236
TRIGger[1 2]:TIMer? [MINimum MAXimum] .....	236
<b>UNIT Subsystem</b> .....	<b>237</b>
UNIT:ANGLE DEGree RADian SECond DEFault .....	238
UNIT:ANGLE? .....	238

# Notices

## Copyright Notice

© Keysight Technologies 2020–2022

No part of this manual may be reproduced in any form or by any means (including electronic storage and retrieval or translation into a foreign language) without prior agreement and written consent from Keysight Technologies as governed by United States and international copyright laws.

## Manual Part Number

EDU33212-90013

## Edition

Edition 2, November 2022

## Published by

Keysight Technologies  
Bayan Lepas Free Industrial Zone  
11900 Bayan Lepas, Penang  
Malaysia

## Warranty

THE MATERIAL CONTAINED IN THIS DOCUMENT IS PROVIDED “AS IS,” AND IS SUBJECT TO BEING CHANGED, WITHOUT NOTICE, IN FUTURE EDITIONS. FURTHER, TO THE MAXIMUM EXTENT PERMITTED BY APPLICABLE LAW, KEYSIGHT DISCLAIMS ALL WARRANTIES, EITHER EXPRESS OR IMPLIED, WITH REGARD TO THIS MANUAL AND ANY INFORMATION CONTAINED HEREIN, INCLUDING BUT NOT LIMITED TO THE IMPLIED WARRANTIES OF MERCHANTABILITY AND FITNESS FOR A PARTICULAR PURPOSE. KEYSIGHT SHALL NOT BE LIABLE FOR ERRORS OR FOR INCIDENTAL OR CONSEQUENTIAL DAMAGES IN CONNECTION WITH THE FURNISHING, USE, OR PERFORMANCE OF THIS DOCUMENT OR OF ANY INFORMATION CONTAINED HEREIN. SHOULD KEYSIGHT AND THE USER HAVE A SEPARATE WRITTEN AGREEMENT WITH WARRANTY TERMS COVERING THE MATERIAL IN THIS DOCUMENT THAT CONFLICT WITH THESE TERMS, THE WARRANTY TERMS IN THE SEPARATE AGREEMENT SHALL CONTROL.

## Technology Licenses

The hardware and/or software described in this document are furnished under a license and may be used or copied only in accordance with the terms of such license.

## U.S. Government Rights

The Software is “commercial computer software,” as defined by Federal Acquisition Regulation (“FAR”) 2.101. Pursuant to FAR 12.212 and 27.405-3 and Department of Defense FAR Supplement (“DFARS”) 227.7202, the U.S. government acquires commercial computer software under the same terms by which the software is customarily provided to the public. Accordingly, Keysight provides the Software to U.S. government customers under its standard commercial license, which is embodied in its End User License Agreement (EULA), a copy of which can be found at <http://www.keysight.com/find/sweula>. The license set forth in the EULA represents the exclusive authority by which the U.S. government may use, modify, distribute, or disclose the Software. The EULA and the license set forth therein, does not require or permit, among other things, that Keysight: (1) Furnish technical information related to commercial computer software or commercial computer software documentation that is not customarily provided to the public; or (2) Relinquish to, or otherwise provide, the government rights in excess of these rights customarily provided to the public to use, modify, reproduce, release, perform, display, or disclose commercial computer software or commercial computer software documentation. No additional government requirements beyond those set forth in the EULA shall apply, except to the extent that those terms, rights, or licenses are explicitly required from all providers of commercial computer software pursuant to the FAR and the DFARS and are set forth specifically in writing elsewhere in the EULA. Keysight shall be under no obligation to update, revise or otherwise modify the Software. With respect to any technical data as defined by FAR 2.101, pursuant to FAR 12.211 and 27.404.2 and DFARS 227.7102, the U.S. government acquires no greater than Limited Rights as defined in FAR 27.401 or DFAR 227.7103-5 (c), as applicable in any technical data.

## Third Party Licenses

Portions of this software are licensed by third parties including open source terms and conditions. To the extent such licenses require that Keysight make source code available, we will do so at no cost to you. For more information, please contact Keysight support at <https://www.keysight.com/find/assist>.

## Waste Electrical and Electronic Equipment (WEEE)

This product complies with the WEEE Directive) marketing requirement. The affixed product label (see below) indicates that you must not discard this electrical/electronic product in domestic household waste.

Product Category: With reference to the equipment types in the WEEE directive Annex 1, this product is classified as “Monitoring and Control instrumentation” product. Do not dispose in domestic household waste.

To return unwanted products, contact your local Keysight office, or see [about.keysight.com/en/companyinfo/environment/takeback.shtml](http://about.keysight.com/en/companyinfo/environment/takeback.shtml) for more information.



## Declarations of Conformity

Declarations of Conformity for this product and for other Keysight products may be downloaded from the Web. Go to <http://regulations.corporate.keysight.com/DoC/search.htm> and click on “Declarations of Conformity.” You can then search by product number to find the latest Declaration of Conformity.

## Safety Information

### CAUTION

A CAUTION notice denotes a hazard. It calls attention to an operating procedure, practice, or the like that, if not correctly performed or adhered to, could result in damage to the product or loss of important data. Do not proceed beyond a CAUTION notice until the indicated conditions are fully understood and met.

---

### WARNING

A WARNING notice denotes a hazard. It calls attention to an operating procedure, practice, or the like that, if not correctly performed or adhered to, could result in personal injury or death. Do not proceed beyond a WARNING notice until the indicated conditions are fully understood and met.

---

# 1 Remote Operation

[Introduction to the SCPI Language](#)

[SCPI Error Messages](#)

[Factory Reset State](#)

[Programming Examples](#)

This chapter describes the remote operation for the Keysight EDU33210 Series Trueform Arbitrary Waveform Generator.

## Introduction to the SCPI Language

SCPI (Standard Commands for Programmable Instruments) is an ASCII-based instrument command language designed for test and measurement instruments. SCPI commands are based on a hierarchical structure, also known as a *tree system*. In this system, associated commands are grouped together under a common node or root, thus forming *subsystems*. A portion of the OUTPut subsystem is shown below to illustrate the tree system.

### OUTPut:

**SYNC OFF|0|ON|1**

### **SYNC:**

**MODE NORMAl|CARRier**

**POLarity NORMAl|INVerted**

**OUTPut** is the root keyword, **SYNC** is a second-level keyword, and **MODE** and **POLarity** are third-level keywords. A colon (:) separates a command keyword from a lower-level keyword.

## Syntax Conventions

The format used to show commands is illustrated below:

[SOURce[1|2]:]VOLTage:UNIT VPP|VRMS|DBM

[SOURce[1|2]:]FREQuency:CENTer <frequency>|MINimum|MAXimum|DEFault

The command syntax shows most commands (and some parameters) as a mixture of upper- and lower-case letters. The upper-case letters indicate the abbreviated spelling for the command. For shorter program lines, you can send the abbreviated form. For better program readability, you can send the long form.

For example, in the above syntax statement, VOLT and VOLTAGE are both acceptable forms. You can use upper- or lower-case letters. Therefore, VOLTAGE, volt, and Volt are all acceptable. Other forms, such as VOL and VOLTAG, are not valid and will generate an error.

- A vertical bar (|) separates multiple parameter choices for a given command string. For example, VPP|VR in the above command indicates that you can specify "VPP", "VRMS", or "DBM". The bar is not sent with the command string.
- Triangle brackets in the second example ( < > ) indicate that you must specify a value for the enclosed parameter. For example, the above syntax statement shows the <frequency> parameter enclosed in triangle brackets. The brackets are not sent with the command string. You must specify a value for the parameter (for example "FREQ:CENT 1000") unless you select another option shown in the syntax (for example "FREQ:CENT MIN").
- Braces ({} ) indicate parameters that may be repeated zero or more times. It is used especially for showing arrays. The notation <A>{,<B>} shows that parameter "A" must be entered, while parameter "B" may be omitted or may be entered one or more times



- Some syntax elements (for example nodes and parameters) are enclosed in square brackets ( [ ] ). This indicates that the element is optional and can be omitted. The brackets are not sent with the command string. If you do not specify a value for an optional parameter, the instrument chooses a default value. In the examples above the "SOURce[1|2]" indicates that you may refer to source channel 1 either by "SOURce", or by "SOURce1", or by "SOUR1" or by "SOUR". In addition, since the whole SOURce node is optional (in brackets) you also may refer to channel 1 by entirely leaving out the SOURce node. This is because Channel 1 is the default channel for the SOURce language node. On the other hand, to refer to Channel 2, you must use either "SOURce2" or "SOUR2" in your program lines.

## Command Separators

A colon ( : ) is used to separate a command keyword from a lower-level keyword. You must insert a blank space to separate a parameter from a command keyword. If a command requires more than one parameter, you must separate adjacent parameters using a comma as shown below:

```
APPL:SIN 455E3,1.15,0.0
```

In this example, the APPLy command is specifying a sine wave at a frequency of 455 KHz, with an amplitude of 1.15 volts, and a DC offset of 0.0 volts.

A semicolon ( ; ) is used to separate commands within the same subsystem, and can also minimize typing. For example, sending the following command string:

```
TRIG:SOUR INT; COUNT 10
```

is the same as sending the following two commands:

```
TRIG:SOUR INT
TRIG:COUNT 10
```

## Using the MIN, MAX, and DEF Parameters

For many commands, you can substitute "MIN" or "MAX" in place of a parameter. In some cases you may also substitute "DEF". For example, consider the following command:

```
[SOURce[1|2]:]APPLY:DC [<frequency>|DEF [,<amplitude>|DEF [,<offset>|MIN|MAX|DEF]]]
```

Instead of selecting a specific value for the <offset> parameter, you can substitute MIN to set the offset to its minimum value, MAX to set the offset to its maximum value. You can also specify DEF to set the default value for each parameter: <frequency>, <amplitude>, and <offset>.

## Querying Parameter Settings

You can query the current value of most parameters by adding a question mark ( ? ) to the command. For example, the following command sets the trigger count to 10 readings:

```
TRIG:COUN 10
```

You can then query the count value by sending:

```
TRIG:COUN?
```

You can also query the minimum or maximum count allowed as follows:

```
TRIG:COUN? MIN  
TRIG:COUN? MAX
```

## SCPI Command Terminators

A command string sent to the instrument must terminate with a <new line> (<NL>) character. The IEEE-488 EOI (End-Or-Identify) message is interpreted as a <NL> character and can be used to terminate a command string in place of a <NL> character. A <carriage return> followed by a <NL> is also accepted. Command string termination will always reset the current SCPI command path to the root level.

### NOTE

For every SCPI message that includes a query and is sent to the instrument, the instrument terminates the returned response with a <NL> or line-feed character (EOI). For example, if "DISP:TEXT?" is sent, the response is terminated with a <NL> after the string of data that is returned. If a SCPI message includes multiple queries separated by semicolons (for example "DISP?;DISP:TEXT?"), the returned response is again terminated by a <NL> after the response to the last query. In either case, the program must read this <NL> in the response before another command is sent to the instrument, or an error will occur.

## IEEE-488.2 Common Commands

The IEEE-488.2 standard defines a set of common commands that perform functions such as reset, self-test, and status operations. Common commands always begin with an asterisk (\*), are three characters in length, and may include one or more parameters. The command keyword is separated from the first parameter by a blank space. Use a semicolon (;) to separate multiple commands as shown below:

```
*RST; *CLS; *ESE 32; *OPC?
```

## SCPI Parameter Types

The SCPI language defines several data formats to be used in program messages and response messages.

### Numeric Parameters

Commands that require numeric parameters will accept all commonly used decimal representations of numbers including optional signs, decimal points, and scientific notation. Special values for numeric parameters such as MIN, MAX, and DEF are also accepted. You can also send engineering unit suffixes with numeric parameters (e.g., M, k, m, or u). If a command accepts only certain specific values, the instrument will automatically round the input numeric parameters to the accepted values. The following command requires a numeric parameter for the frequency value:

```
[SOURce[1|2]:]FREQuency:CENTer <frequency>|MINimum|MAXimum
```

**NOTE**

Because the SCPI parser is case-insensitive, there is some confusion over the letter "M" (or "m"). For your convenience, the instrument interprets "mV" (or "MV") as millivolts, but "MHZ" (or "mhz") as megahertz. Likewise "MΩ" (or "mΩ") is interpreted as megohms. You can use the prefix "MA" for mega. For example, "MAV" is interpreted as megavolts.

---

**Discrete Parameters**

Discrete parameters are used to program settings that have a limited number of values (like IMMEDIATE, EXTERNAL, or BUS). They may have a short form and a long form just like command keywords. You can mix upper- and lower-case letters. Query responses will always return the short form in all upper-case letters. The following command requires a discrete parameter for the voltage units:

```
[SOURce[1|2]:]VOLTage:UNIT VPP|VRMS|DBM
```

**Boolean Parameters**

Boolean parameters represent a single binary condition that is either true or false. For a false condition, the instrument will accept "OFF" or "0". For a true condition, the instrument will accept "ON" or "1". When you query a Boolean setting, the instrument will always return "0" or "1". The following command requires a Boolean parameter:

```
DISPlay OFF|0|ON|1
```

**ASCII String Parameters**

String parameters can contain virtually any set of ASCII characters. A string must begin and end with matching quotes; either with a single quote or a double quote. You can include the quote delimiter as part of the string by typing it twice without any characters in between. The following command uses a string parameter:

```
DISPlay:TEXT <quoted string>
```

For example, the following command displays the message "WAITING..." on the instrument's front panel (the quotes are not displayed).

```
DISP:TEXT "WAITING..."
```

You can also display the same message using single quotes.

```
DISP:TEXT 'WAITING...'
```

## Using Device Clear

Device Clear is an IEEE-488 low-level bus message that you can use to return the instrument to a responsive state. Different programming languages and IEEE-488 interface cards provide access to this capability through their own unique commands. The status registers, the error queue, and all configuration states are left unchanged when a Device Clear message is received.

Device Clear performs the following actions:

- If a measurement is in progress, it is aborted.
- The instrument returns to the trigger "idle" state.
- The instrument's input and output buffers are cleared.
- The instrument is prepared to accept a new command string.

### NOTE

The **ABORt** command is the recommended method to terminate an instrument operation.

## Instrument Models

Model	Description
EDU33211A	20 MHz One channel Arbitrary waveforms 8 MSa Memory per channel
EDU33212A	20 MHz Two channels Arbitrary waveforms 8 MSa Memory per channel

## Internal Function Waveforms

The following are the internal function waveforms.

- **SINusoid**: a sine wave, no phase shift.

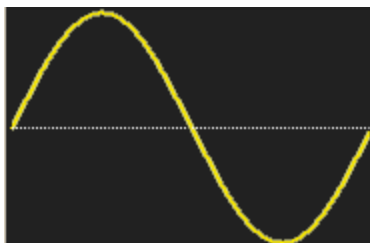

- **SQUare**: a square wave, 50% duty cycle.



- **RAMP**: ramp, 100% symmetry.



- **NRAMP**: negative ramp, 0% symmetry.

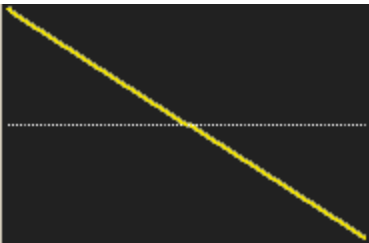

- **TRiangle**: ramp, 50% symmetry.

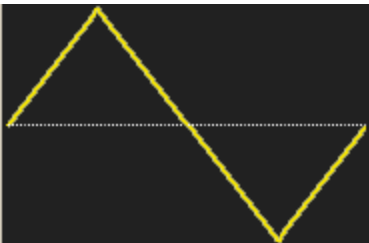

- **NOISe**: gaussian noise; if NOISe is the internal function, it cannot also be the carrier.

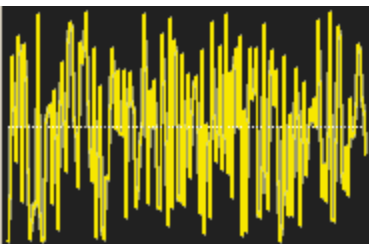

- **PRBS**: pseudo-random binary sequence modulation; if PRBS is the internal function, it cannot also be the carrier.

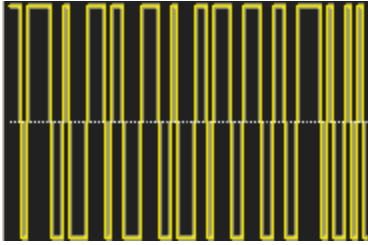

- **ARbitrary**: arbitrary waveform; default is exponential rise; if ARB is the internal function, it cannot also be the carrier.

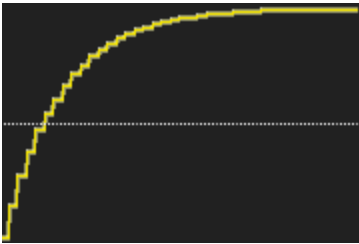

**See Also**

- [AM Subsystem](#)
- [FM Subsystem](#)
- [PM Subsystem](#)
- [PWM Subsystem](#)
- [SUM Subsystem](#)

Maximum Waveform Frequencies by Model

EDU33211A and EDU33212A

Waveform	Maximum Frequency
Sine	20 MHz
Square/Pulse	10 MHz
Noise	20 MHz
Ramp/Triangle	200 kHz
PRBS	50 Mbps
Arbitrary	250 MSa/s

## SCPI Error Messages

The instrument returns error messages in accord with the SCPI standard.

- Up to 20 command syntax or hardware errors can be stored in a single error queue for all interfaces (USB, VXI-11, and Telnet/Sockets).
- The instrument beeps once each time an error is generated (unless disabled by **SYSTem:BEEPer:STATe OFF**). The front panel **ERROR** annunciator turns on when one or more errors are in the error queue.
- A special global error queue holds all power-on and hardware-related errors (for example, overtemperature).
- Error retrieval is first-in-first-out (FIFO), and errors are cleared as you read them. Once you have read all interface-specific errors, the errors in the global error queue are retrieved. When you have read all errors from the global error queue, the **ERROR** annunciator turns off.
- If more than 20 errors have occurred, the last error stored in the queue (the most recent error) is replaced with -350,"Error queue overflow". No additional errors are stored until you remove errors from the queue. If no errors have occurred when you read the error queue, the instrument responds with +0,"No error".
- The front panel reports errors from all I/O sessions and the global error queue. To read the error queue from the front panel, press the **[System]** button, then the **Help** softkey. Then select "View remote command error queue" in the Help menu.
- Error conditions are also summarized in the **Status Byte Register**.
- The interface-specific error queues are cleared by power cycles and **\*CLS**. The error queue is not cleared by **\*RST**.
- **SCPI:**

**SYSTem:ERRor?** *Read and clear one error from the queue.*

Errors have the following format (the error string may contain up to 255 characters):

### NOTE

Most error codes between 600 and 699 refer to self-test errors.

---

Error Code	Error Messages
-100	Command error [generic]
-101	Invalid character
-102	Syntax error [unrecognized command or data type]
-103	Invalid separator
-104	Data type error [e.g., "numeric or string expected, got block data"]
-105	GET not allowed
-108	Parameter not allowed [too many parameters]
-109	Missing parameter [too few parameters]
-112	Program mnemonic too long [maximum 12 characters]
-113	Undefined header [operation not allowed for this device]
-114	Header suffix out of range
-115	Invalid parameter; Parameter not supported on one channel instrument
-121	Invalid character in number [includes "9" in octal data, etc.]
-123	Numeric overflow [exponent too large; exponent magnitude >32 k]
-124	Too many digits [number too long; more than 255 digits received]
-203	Command protected; Enter calibration password from front panel calibration menu
-213	INIT ignored



50V input range not compatible with 50 ohm input impedance; impedance set to 1 Mohm  
AM depth forced amplitude change  
AM turned off by selection of other mode or modulation  
amplitude changed due to function  
amplitude changed due to offset  
amplitude units changed to Vpp due to high-Z load  
amplitude units changed to Vpp, dBm and Vrms not applicable to arb sequences  
amplitude units unchanged, dBm and Vrms not applicable to arb sequences  
arb advance changed to SRATE due to filter  
arb advance changed to SRATE due to mode  
arb voltage reduced due to output load or limits  
Balance gain limited due to amplitude.  
Balance offset changed due to amplitude  
both edge times decreased due to period  
both edge times decreased due to pulse duty cycle  
both edge times decreased due to pulse width  
BPSK turned off by selection of other mode or modulation  
burst count reduced to fit entire burst  
Burst mode has caused output phase to be set to zero degree  
burst period increased to fit entire burst  
burst phase inapplicable for arbs larger than 1M. burst phase set to 0  
burst turned off by selection of other mode or modulation  
Cannot combine DC function  
cannot delete state selected and enabled for automatic power-on recall  
Cannot modulate ARB carrier with ARB as modulation function. Modulation turned off.  
Cannot modulate ARB carrier with ARB modulation function. Function unchanged.  
Cannot modulate ARB carrier with USER as modulation function. Modulation turned off.  
Cannot modulate ARB carrier with USER modulation function. Function unchanged.  
Cannot modulate by a two-channel Arb  
Cannot modulate Noise carrier with Noise as modulation function. Modulation turned off.  
Cannot modulate Noise carrier with Noise modulation function. Function unchanged.  
Cannot modulate PRBS carrier with PRBS as modulation function. Modulation turned off.  
Cannot modulate PRBS carrier with PRBS modulation function. Function unchanged.  
Cannot modulate USER carrier with ARB as modulation function. Modulation turned off.  
Cannot modulate USER carrier with ARB modulation function. Function unchanged.  
Cannot modulate USER carrier with USER as modulation function. Modulation turned off.  
Cannot modulate USER carrier with USER modulation function. Function unchanged.  
Cannot select channel as modulating source  
Cannot use filter in advance arb trigger mode.  
combine amplitude exceeds limit. Combine disabled  
Combine turned off by selection of DC function  
coupling cannot be ON with this function, coupling turned off  
coupling violates settings, coupling turned off

---

edge time decreased due to bit rate  
external gating not compatible with gate output; gate output disabled  
FM deviation cannot exceed carrier  
FM deviation exceeds maximum frequency  
FM turned off by selection of other mode or modulation  
frequency changed for pulse function  
frequency changed for sine function  
frequency changed for square function  
frequency forced duty cycle change  
frequency made compatible with burst mode  
frequency reduced for ramp function  
frequency reduced for user function  
FSK turned off by selection of other mode or modulation  
Function or modulation source cannot be USER. Tracking disabled  
Function selection limited the FSK frequency.  
Gated output not available for gated burst. Output mode changed to normal.  
high level changed due to low level  
high limit less than low limit. Limits disabled  
infinite burst changed trigger source to BUS  
input threshold voltage > input range; threshold clipped to range  
leading edge time decreased due to period  
leading edge time decreased due to pulse width  
leading edge times decreased due to pulse duty cycle  
limited frequency to 1MHz when sync mode carrier, burst ON, and function sine  
list turned off by selection of other mode or modulation  
low level changed due to high level  
low reference >= high reference  
marker forced into sweep span  
marker off forced sync to normal mode  
marker on forced sync to marker mode  
marker point changed to fit arb length  
modulation frequency made compatible with modulation shape  
must stop operation to update trigger count  
must stop operation to update trigger delay  
not able to adjust phase in this function  
not able to adjust phase in this mode  
not able to burst DC, burst turned off  
not able to burst this function  
not able to change output load with limits enabled  
not able to list arb, list turned off  
not able to list DC, list turned off  
not able to list noise, list turned off  
not able to list PRBS, list turned off  
not able to list this function  
not able to modulate arb, modulation turned off  
not able to modulate DC, modulation turned off  
not able to modulate noise, modulation turned off

---

not able to modulate PRBS, modulation turned off  
not able to modulate this function  
not able to sweep arb, sweep turned off  
not able to sweep DC, sweep turned off  
not able to sweep noise, sweep turned off  
not able to sweep PRBS, sweep turned off  
not able to sweep this function  
offset changed due to amplitude  
offset changed on exit from DC function  
PM turned off by selection of other mode or modulation  
pulse duty cycle decreased due to period  
pulse duty cycle increased due to period  
pulse width decreased due to period  
pulse width increased due to large period  
PWM deviation decreased due to pulse parameters  
PWM only available in pulse function  
PWM turned off by selection of other mode or modulation  
selected arb is missing, changing selection to default  
selecting a sequence turned off modulation  
sequences not supported, changing selection to default  
signal exceeds high limit. Limits disabled  
signal exceeds low limit. Limits disabled  
sum amplitude exceeds limit or range. Sum disabled  
SUM turned off by selection of other mode or modulation  
Sweep + Hold + Return time larger than trigger TIMER. Trig timer increased.  
Sweep + Hold + Return time max (8000s) limited time setting.  
Sweep + Hold + Return time max (8000s) limited time setting.  
Sweep + Hold + Return time too large for IMM or TIMER trigger. Sweep turned off.  
Sweep + Hold + Return time too large for IMM or TIMER trigger. Trig source unchanged.  
Sweep time reduced due to log sweep setting.  
sweep turned off by selection of other mode or modulation  
Tracking turned off by selection of USER function or modulation source  
trailing edge decreased due to leading edge  
trailing edge time decreased due to period  
trailing edge time decreased due to pulse width  
trailing edge times decreased due to pulse duty cycle  
trigger delay reduced to fit entire burst  
trigger output connector used by BPSK  
trigger output connector used by burst gate  
trigger output connector used by FSK  
trigger output connector used by trigger external  
trigger output disabled  
trigger output disabled by trigger external  
Trigger source limited the sweep time; value clipped to upper limit  
triggered burst not available for noise  
turned off infinite burst to allow immediate trigger source  
Use FUNC:ARB to select an ARB before selecting ARB as modulation function. Function unchanged.  
Use FUNC:ARB to select an ARB before selecting ARB as modulation function. Modulation disabled.

---

---

-222 Data out of range;

- AM depth
- amplitude
- arb frequency
- arb period
- burst count
- burst count
- limited by length of burst
- burst period
- burst period limited by length of burst
- cannot combine channel with itself. Combine disabled
- duty cycle
- duty cycle limited by frequency
- FM deviation
- FM deviation limited by maximum frequency
- FM deviation limited by minimum frequency
- frequency
- frequency in burst mode
- frequency in FM
- high level limited by high soft limit
- high level limited by low level
- high level limited by low soft limit
- high limit value limited by high signal level
- large period limits minimum pulse width
- low level limited by high level
- low level limited by high soft limit
- low level limited by low soft limit
- low limit value limited by low signal level
- marker confined to burst cycles
- marker confined to sweep span
- offset
- period
- PRBS edge time
- PRBS edge time limited by bit rate
- pulse duty cycle limited by period
- pulse edge at maximum
- pulse edge at minimum
- pulse edge time
- pulse edge time limited by duty cycle
- pulse edge time limited by period
- pulse edge time limited by width
- pulse frequency
- pulse period
- pulse width
- pulse width limited by period
- PWM deviation
- PWM deviation limited by pulse parameters

---

ramp frequency  
 ramp Symmetry  
 Sample rate  
 sample rate clipped to lower limit  
 sample rate clipped to upper limit  
 square edge time  
 square edge time limited by duty cycle  
 square edge time limited by period  
 square edge time limited by width  
 square period square width  
 sum amplitude limited by channel or combine amplitudes  
 sum amplitude value clipped to lower limit  
 sweep time  
 Track exceeds limits on channel 1. Tracking disabled  
 Track exceeds limits on channel 2. Tracking disabled  
 trigger count clipped to lower limit  
 trigger count clipped to upper limit  
 trigger delay  
 trigger delay clipped to lower limit  
 trigger delay clipped to upper limit  
 trigger delay limited by length of burst  
 trigger level clipped to lower limit  
 trigger level clipped to upper limit  
 trigger timer clipped to lower limit  
 trigger timer clipped to upper limit  
 trigger timer limited by length of burst  
 user frequency  
 USER setting only valid for channel 1  
 value clipped to dwell time's lower limit  
 value clipped to dwell time's upper limit  
 value clipped to lower limit  
 value clipped to sweep time's lower limit  
 value clipped to upper limit  
 value limited due to coupling

---

-222	List Data out of range; Arb frequency : Mode is changed to Normal
-222	List Data out of range; Pulse frequency : Mode is changed to Normal
-222	List Data out of range; Ramp frequency : Mode is changed to Normal
-222	List Data out of range; Sine frequency : Mode is changed to Normal
-222	List Data out of range; Square frequency : Mode is changed to Normal
-222	List Data out of range; User frequency : Mode is changed to Normal
-222	Setting the advance mode to trigger forced the trigger source to external.
-222	Setting the Arb Filter OFF changed the maximum sample rate value to 6.25e7.
-222	Setting the trigger source changed the arb advance mode.
-230	Data corrupt or stale
-241	Hardware missing

---

-241	Hardware missing; Command not valid in one channel instrument.
-250	Mass storage error: file read/write error
-252	Missing media
-254	Media full
-256	File or folder name not found
-257	File name error; access denied drive name missing or not recognized file or folder already exists file too large folder is default folder folder not empty invalid character in name not a folder name path is a folder name path name missing path too long relative path not allowed unknown file extension
-292	Referenced name does not exist
-310	System error; internal software error
-310	System error; out of memory
-310	System error; software initialization failed
-313	Calibration memory lost
-313	Calibration memory lost; due to firmware revision change
-313	Cannot read file; due to corrupt data
-313	Cannot read file; due to file revision change
-313	Invalid number of channels for operation
-314	Save/recall memory lost; due to firmware revision change
-314	Save/recall memory lost; memory corruption detected
-315	Configuration memory lost; due to firmware revision change
-315	Configuration memory lost; memory corruption detected
100	Network Error
110	LXI mDNS Error
201	Memory lost: stored state
202	Memory lost: power-on state
203	Memory lost: stored measurements
263	Not able to execute while instrument is measuring
291	Not able to recall state: it is empty
292	State file size error

293	State file corrupt
301	Cannot reset input protection; high voltage present
305	Not able to perform requested operation
500	3.3V power lost
501	5.0V power lost
502	12V power lost
505	EEPROM load failed
506	EEPROM checksum failed
507	EEPROM save failed
510	LAN invalid subnet mask or gateway
511	LAN invalid DNS address 1
512	LAN invalid DNS address 2
513	LAN invalid IP address
514	LAN duplicate IP address
515	LAN failed to renew DHCP lease
516	LAN failed to configure
517	LAN failed to initialize
518	LAN VXI-11 fault
521	Communications: input buffer overflow
522	Communications: output buffer overflow
532	Not able to achieve requested resolution
540	Cannot use overload as math reference
550	Not able to execute command in local mode
560	No valid external timebase
561	High voltage present on input channel
570	DDS Processor is not responding
580	Reference phase-locked loop is unlocked
600	Internal licensing error
601	License file corrupt or empty
602	No valid licenses found for this instrument
603	Some licenses could not be installed
604	License not found
605	License already installed
701	Calibration error; security defeated by hardware jumper
702	Calibration error; security defeated by hardware jumper
703	Calibration error; secure code provided was invalid
704	Calibration error: secure code too long

705	Calibration error; calibration aborted
706	Calibration error; provided value is out of range
707	Calibration error: computed correction factor out of range
707	Calibration error; signal input is out of range
708	Calibration error: signal measurement out of range
709	Calibration error: no calibration for this function/range
710	Calibration error: full scale correction out of range
710	Self-calibration failed
711	Calibration error: calibration string too long
711	Self-calibration failed
712	Calibration failed
712	Self-calibration failed
715	Self-calibration failed
720	Self-calibration failed
740	Calibration data lost: secure state
741	Calibration data lost: string data
742	Calibration data lost: corrections
748	Calibration memory write failure
770	Nonvolatile arb waveform memory corruption detected
781	Not enough memory to store new arb waveform; bad sectors
781	Not enough memory to store new arb waveform; use DATA:DELETE
782	Cannot overwrite a built-in arb waveform
784	Name of source arb waveform for copy must be VOLATILE
785	Specified arb waveform does not exist
786	Not able to delete a built-in arb waveform
786	Specified arb waveform already exists
787	Not able to delete the currently selected active arb waveform
787	Specified arb not loaded in waveform memory
788	Could not load specified arb; Loaded Built-in default arb
791	Firmware update error; unable to begin download
792	Firmware update error; programming operation failed
793	Firmware update error; data record invalid character
794	Firmware update error; data record length mismatch
795	Firmware update error; data record checksum mismatch
796	Firmware update error; bad checksum for download start
797	Firmware update error; bad checksum for download complete
798	Firmware update error; download in progress



799	Firmware update error; unable to complete download
800	Firmware update error; invalid programming address
810	State has not been stored
850	Calibration error; set up is invalid
851	Calibration error; set up is out of order
870	Arb: Text File Format error; invalid format
871	Arb: Segment name is too long
872	Arb: File name is too long
873	Arb: Too many sequence steps
874	Arb: Too many segments defined
875	Arb: Too many sequences defined
876	Arb: Sequence already defined
877	Arb: Segment not found
878	Arb: Sequence not found
879	Arb: Segment edit too large
880	Arb: Out of memory
881	Arb: Channel count mismatch
881	Arb: Values are out of range
882	Arb: Segment too small
883	Arb: Error in closing file
884	Arb: Seek too large
885	Arb: Arb file cannot be stored as sequence file
886	Arb: Sequence file cannot be stored as arb file
887	File name error; not a valid extension
888	Arb: Could not create built in arb directory
889	Arb: Could not copy built in arb
890	enable combine forced tracking off
891	enable coupling forced tracking off
892	enable tracking forced coupling off
893	enable tracking forced combine off
900	Firmware update failed

## Factory Reset State

The following tables show factory default settings. Parameters marked with a bullet (•) are non-volatile, and are not affected by power cycling or \*RST. Other parameters are volatile and reset to the indicated values at power-on or after \*RST.

### NOTE

The power-on/reset state may differ from that shown below if you have enabled power-on state recall mode from the **[System]** menu. Refer to "Store or Retrieve the Instrument State" in the User's Guide.

Parameter	Factory Settings
<b>Output Channel Configuration</b>	
Function	Sine
Tracking	Off
Frequency	1 kHz
Frequency Mode	CW
Frequency Couple State	OFF
Frequency Couple Mode	Ratio
Frequency Couple Ratio	1
Frequency Couple Offset	0
Amplitude	100 mVpp
Offset	0 VDC
Voltage Couple State	OFF
Voltage Limit State	OFF
Voltage Limit High	5 V
Voltage Limit Low	-5 V
Voltage Unit	VPP
Voltage Range	AUTO
State	OFF
Load	50 $\Omega$
Polarity	Normal
Mode (Normal vs. Gated)	Normal
Sync Polarity	Normal
Sync Mode	Normal
Sync State	ON
Sync Source	CH1
Trigger Source	CH1
Trigger Slope	Positive
Trigger State	OFF

Parameter	Factory Settings
<b>Noise</b>	
Bandwidth	100 kHz
<b>PRBS</b>	
Data	PN7
Bit Rate	1 kbps
Transition	8.4E-09
<b>Pulse</b>	
Duty Cycle	10%
Period	1 ms
Leading/Trailing Edge	10 ns
Width	0.1 ms
<b>Ramp</b>	
Symmetry	100
<b>Square</b>	
Duty Cycle	50%
Period	1 ms
<b>Arbitrary Waveforms</b>	
Arb	Exponential Rise
Filter	STEP
Sample Rate	40 kSa/sec
Advance	SRATE
Marker Point	Mid point of arb
<b>Amplitude Modulation</b>	
State	OFF
Modulation Source	Internal
Internal Function	Sine
Internal Frequency	100 Hz
Depth	100%
DSSC	OFF
<b>Frequency Modulation</b>	
State	OFF
Modulation Source	Internal
Internal Function	Sine
Internal Frequency	10 Hz
Deviation	100 Hz

Parameter	Factory Settings
<b>FSK Modulation</b>	
State	OFF
Internal Function	Sine
Internal Rate	10 Hz
Frequency	100 Hz
<b>Phase Modulation</b>	
State	OFF
Modulation Source	Internal
Function	Sine
Frequency	10 Hz
Deviation	180 degrees
<b>BPSK Modulation</b>	
State	OFF
Modulation Source	Internal
Internal Rate	10 Hz
Phase	180 degrees
<b>Pulse Width Modulation</b>	
State	OFF
Modulation Source	Internal
Function	Sine
Frequency	10 Hz
Deviation	1% or 1E-5 sec, depending on how specified
<b>SUM</b>	
State	OFF
Source	Internal
Function	Sine
Frequency	100 Hz
Sum Amplitude	0.10%
<b>Phase Control</b>	
Phase Adjust	0 degrees
Unlock Error State	OFF
Units	degrees
<b>Burst</b>	
State	OFF
Gate Polarity	Normal

Parameter	Factory Settings
Mode	Triggered
Cycles	1
Period	10 ms
Phase	0 degrees
Marker Cycle	2
<b>Sweep</b>	
State	OFF
Spacing	Linear
Start Freq	100 Hz
Stop Freq	1 kHz
Center Freq	550 Hz
Span	900 Hz
Marker Freq	500 Hz
Sweep Time	1 sec
Hold Time	0 sec
Return Time	0 sec
<b>List</b>	
Frequency	100, 1000, 550 Hz
Points	3
Dwell	1 sec
<b>Trigger</b>	
Delay	0 sec
Slope	Positive
Source	Immediate
Timer	1 sec
Init Continuous	ON
Count	1
<b>Channel Independent Trigger Configuration</b>	
Init Continuous All	ON
<b>Miscellaneous</b>	
Format Byte Order	Normal
Combine Feed	NONE

The following items do not relate to channel configuration.

#### Display

Parameter	Factory Settings
State	ON
Hcopy Format	BMP
Remote Interface Communication	
DHCP	Enabled
IP Address static	192.168.10.1
Subnet Mask static	255.255.255.0
Gateway static	192.168.10.1
DNS primary server	0.0.0.0
DNS secondary server	0.0.0.0
Hostname static	"K-33xxxx-nnnnn", where xxxx is the last four digits of the model number, and nnnnn is the last 5 digits of the instrument's serial number
Telnet Prompt	EDU33xxxx >, where xxxx is the last four digits of the model number.
Telnet Welcome Message	Welcome to Keysight's EDU33xxxx Arbitrary Waveform Generator, where xxxx is the last four digits of the model number.
System	
Beep State	ON
Power Down Recall	OFF
LXI	
Identify	OFF
Calibration	
Calibration State	Secured

**NOTE**

The instrument uses LAN port 5024 for SCPI Telnet sessions, and port 5025 for SCPI Socket sessions.

## SCPI Status Registers

All SCPI instruments implement status registers in the same way. The status system records various instrument conditions in four register groups: the Status Byte register, the Standard Event register, the Standard Operation register, and the Questionable Data register groups. The Status Byte register records high-level summary information reported in the other register groups.

The figure below illustrates the SCPI status system used by the instrument.

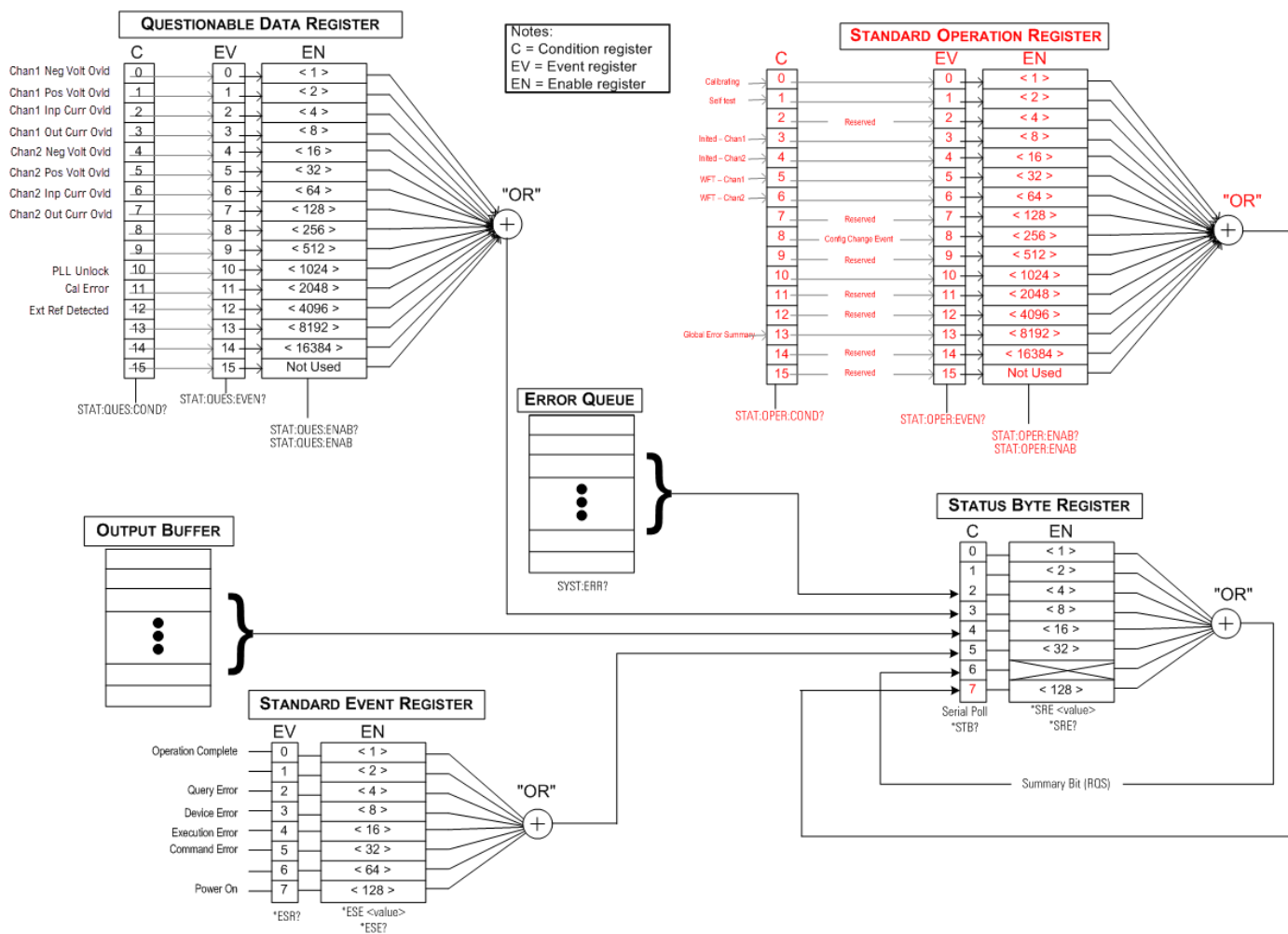

## What is an event register?

An event register is a read-only register that reports defined conditions within the instrument. Bits in an event register are latched. Once an event bit is set, subsequent state changes are ignored. Bits in an event register are automatically cleared by a query of that register (such as \*ESR? or STAT:QUES:EVEN?) or by sending the \*CLS (clear status) command. A reset (\*RST) or device clear will not clear bits in event registers. Querying an event register returns a decimal value of the binary-weighted sum of all bits set in the register.

## What is a condition register?

A condition register continuously monitors the state of the instrument. The bits in the condition register are updated in real time and the bits are not latched or buffered.

## What is an enable register?

An enable register defines which bits in the corresponding event register are logically ORed together to form a single summary bit. Enable registers are both readable and writable. Querying an enable register will not clear it. The \*CLS (clear status) command does not clear enable registers but it does clear the bits in the event registers. To enable bits in an enable register, you must write a decimal value which corresponds to the binary-weighted sum of the bits you wish to enable in the register.

## The Questionable Data register

The following table lists the bit definitions for the Questionable Data register:

Bit	Bit Name	Decimal Value	Definition
0	Channel 1 Negative Voltage Overload	1	Negative voltage overload on channel 1 output connector. The output has been disabled.
1	Channel 1 Positive Voltage Overload	2	Positive voltage overload on channel 1 output connector. The output has been disabled.
2	Channel 1 Input Current Overload	4	Input current overload on channel 1 output connector. The output has been disabled.
3	Channel 1 Output Current Overload	8	Output current overload on channel 1 output connector. The output has been disabled.
4	Channel 2 Negative Voltage Overload	16	Negative voltage overload on channel 2 output connector. The output has been disabled.
5	Channel 2 Positive Voltage Overload	32	Positive voltage overload on channel 2 output connector. The output has been disabled.
6	Channel 2 Input Current Overload	64	Input current overload on channel 2 output connector. The output has been disabled.
7	Channel 2 Output Current Overload	128	Output current overload on channel 2 output connector. The output has been disabled.
8	(Reserved)	256	(Reserved for future use)
9	(Reserved)	512	(Reserved for future use)
10	Loop Unlocked	1024	Function generator has lost phase lock. Frequency accuracy will be affected.
11	Calibration Error	2048	Error occurred during calibration, calibration is unsecured, or calibration memory has been lost
12	External Reference	4096	External timebase has been detected.
13-15	(Reserved)	4096 - 32,768	(Reserved for future use)



## The Standard Operation register

The following table lists the bit definitions for the Standard Operation register:

Bit	Bit Name	Decimal Value	Definition
0	Calibrating	1	The instrument is performing a calibration.
1	Self-test	2	A self-test is running.
2	(Reserved)	4	(Reserved for future use)
3	Channel 1 Initiated	8	Channel is initiated and outputting the desired waveform. In INIT[1 2]:CONT OFF, this bit is set after receiving an INIT and not cleared until channel goes to IDLE ( trigger count satisfied and not busy.) This bit is 0 if the channel is in INIT[1 2]:CONT ON mode.
4	Channel 2 Initiated	16	4
5	Waiting for Trigger, Channel 1	32	Instrument is waiting for a trigger. In INIT[1 2]:CONT OFF, this bit is set after receiving an INIT and while waiting for a trigger. It is cleared after receiving the trigger. This bit is 0 if the channel is in INIT[1 2]:CONT ON mode.
6	Waiting for Trigger, Channel 2	64	6
7	(Reserved)	128	(Reserved for future use)
8	Configuration Changed Event	256	This bit is always 0 in the condition register, as it reflects an event, not a condition.
9	(Reserved)	512	(Reserved for future use)
10	(Reserved for future use)	1024	(Reserved for future use)
11	(Reserved)	2048	(Reserved for future use)
12	(Reserved)	4096	(Reserved for future use)
13	Global Error	8192	This is set if any remote interface has an error in its error queue, and cleared otherwise.
14-15	(Reserved)	16,384 - 32,768	(Reserved for future use)

## The Standard Event register

The following table lists the bit definitions for the Standard Event register:

Bit	Bit Name	Decimal Value	Definition
0	Operation Complete	1	All commands before and including *OPC have been executed.
1	(not used)	2	(Reserved for future use)
2	Query Error	4	The instrument tried to read the output buffer but it was empty. Or, a new command line was received before a previous query has been read. Or, both the input and output buffers are full.
3	Device-Specific Error	8	A device-specific error, including a self-test error, calibration error or other device-specific error occurred. See <b>Error Messages</b> .
4	Execution Error	16	An execution error occurred. See <b>Error Messages</b> .

Bit	Bit Name	Decimal Value	Definition
5	Command	32	A command syntax error occurred. See <b>Error Messages</b> .
6	(not used)	64	(Reserved for future use)
7	Power On	128	Power has been cycled since the last time the event register was read or cleared.

## The Status Byte register

This register summarizes the information from all other status groups as defined in the IEEE 488.2 Standard Digital Interface for Programmable Instrumentation.

The following table lists the bit definitions for the Status Byte register:

Bit	Bit Name	Decimal Value	Definition
0	(not used)	1	(Reserved for future use)
1	(not used)	2	(Reserved for future use)
2	Error Queue	4	One or more errors in the Error Queue. Use <b>SYSTem:ERRor?</b> to read and delete errors.
3	Questionable Data Summary	8	One or more bits are set in the Questionable Data Register (bits must be enabled, see <b>STATus:QUEStionable:ENABLE</b> ).
4	Message Available	16	Data is available in the instrument's output buffer.
5	Standard Event Summary	32	One or more bits are set in the Standard Event Register (bits must be enabled, see <b>*ESE</b> ).
6	Master Summary	64	One or more bits are set in the Status Byte Register and may generate a Request for Service (RQS). Bits must be enabled using <b>*SRE</b> .
7	Operation Register	128	One or more bits are set in the Operation Status Register. Bits are enabled using <b>STATus:OPERation:ENABLE</b> .

## Programming Examples

These programming examples help you get started with common tasks.

- [Configure a Sine Wave](#)
- [Configure a Square Wave](#)
- [Configure a Ramp Wave](#)
- [Configure a Pulse Wave](#)
- [Create a List of Frequencies](#)
- [Configure an Arbitrary Waveform](#)

## Configure a Sine Wave

This section describes the configuration of a sine wave function.

### Description

A sine wave has amplitude, offset, and phase relative to sync pulse. Its amplitude and offset can also be set using high and low voltage values.

### Example

The following waveform can be set up with the series of SCPI commands, where high and low can be used in place of **SOUR:VOLT** and **SOUR:VOLT:OFFS**.

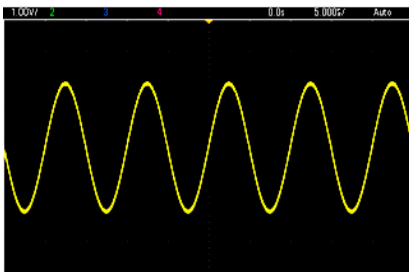

The following commands produce the sine wave shown above.

```
FUNCTION SIN
FREQUENCY +1.0E+05
VOLTage:HIGH +2.0
VOLTage:LOW +0.0
OUTPut ON
PHASe +90.0
```

### Remarks

- Although period can be adjusted from the front panel, there is no **SOUR:FUNC:SIN:PER** or **SOUR:PER** command that can be used in addition to **SOUR:FREQ**.

## Configure a Square Wave

### Description

A square wave has amplitude, offset, and phase relative to sync pulse. It also has duty cycle and period. Its amplitude and offset can also be set using high and low voltage values.

### Example

The following waveform can be set up with the series of SCPI commands, where high and low can be used in place of **SOUR:VOLT** and **SOUR:VOLT:OFFS**.

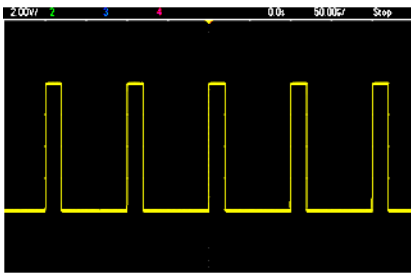

The following commands produce the square wave shown above.

```
FUNC SQU
FUNC:SQU:DCYC +20.0
FREQ +1.0E+04
VOLT:HIGH +4.0
VOLT:LOW +0.0
OUTP 1
```

### Remarks

- For Square Wave, if you change **SOUR:FREQ**, the **SOUR:FUNC:SQU:PER** will change. For example, SOUR:FREQ +2.0E+03 is equivalent to SOUR:FUNC:SQU:PER +5.0E-04.

Configure a Ramp Wave

### Description

A ramp wave has amplitude, offset, and phase relative to sync pulse. It also has symmetry for creating triangular and other similar waveforms. Its amplitude and offset can also be set using high and low voltage values.

### Example

The following waveform can be set up with the series of SCPI commands, where high and low can be used in place of **SOUR:VOLT** and **SOUR:VOLT:OFFS**.

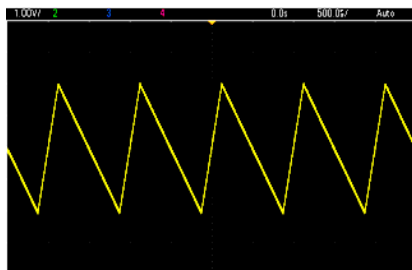

The following commands produce the ramp wave shown above.

```
FUNCTION RAMP
FUNCTION:RAMP:SYMMetry 25
FREQ +1.0E+03
VOLTage +2.0
VOLTage:OFFSet +1.0
OUTP 1
```

## Remarks

- Ramp frequency is limited to 200 kHz.
- Although period can be adjusted from the instrument's front panel, there is no SOUR:FUNC:RAMP:PER or SOUR:PER command that can be used in addition to **SOUR:FREQ**.

## Configure a Pulse Wave

### Description

A pulse wave has amplitude, offset, and phase relative to sync pulse. It also adds edge slope, period, and duty cycle (or pulse width, depending on the **FUNC:PULSe:HOLD** configuration). Its amplitude and offset can also be set using high and low voltage values.

### Example

The following waveform can be set up with the series of SCPI commands, where high and low can be used in place of **SOUR:VOLT** and **SOUR:VOLT:OFFS**.

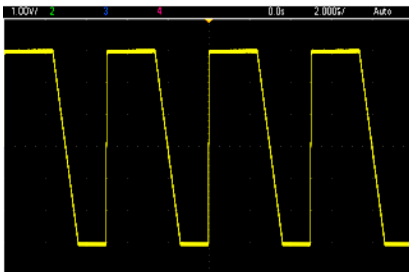

The following commands produce the pulse wave shown above.

```
FUNC PULS
FUNC:PULS:TRAN:LEAD 4E-8
FUNC:PULS:TRAN:TRA 1E-6
FUNC:PULS:WIDT 3E-6
FREQ 2E5
VOLT 3
OUTP ON
```

## Remarks

- You can use **FUNC:PULS:PER** instead of **FREQ**. These commands are paired; changing one changes the other.
- Pulse can be specified by width or duty cycle, which are also coupled. Use **FUNCTION:PULSe:HOLD DCYC** to specify that duty cycle is held constant value as frequency or period changes. Use **FUNCTION:PULSe:HOLD WIDTH** to specify that pulse width is held constant as frequency or period changes.

## Create a List of Frequencies

### Description

The **LIST** commands set the instrument's output frequency according to entries in a frequency list, which allows fast changing to frequencies in a list of up to 128 frequencies. The frequencies to be used are entered using the **LIST:FREQUENCY** command, or they may be read from a file using **MMEMory:LOAD:LIST[1|2]**.

### Examples

The following code demonstrates the **LIST:FREQUENCY** method.

```
FUNCTION SQU
TRIGGER:SOURCE IMMEDIATE
FREQUENCY:MODE LIST
LIST:DWELL +5.0E-03
LIST:FREQUENCY +1.0E+03,+3.0E+03,+7.0E+03
VOLTAGE +1.0
OUTPUT 1
```

The results of this code are shown below.

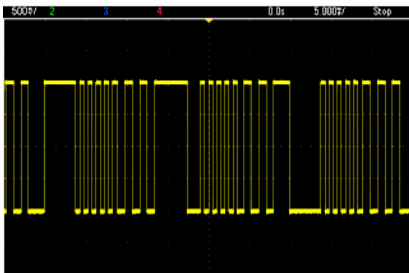

## Configure an arbitrary waveform

This section describes the configuration of an arbitrary waveform.

### Description

A user-created arbitrary waveform has amplitude, offset, sample rate, and filter type. These can be set when the arbitrary waveform file (.arb extension) is loaded into waveform memory. The beginning of a typical arbitrary waveform is shown below; note that amplitude and offset are represented by high and low voltage values:

```
File Format:1.10
Checksum:0
Channel Count:1
Sample Rate:20000.000000
High Level:2.000000
Low Level:0.000000
Marker Point:50
Data Type:"short"
Filter:"off"
Data Points:100
```



```
Data:
23259
23114
```

The **23259** and **23114** lines after the **Data:** line are ASCII DAC codes representing the first two waveform data values. If the waveform's DAC codes do not range from -32767 to + 32767, the output amplitude is asymmetric.

Built-in waveforms make few or no changes when loaded into waveform memory. They play according to the instrument's current configuration. For example, see the beginning of Haversine.arb, shown below.

```
Copyright: Keysight Technologies, 2010
File Format:1.0
Channel Count:1
Data Points:40
Data:
0
202
802
```

Because of the missing metadata, the current settings for voltage range, sample rate, and filter setup are used.

## Examples

The following code loads and modifies a built-in arbitrary waveform.

```
FUNCTION ARB
VOLTage +3
VOLTage:OFFSet +1
FUNC:ARB:SRAT 1E5
FUNCTION:ARbitrary "INT:\BUILTIN\EXP_RISE.ARB"
OUTPut 1
```

The waveform resulting from these commands is shown below.

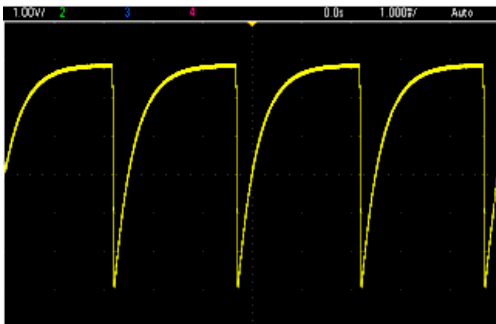

# 2 SCPI Programming

ABORt Subsystem  
AM Subsystem  
APPLy Subsystem  
BPSK Subsystem  
BURSt Subsystem  
CALibration Subsystem  
COMBine:FEED  
DATA Subsystem  
DISPlay Subsystem  
FM Subsystem  
FORMat Subsystem  
FREQuency Subsystem  
FSKey Subsystem  
FUNction Subsystem  
HCOPy Subsystem  
IEEE-488 Common Commands  
INITiate Subsystem  
LIST Subsystem  
LXI Subsystem  
MARKer Subsystem  
MEMory Subsystem  
MMEMory Subsystem  
OUTPut Subsystem  
PHASe Subsystem  
PM Subsystem  
PWM Subsystem  
RATE Subsystem  
SOURce Subsystem  
STATus Subsystem  
SUM Subsystem  
SWEep Subsystem  
SYSTEM Subsystem  
TRACK  
TRIGger Subsystem  
UNIT Subsystem  
VOLTAGE Subsystem

This chapter describes the subsystem commands available to the Keysight EDU33210 Series Trueform Arbitrary Waveform Generator

## ABORt Subsystem

### Command Summary

- **ABORt**

## ABORt

Halts a list, sweep, or burst, even an infinite burst. Also causes trigger subsystem to return to idle state. If **INITiate:CONTinuous** is ON, instrument immediately proceeds to wait-for-trigger state.

Parameter	Typical Return
(none)	(none)
Halt the items listed above: <b>ABORt</b>	

### Remarks

- Halts any triggered action (triggered list, triggered sweep, triggered burst, triggered arbitrary waveform playback).
- ABORt has no effect when instrument is in normal or modulated modes, except for lists, bursts, and sweeps. If instrument is running a list, burst, or sweep, ABORt restarts the stopped item with the current **INIT** and trigger conditions.
- When ABORt occurs in list mode, the frequency goes back to the "normal" mode frequency until the first trigger occurs. After the first trigger, the first frequency in the list will be used.
- If ABORt executed during sweep, sweep returns to starting sweep frequency.
- ABORt always applies to both channels in a two-channel instrument.

## CALibration Subsystem

The CALibration subsystem is used to calibrate the instrument.

### Command Summary

- CALibration[:ALL]?
- CALibration:COUNT?
- CALibration:SECure:CODE <new\_code>
- CALibration:SECure:STATe ON|1|OFF|0,<code>  
CALibration:SECure:STATe?
- CALibration:SETup <step>  
CALibration:SETup?
- CALibration:STRing "<string>"  
CALibration:STRing?
- CALibration:VALue <value>  
CALibration:VALue?

## CALibration[:ALL]?

Performs a calibration using the calibration value (**CALibration:VALue**). The instrument must be unlocked (**CALibration\_SEcure\_STATe OFF,<code>**) to calibrate.

Parameter	Typical Return
(none)	+0 (pass) or +1 (fail)
Calibrate using the current value: <b>CAL?</b>	

### Remarks

- **CALibration:SETup** should always precede the CALibration? query.
- Increments the instrument's calibration count (**CALibration:COUNt?**).
- Modifies the volatile version of the calibration constants. These constants are saved in non-volatile memory at the end of calibration.

## CALibration:COUNt?

Returns the number of calibrations performed. Read and record the initial count when you receive your instrument from the factory.

Parameter	Typical Return
(none)	+117
Return the calibration count: <b>CAL:COUN?</b>	

### Remarks

- Because the value increments for each calibration point (each **CALibration:ALL?**), a complete calibration adds many counts.
- You can display count regardless of whether instrument is secured.
- This setting is non-volatile; it will not be changed by power cycling or **\*RST**.

CALibration:SECure:CODE <new\_code>

Sets the security code to prevent unauthorized calibrations.

Parameter	Typical Return
Unquoted string up to 12 characters Must start with letter (A-Z) May contain letters, numbers (0-9) and underscores	(none)
Set new security code: CAL:SEC:CODE MY_CODE_272	

#### Remarks

- The default security code for both EDU33211A and EDU33212A is EDU3321XA.
- To change code: unsecure calibration memory with the old code, and then set new code.
- This setting is non-volatile; it will not be changed by power cycling or **\*RST**.

CALibration:SECure:STATe ON|1|OFF|0,<code>

CALibration:SECure:STATe?

Unsecures or secures the instrument for calibration. To calibrate, you must unsecure the instrument with the code (**CALibration:SECure:CODE**).

Parameter	Typical Return
ON 1 OFF 0 Default ON	0 (OFF) or 1 (ON)
<code> is an unquoted string up to 12 characters	
Unsecure calibration: CAL:SEC:STAT OFF,MY_CODE_272	
Secure calibration: CAL:SEC:STAT ON	

#### Remarks

- This setting is non-volatile; it will not be changed by power cycling or **\*RST**.
- When shipped from the factory, the instrument is secured with a default code (**CALibration:SECure:CODE**).

CALibration:SETup <step>  
CALibration:SETup?

Configures the calibration step (default 1) to be performed. The instrument must be unlocked (**CALibration\_SEcure\_STATe OFF,<code>**) to calibrate.

Parameter	Typical Return
Whole number Default 1	+16
Prepare for calibration step 5: CAL:SET 5	

**Remarks**

- This setting is non-volatile; it will not be changed by power cycling or **\*RST**.

CALibration:STRing "<string>"  
CALibration:STRing?

Stores a message of up to 40 characters in calibration memory. Common messages include last calibration date, calibration due date, or contact information for calibration department. The instrument must be unlocked (**CALibration\_SEcure\_STATe OFF,<code>**) to store this string.

Parameter	Typical Return
Quoted string up to 40 characters May contain letters, numbers, spaces, and other common characters.	"LAST CAL OCT 31 2011, DUE OCT 31 2012" (If no string stored, returns "")
Sets the string to "FOR CALL HELP, CALL JOE AT EXT 1234": CAL:STR "FOR CAL HELP, CALL JOE AT EXT 1234"	

**Remarks**

- May be stored only from remote interface, with instrument unsecured (**CALibration:SECure:STATe OFF**).
- Storing a calibration message overwrites the previous message.
- This setting is non-volatile; it will not be changed by power cycling or **\*RST**.

CALibration:VALue <value>  
CALibration:VALue?

Specifies the value of the known calibration signal.

Parameter	Typical Return
Numeric Default 0.0	+2.37000000E-002
Specify calibration value 0.0237: CAL:VAL 2.37E-2	

**Remarks**

- This setting is non-volatile; it will not be changed by power cycling or **\*RST**.



## DISPlay Subsystem

The DISPlay subsystem controls the instrument's display.

### Example

The following program turns off the instrument's display.

```
DISP OFF
```

### Command Summary

- **DISPlay ON|1|OFF|0** - enables or disables display

DISPlay ON|1|OFF|0  
DISPlay?

Disables or enables the front panel display. When disabled, the front panel display turns black, and all annunciators are disabled. However, the screen remains on.

Parameter	Typical Return
ON 1 OFF 0 Default ON	0 (OFF) or 1 (ON)
Turn display off: DISP OFF	

**Remarks**

- Disabling the display improves command execution speed from the remote interface and provides basic security.
- The display is enabled when power is cycled, or when you return to local (front panel) operation by pressing the front panel **[Local]** key.

## FORMat Subsystem

### Command Summary

- FORMat:BORder

FORMat:BORDER NORMal|SWAPped  
FORMat:BORDER?

Sets the byte order used in binary data point transfers in the block mode.

Parameter	Typical Return
NORMal SWAPped Default NORMal	NORM or SWAP
Set SWAPped order: FORM:BORD SWAP	

**Remarks**

- **NORMal:** most-significant byte (MSB) of each data point is first. Use this setting if you are using the Keysight IO Libraries.
- **SWAPped:** least-significant byte (LSB) of each data point is first. Most computers use this.

## HCOPy Subsystem

The HCOPy subsystem produces screen images ("screen shots") of the front panel display.

### Example

The following example captures and returns the front panel display image in BMP format.

```
HCOP:SDUM:DATA:FORM BMP  
HCOP:SDUM:DATA?
```

### Command Summary

- **HCOPy:SDUMp:DATA**
- **HCOPy:SDUMp:DATA:FORMat**

## HCOPY:SDUMp:DATA?

Returns the front panel display image ("screen shot")

Parameter	Typical Return
(none)	<i>(A definite-length binary block containing the image.)</i>  Definite-length block data allows any type of device-dependent data to be transmitted as a series of 8-bit binary data bytes. This is particularly useful for transferring large quantities of data or 8-bit extended ASCII codes.

Capture and return the display image: `HCOPY:SDUM:DATA?`

### Remarks

- The image format (BMP) is specified by `HCOPY:SDUMp:DATA:FORMat`.

HCOPY:SDUMp:DATA:FORMat BMP

HCOPY:SDUMp:DATA:FORMat?

Specifies the image format for images returned by `HCOPY:SDUMp:DATA?`.

Parameter	Typical Return
BMP Default BMP	BMP

Set the display image format to BMP: `HCOPY:SDUM:DATA:FORM BMP`

## IEEE-488 Common Commands

This subsystem contains commands and queries associated with the IEEE-488 standards:

### Command Summary

- **\*CLS** - Clear status
- **\*ESE <enable\_value>** - Event status enable
- **\*ESR?** - Event status register query
- **\*IDN?** - Instrument identification
- **\*OPC** - Set operation complete bit
- **\*OPC?** - Wait for current operation to complete
- **\*OPT?** - Show installed options
- **\*PSC 0|1** - Power-on status clear
- **\*RCL 0|1|2|3|4** - Recall instrument state
- **\*RST** - Reset instrument to **factory defaults**
- **\*SAV 0|1|2|3|4** - Save instrument state
- **\*SRE <enable\_value>** - Service request enable (enable bits in enable register of Status Byte Register group)
- **\*STB?** - Read status byte
- **\*TRG** - Trigger command
- **\*TST?** - Self-test
- **\*WAI** - Wait for all pending operations to complete

\*CLS

*Clear Status Command.* Clears the event registers in all register groups. Also clears the error queue.

Parameter	Typical Return
(none)	(none)
Clear event register bits and error queue: *CLS	

\*ESE <enable\_value>

\*ESE?

*Event Status Enable Command and Query.* Enables bits in the **enable register** for the **Standard Event Register** group. The selected bits are then reported to bit 5 of the Status Byte Register.

Parameter	Typical Return
Decimal sum of the bits in the register (table below), default 0. For example, to enable bit 2 (value 4), bit 3 (value 8), and bit 7 (value 128), the decimal sum would be 140 (4 + 8 + 128). Default 0.	+48
Enable bit 4 (value 16) and bit 5 (value 32) in the enable register: *ESE 48	

#### Remarks

- Use **\*PSC** to control whether the Standard Event enable register is cleared at power on. For example, **\*PSC 0** preserves the enable register contents through power cycles.
- **\*CLS** does not clear enable register, does clear event register.

\*ESR?

*Standard Event Status Register Query.* Queries the event register for the **Standard Event Register** group. Register is read-only; bits not cleared when read.

Parameter	Typical Return
(none)	+24
Read the event register (bits 3 and 4 are set): *ESR	

#### Remarks

- Any or all conditions can be reported to the Standard Event summary bit through the enable register. To set the enable register mask, write a decimal value to the register using **\*ESE**.
- Once a bit is set, it remains set until cleared by this query or **\*CLS**.



\*IDN?

*Identification Query.* Returns instrument's identification string.

Parameter	Typical Return
(none)	K-00.00.04-01.00-01.00-01.00-01.00
Return the instrument's identification string: *IDN?	

#### Remarks

- Identification string contains four comma separated fields:
  - Manufacturer name
  - Model number
  - Serial number
  - Revision code
- Identification string is in the following format for the EDU33210 Series instruments:

K-ZZ.zz.zz-AA.aa-BB.bb-CC.cc-DD.dd

---

<b>ZZ.zz.zz</b>	= Instrument revision
<b>AA.aa</b>	= Front panel FW revision
<b>BB.bb</b>	= FW revision
<b>CC.cc</b>	= Arb revision
<b>DD.dd</b>	= FPGA revision

---

\*OPC

Sets "Operation Complete" (bit 0) in the Standard Event register at the completion of the current operation.

Parameter	Typical Return
(none)	(none)
Set Operation Complete bit: *OPC	

#### Remarks

- The purpose of this command is to synchronize your application with the instrument.
- Used in triggered sweep, triggered burst, or list modes to provide a way to poll or interrupt the computer when the **\*TRG** or **INITiate[:IMMediate]** is complete.
- Other commands may be executed before Operation Complete bit is set.
- The difference between **\*OPC** and **\*OPC?** is that **\*OPC?** returns "1" to the output buffer when the current operation completes. This means that no further commands can be sent after an **\*OPC?** until it has responded. In this way an explicit polling loop can be avoided. That is, the IO driver will wait for the response.

## \*OPC?

Returns 1 to the output buffer after all pending commands complete.

Parameter	Typical Return
(none)	1
Return 1 when all previous commands complete: *OPC?	

### Remarks

- The purpose of this command is to synchronize your application with the instrument.
- Other commands cannot be executed until this command completes.
- The difference between \*OPC and \*OPC? is that \*OPC? returns "1" to the output buffer when the current operation completes. This means that no further commands can be sent after an \*OPC? until it has responded. In this way an explicit polling loop can be avoided. That is, the IO driver will wait for the response.

## \*PSC 0|1

### \*PSC?

*Power-On Status Clear.* Enables (1) or disables (0) clearing of two specific registers at power on:

- Standard Event enable register (\*ESE).
- Status Byte condition register (\*SRE).
- Questionable Data Register
- Standard Operation Register

Parameter	Typical Return
0 1	0 or 1
Default 1	
Disables power-on clearing of affected registers: *PSC 0	

\*RCL 0|1|2|3|4  
\*SAV 0|1|2|3|4

Recalls (\*RCL) or saves (\*SAV) instrument state in specified non-volatile location. Previously stored state in location is overwritten (no error is generated).

#### NOTE

For EDU33210 Series instruments, the state files associated with \*SAV and \*RCL are saved in files called STATE\_0.STA through STATE\_4.STA. These files are located in the Settings directory of internal memory. You can manage these files using [MMEMory commands](#).

Parameter	Typical Return
0 1 2 3 4	(none)
Recall state from location 1: *RCL 1	

#### Remarks

- The instrument has five non-volatile storage locations to store instrument states. Location 0 holds the instrument power down state. Use locations 1, 2, 3, and 4 to store other states. You can configure the instrument to recall the power-down state when power is restored ([MEM:STAT:REC:AUTO](#)).
- State storage "remembers" the selected function (including arbitrary waveforms), frequency, amplitude, DC offset, duty cycle, symmetry, as well as any modulation parameters in use.
- When shipped from the factory, locations 1 through 4 are empty, and location 0 has power-on state.
- You can [assign a user-defined name](#) to each of locations 0 through 4.
- States stored in memory are not affected by [\\*RST](#).
- If you delete an arbitrary waveform from non-volatile memory after storing the instrument state, the waveform data is lost and the instrument will not output the waveform when the state is recalled; it will output the built-in "exponential rise" instead.
- The front panel uses [MMEMory subsystem](#) for state storage.

\*RST

Resets instrument to [factory default state](#), independent of [MEMory:STATe:RECall:AUTO](#) setting.

Parameter	Typical Return
(none)	(none)
Reset the instrument: *RST	

#### Remarks

- Does not affect stored instrument states, stored arbitrary waveforms, or I/O settings; these are stored in non-volatile memory.
- Aborts a sweep or burst in progress.

\*SRE <enable\_value>  
 \*SRE?

*Service Request Enable.* This command enables bits in the **enable register** for the **Status Byte Register** group.

Parameter	Typical Return
Decimal sum of the bits in the register (table below), default 0. For example, to enable bit 2 (value 4), bit 3 (value 8), and bit 7 (value 128), the decimal sum would be 140 (4 + 8 + 128). Default 0.	+24
Enable bits 3 and 4 in the enable register: *SRE 24	

- To enable specific bits, specify the decimal value corresponding to the binary-weighted sum of the bits in the register. The selected bits are summarized in the "Master Summary" bit (bit 6) of the Status Byte Register. If any of the selected bits change from 0 to 1, the instrument generates a Service Request signal.
- **\*CLS** clears the event register, but not the enable register.
- **\*PSC** (power-on status clear) determines whether Status Byte enable register is cleared at power on. For example, **\*PSC 0** preserves the contents of the enable register through power cycles.
- Status Byte enable register is not cleared by **\*RST**.

\*STB?

*Read Status Byte Query.* This command queries the condition register for the **Status Byte Register** group.

Parameter	Typical Return
(none)	+40
Read condition register (with bits 3 and 5 set): *STB?	

**Remarks**

- Similar to a Serial Poll, but processed like any other instrument command. Register is read-only; bits not cleared when read.
- Returns same result as a Serial Poll, but "Master Summary" bit (bit 6) is not cleared by \*STB?.
- Power cycle or **\*RST** clears all bits in condition register.
- Returns a decimal value that corresponds to the binary-weighted sum of all bits set in the register. For example, with bit 3 (value 8) and bit 5 (value 32) set (and corresponding bits enabled), the query returns +40.

## \*TRG

*Trigger Command.* Triggers a sweep, burst, arbitrary waveform advance, or **LIST** advance from the remote interface if the bus (software) trigger source is currently selected (**TRIGger[1|2]:SOURce BUS**).

Parameter	Typical Return
(none)	(none)
Send immediate trigger to initiate a burst: BURS:STAT ON BURS:MODE TRIG TRIG:SOUR BUS <b>*TRG</b>	

## \*TST?

*Self-Test Query.* Performs a complete instrument self-test. If test fails, one or more error messages will provide additional information. Use **SYSTem:ERRor?** to read error queue.

Parameter	Typical Return
(none)	+0 (pass) or +1 (one or more tests failed)
Perform self-test: <b>*TST?</b>	

### Remarks

- A power-on self-test occurs when you turn on the instrument. This limited test assures you that the instrument is operational.
- A complete self-test (**\*TST?**) takes approximately 15 seconds. If all tests pass, you have high confidence that the instrument is fully operational.
- Passing **\*TST** displays "Self-Test Passed" on the front panel. Otherwise, it displays "Self-Test Failed".

## \*WAI

Configures the instrument to wait for all pending operations to complete before executing any additional commands over the interface.

Parameter	Typical Return
(none)	(none)
Wait until all pending operations complete: <b>*WAI</b>	

### Remarks

- For example, you can use this with the **\*TRG** command to ensure that the instrument is ready for a trigger:  
**\*TRG;\*WAI;\*TRG**

## INITiate Subsystem

The INITiate subsystem controls how the instrument moves from the "idle" state to the "wait for trigger" state. You may do this one channel at a time, or for both channels with the "ALL" keyword.

### Example

This program uses **INITiate[1|2][:IMMEDIATE]** with **TRIGger[1|2]:SOURce** and **TRIGger[1|2]:COUNT**. The **TRIG:SOUR EXT** command configures the channel for external triggering, and **TRIG:COUNT** sets the trigger count to 10. The **INITiate** command places the instrument in the "wait-for-trigger" state. The trigger will occur when the front-panel **Ext Trig** line is pulsed (high by default). The channel will return to idle after the trigger count of 10 has been satisfied. Another INIT command would then be necessary to restart the acceptance of triggers from the external trigger input line.

```
INIT:CONT OFF
TRIG:SOUR EXT
TRIG:COUNT 10
INIT
```

### Command Summary

- **INITiate[:IMMEDIATE]**

INITiate[1|2]:CONTInuous ON|1|OFF|0  
INITiate[1|2]:CONTInuous?  
INITiate:CONTInuous:ALL ON|1|OFF|0

Specifies whether the trigger system for one or both channels (ALL) always returns to the "wait-for-trigger" state (ON) or remains in the "idle" state (OFF), ignoring triggers until **INITiate:IMMEDIATE** is issued.

Parameter	Typical Return
ON 1 OFF 0 Default ON	0 (OFF) or 1 (ON)
Configure both channels for continuous trigger: <code>INIT:CONT:ALL ON</code>	

#### Remarks

- Once the channel is triggered, it leaves the wait-for-trigger state and enters the "action-in-progress" state (for example, burst-in-progress or sweep-in-progress). The action-in-progress state can be lengthy, and during this state triggers are ignored (will not count against number of triggers specified by **TRIGger[1|2]:COUNT**).
- With INIT:CONT ON, the trigger count is meaningless because there is no way to distinguish the completion of one trigger count from the first trigger of the next trigger count. If you need counted triggers, you must set INIT:CONT OFF.

INITiate[1|2][:IMMEDIATE]  
INITiate[:IMMEDIATE]:ALL

Changes state of triggering system for both channels (ALL) from "idle" to "wait-for-trigger" for the number of triggers specified by **TRIGGER[1|2]:COUNT**.

- Once the channel is triggered, it leaves the wait-for-trigger state and enters the "action-in-progress" state (for example, burst-in-progress or sweep-in-progress). The action-in-progress state can be lengthy, and during this state triggers are ignored (will not count against number of triggers specified by **TRIGGER[1|2]:COUNT**).

Parameter	Typical Return
(none)	(none)
Change both channels to the wait-for-trigger state: <b>INIT:IMM:ALL</b>	

#### Remarks

- The trigger system is armed by **INITiate[:IMMEDIATE]**. Once the trigger count is satisfied, the trigger system returns to idle state and ignores further triggers. The triggered function will be left in whatever state is achieved with the count of triggers. Rearming the trigger system with another **INITiate[:IMMEDIATE]** allows further triggers to apply.
- Use **ABORT** to return instrument to idle.
- If the specified channel has **INIT:CONT** set ON, **INITiate[1|2]:IMMEDIATE** and **INIT[:IMMEDIATE]:ALL** have no effect on the trigger system and error -213 will be generated.



## LXI Subsystem

The LXI subsystem supports LAN eXtensions for Instrumentation (LXI) functionality.

### Command Summary

- LXI:IDENtify[:STATE] ON|1|OFF|0
- LXI:IDENtify[:STATE]?
- LXI:MDNS:ENABLe ON|1|OFF|0
- LXI:MDNS:ENABLe?
- LXI:MDNS[:STATe] ON|1|OFF|0
- LXI:MDNS[:STATe]?
- LXI:MDNS:HNAME[:RESolved]?
- LXI:MDNS:SNAME:DESired <name>
- LXI:MDNS:SNAME:DESired?
- LXI:MDNS:SNAME[:RESolved]?
- LXI:RESet
- LXI:REStart

LXI:IDENTify[:STATE] ON|1|OFF|0  
 LXI:IDENTify[:STATE]?

Turns the LXI Identify Indicator on the display on or off.

Parameter	Typical Return
ON 1 OFF 0	0 (OFF) or 1 (ON)
Turn on the LXI Identify Indicator: LXI:IDEN ON	

**Remarks**

- The LXI Identify indicator helps you identify the device associated with the LAN address.
- A **\*RST** turns LXI Identify Indicator off.

LXI:MDNS:ENABLE ON|1|OFF|0  
 LXI:MDNS:ENABLE?  
 LXI:MDNS[:STATE] ON|1|OFF|0  
 LXI:MDNS[:STATE]?

Disables or enables the Multicast Domain Name System (mDNS).

Parameter	Typical Return
ON 1 OFF 0	0 (OFF) or 1 (ON)
Default ON	
Turn mDNS ON: LXI:MDSN:ENAB ON	

**Remarks**

- Setting is enabled after LAN reset.

LXI:MDNS:HNAME[:RESolved]?

Returns the resolved (unique) mDNS hostname in the form "K-<model number>-<serial>-N", where <serial> is the last 5 digits of the instrument's serial number. The N is an integer appended if necessary to make the name unique.

The desired name may be truncated, if necessary, to make room for the appended integer.

Parameter	Typical Return
(none)	"K-33xxx-yyyy.local", where xxx is the last four characters of the model number, and yyyy is the last five digits of the serial number.
Returns the resolved mDNS hostname: LXI:MDNS:HNAME:RESolved?	

LXI:MDNS:SNAME:DESired <name>  
LXI:MDNS:SNAME:DESired?

Sets the desired mDNS service name.

Parameter	Typical Return
Quoted string of up to 63 characters, default is Keysight <Model_Name> Arbitrary Waveform Generator - <Serial_Number>".	"Keysight EDU33xxx Arbitrary Waveform Generator - yyyyyyyyyy", where xxx is the last four characters of the model number, and yyyyyyyyyy is the full serial number of 10 digits.
Set the mDNS service name to "Waveform Generator": LXI:MDNS:SNAM:DES "Waveform Generator"	

#### Remarks

- This setting is non-volatile; it will not be changed by power cycling or \*RST.

LXI:MDNS:SNAME[:RESolved]?

Returns the resolved (unique) mDNS service name in the form <Desired mDNS Service Name>(N). The N is an integer appended if necessary to make the name unique. The desired name may be truncated, if necessary, to make room for the appended integer.

Parameter	Typical Return
(none)	"Keysight EDU33xxx Arbitrary Waveform Generator - yyyyyyyyyy", where xxx is the last four characters of the model number, and yyyyyyyyyy is the full serial number of 10 digits.
Return resolved mDNS service name: LXI:MDNS:SNAME:RESolved?	

#### Remarks

- The resolved mDNS service name is the desired service name (LXI:MDNS:SNAME:DESired), possibly with "(N)" appended, where N is an integer, only if it is necessary to make the name unique.

LXI:RESet

Resets LAN settings to a known operating state, beginning with DHCP. If DHCP fails, it uses AutoIP. It also clears the WebUI password, if set.

Parameter	Typical Return
(none)	(none)
Reset the LAN settings: LXI:RES	

#### Remarks

- Depending on your network, the LAN interface may take several seconds to restart after this command is sent.

## LXI:REStart

Restarts the LAN with the current settings as specified by the SYSTem:COMMunicate:LAN commands.

Parameter	Typical Return
(none)	(none)
Restart the LAN interface: LXI:REST	

### Remarks

- Depending on your network, the LAN interface may take several seconds to restart after this command is sent.

## MEMory Subsystem

The MEMory subsystem works with instrument state files that are saved to (**\*SAV**) and recalled from (**\*RCL**) non-volatile storage locations numbered 0 through 4.

### NOTE

For EDU33210 Series instruments, the state files associated with **\*SAV** and **\*RCL** are saved in files called STATE\_0.STA through STATE\_4.STA. These files are located in the Settings directory of internal memory. You can manage these files using **MMEMory commands**.

### Example

```
MEM:STAT:DEL 3
*SAV 3
MEM:STAT:VAL? 3
MEM:STAT:NAME 3,PATS_STATE
MEM:STAT:CAT?
```

### Command Summary

- **MEMory:NSTates?** - return total number of state storage memory locations
- **MEMory:STATe:CATalog?** - list the names associated with all five state storage locations
- **MEMory:STATe:DELeTe 0|1|2|3|4** - delete the contents of a state storage location
- **MEMory:STATe:NAME 0|1|2|3|4 [,<name>]** - assign a custom name to a state storage locations
- **MEMory:STATe:RECall:AUTO ON|1|OFF|0** - specify whether the power-down state is recalled from location 0 on power-on
- **MEMory:STATe:VALid? 0|1|2|3|4** - determine whether a storage location contains a valid state

## MEMory:NStates?

Returns the total number of memory locations available for state storage (always +5, including memory location 0).

Parameter	Typical Return
(none)	+5
Return number of state storage locations: MEM:NST?	

## MEMory:STATe:CATalog?

Returns the names assigned to locations 0 through 4.

Parameter	Typical Return
(none)	"AUTO_RECALL", "STATE_1", "STATE_2", "STATE_3", or "STATE_4"
Return location names: MEM:STAT:CAT?	

### Remarks

- Default names are "AUTO\_RECALL", "STATE\_1", "STATE\_2", "STATE\_3", and "STATE\_4".
- You can name location 0, but the name is overwritten when power is cycled and a new power-down state is stored there.

## MEMory:STATe:DELeTe 0|1|2|3|4|

Deletes a state storage location.

Parameter	Typical Return
0 1 2 3 4	(none)
Delete the contents of storage location 1: MEM:STAT:DEL 1	

### Remarks

- Default names are "AUTO\_RECALL", "STATE\_1", "STATE\_2", "STATE\_3", and "STATE\_4".
- Although you may delete the state in location 0, the instrument will be restored to its power-down state at the next power up.
- Attempting to recall a state from an empty location generates an error.

MEMory:STATe:NAME 0|1|2|3|4 [,<name>]  
MEMory:STATe:NAME? 0|1|2|3|4

Names a storage location.

Parameter	Typical Return
An unquoted string of up to 12 characters. The first character must be a letter (A-Z). Others can be letters, numbers (0-9), or underscores ("_"). If name omitted, factory default name is used.	TEST_RACK_1
Rename location 1: MEM:STAT:NAME 1,TEST_RACK_1	

#### Remarks

- Default names are "AUTO\_RECALL", "STATE\_1", "STATE\_2", "STATE\_3", and "STATE\_4".
- May assign same name to different locations.
- Deleting a storage location's contents (**MEMory:STATe:DELeTe**) resets associated name to factory default ("AUTO\_RECALL", "STATE\_1", "STATE\_2", "STATE\_3", or "STATE\_4").
- State names are unaffected by **\*RST**.

MEMory:STATe:RECall:AUTO ON|1|OFF|0  
MEMory:STATe:RECall:AUTO?

Disables or enables automatic recall of instrument state in storage location "0" at power on.

Parameter	Typical Return
ON 1 OFF 0 Default ON	0 (OFF) or 1 (ON)
Disable automatic recall of power-down state: MEM:STAT:REC:AUTO OFF	

#### Remarks

- OFF is equivalent to Factory Reset (**\*RST**) on power-up.

MEMory:STATe:VALid? 0|1|2|3|4

Indicates whether a valid state is currently stored in a storage location.

Parameter	Typical Return
0 1 2 3 4	0 (no valid state stored) or 1 (valid state stored)
Return state of memory location 3: MEM:STAT:VAL 3?	

#### Remarks

- Use this before sending **\*SAV** to avoid accidentally overwriting a state.

## MMEMory Subsystem

The MMEMory subsystem manages the file system in the external USB file system. The file system can store and load several file formats.

The "INT:\BUILTIN\" flash memory file system inside the instrument is always present for internal built-in arbitrary waveform. If a USB file storage device (sometimes called a flash drive, thumb drive, or jump drive) is plugged into the front panel USB port, it appears as "USB:\" to the instrument.

### Example

```
DATA:VOL:CLEAR <--- erase all waveforms
FUNC:ARB:SRATE 10E3
FUNC:ARB:FILTER OFF
FUNC:ARB:PTPEAK 10
DATA:ARB dc_ramp, 0.1, 0.1, 0.1, 0.1, 0.1, 0.2, 0.4, 0.6, 0.8, 1.0
DATA:ARB dc5v, 1.0, 1.0, 1.0, 1.0, 1.0, 1.0, 1.0, 1.0, 1.0, 1.0
DATA:ARB dc2_5v, 0.5, 0.5, 0.5, 0.5, 0.5, 0.5, 0.5, 0.5, 0.5, 0.5
DATA:ARB dc0v, 0.0, 0.0, 0.0, 0.0, 0.0, 0.0, 0.0, 0.0, 0.0, 0.0
FUNC:ARB dc_ramp
MMEM:STORE:DATA "USB:\dc_ramp.arb"
FUNC:ARB dc5v
MMEM:STORE:DATA "USB:\dc5v.arb"
FUNC:ARB dc2_5v
MMEM:STORE:DATA "USB:\dc2_5.arb"
FUNC:ARB dc0v
MMEM:STORE:DATA "USB:\dc0v.arb"
DATA:VOL:CAT? <--- list all loaded waveforms
FUNC ARB
OUTPUT ON
```



## Command Summary

The MMEMory subsystem includes the following commands and queries.

- **MMEMory:CATalog[:ALL]? [<folder>]** - lists available and used space and files on Mass Memory device
- **MMEMory:CATalog:DATA:ARBitrary? [<folder>]** - lists arbitrary waveforms on Mass Memory device
- **MMEMory:CATalog:STATe? [<folder>]** - lists available and used space and state (\*.sta) files present on Mass Memory device
- **MMEMory:CDIRectory <folder>** - changes to a directory  
**MMEMory:CDIRectory?**
- **MMEMory:COpy <file1>,<file2>** - copies a file on Mass Memory device
- **MMEMory:DELeTe <file>** - removes files from Mass Memory device
- **MMEMory:DOWNload:DATA <binary\_block>** - downloads data from the host computer to instrument's Mass Memory
- **MMEMory:DOWNload:FNAME <filename>** - specifies file name for downloading data from the computer to instrument's Mass Memory
- **MMEMory:LOAD:ALL <filename>** - loads instrument state file
- **MMEMory:LOAD:DATA[1|2] <filename>** - loads arbitrary waveform from file
- **MMEMory:LOAD:LIST[1|2] <filename>** - loads frequency list from file
- **MMEMory:LOAD:STATe <filename>** - loads saved instrument state from file
- **MMEMory:MDIRectory <folder>** - makes a new directory (folder)
- **MMEMory:MOVE <file1>,<file2>** - moves a file on Mass Memory device
- **MMEMory:RDIRectory <folder>** - removes a directory
- **MMEMory:STORe:ALL <filename>** - saves instrument state file
- **MMEMory:STORe:DATA[1|2] <filename>** - saves arbitrary waveform to file
- **MMEMory:STORe:LIST[1|2] <filename>** - saves active frequency list to file
- **MMEMory:STORe:STATe <filename>** - stores instrument state to file
- **MMEMory:UPLoad? <filename>** - uploads contents of a file from instrument to host computer

## Folder and file formats

Many MMEMory commands refer to folders and files. These have specific structures, described below.

### Format for a <folder>

- The format for <folder> is "<drive>:<path>", where <drive> can be INTernal or USB, and <path> is an absolute folder path.
  - INTernal specifies the internal flash file system.USB specifies a front panel USB storage device.
  - Absolute paths begin with "\" or "/" and start at the root folder of <drive>.
  - The folder name specified in <path> cannot exceed 240 characters.
  - The specified folder must exist and cannot be marked hidden or system.
  - If <drive>:<path> is omitted, the folder specified by **MMEMory:CDIRectory** is used.
  - If <drive> is omitted:
    - The path is treated as a relative path and appended to the folder specified by **MMEMory:CDIRectory**.
    - Absolute paths are NOT allowed.

### Format for a <file>

- The format for <file1> and <file2> is "[<drive>:<path>]<file\_name>", where <drive> can be INTernal or USB, and <path> must be an absolute folder path.
  - INTernal specifies the internal flash file system.USB specifies a front panel USB storage device.
  - If <drive>:<path> is omitted, the folder specified by **MMEMory:CDIRectory** is used.
  - Absolute paths begin with "\" or "/" and start at the root folder of <drive>.
  - Folder and file names cannot contain the following characters: \ / : \* ? " < > |
  - The combination of folder and file name cannot exceed 240 characters.
  - The source file and folder and the destination folder must exist and cannot be marked hidden or system.
  - If the destination file exists, it is overwritten, unless marked as hidden or system.
  - If <drive> is omitted:
    - The path is treated as a relative path and appended to the folder specified by **MMEMory:CDIRectory**.
    - Absolute paths are NOT allowed.

## Mass Memory (MMEMory) and State Storage

The front panel uses the MMEM subsystem, not the MEM subsystem, to save states. If you save a state with the front panel, you can still access it with SCPI. However, a state saved into the MEM subsystem via SCPI using \*SAV cannot be retrieved from the front panel.

For example, configure the instrument as desired and insert a USB drive into the front panel. Then enter the following commands.

```
MMEMory:CDIRectory "USB:\"  
MMEMory:MDIRerctory "USB:\States"  
MMEMory:STORe:STATE "USB:\States\State1"
```

To return to this state at any time:

```
MMEMory:LOAD:STATE "USB:\States\State1"
```

You can also recall a state file from the front panel by pressing **[System] > Store/Recall**.

MMEMory:CATalog[:ALL]? [<folder>]

Returns a list of all files in the current mass storage directory, including internal storage and the USB drive.

Parameter	Typical Return
Any valid folder name; defaults to folder selected by <b>MMEMory:CDIRectory</b>	+1000000000,+327168572, "command.exe,,375808", "MySetup.sta,STAT,8192", "MyWave.csv,ASC,11265"

List all files in the folder MyData on the front panel USB storage device:

MMEM:CAT? "USB:\MyData"

#### Remarks

- The catalog takes the following form:  
<mem\_used>,<mem\_free>{,"<file\_listing>"}

The instrument returns two numeric values and a string for each file in the folder. The first numeric value indicates the number of bytes of storage used on the drive. The second indicates the number of bytes of storage available. Each <file\_listing> is in the format "<file\_name>,<file\_type>,<file\_size>" (the quotation marks are also returned), where <file\_name> is the name of the file including file extension, if any; <file\_type> is either STAT for STATE (.sta) files, ASC for DATA (.csv) files, FOLD for folders, or null for all other file extensions; <file\_size> is the size of the file in bytes.

- If no files exist, only <mem\_used>,<mem\_free> is returned.

## MMEMory:CATalog:DATA:ARbitrary? [<folder>]

Returns a list of all the arbitrary waveform (.arb) files in a folder.

Parameter	Typical Return
Any valid folder name; defaults to folder selected by <b>MMEMory:CDIRectory</b> (see below)	
The following query lists all arbitrary waveform in the BuiltIn directory of internal memory: MMEM:CAT:DATA:ARbitrary? "INT:\BuiltIn"	
Typical Response: "+13735,+0,"EXP_RISE.arb,ARB,1868","EXP_FALL.arb,ARB,2064", "SINC.arb,ARB,1897","CARDIAC.arb,ARB,2410","NEG_RAMP.arb,ARB,1908", "HAVERSINE.arb,ARB,374","GAUSSIAN.arb,ARB,587","LORENTZ.arb,ARB,1254", "D_LORENTZ.arb,ARB,1373"	

### Remarks

- The instrument returns two numeric values and a string for each .arb file in the selected folder. The first numeric value indicates the number of bytes of storage used on the drive. The second indicates the number of bytes of storage available. Each <file listing> is in the format "<filename>,<file\_type>,<file\_size>" (the quotation marks are also returned), where <filename> is the name of the file including file extension, if any; <file\_type> is FOLD for folders, or ARB for arb segments; <file\_size> is the size of the file in bytes.
- If no .arb files exist, only <mem\_used>,<mem\_free> is returned.

## MMEMory:CATalog:STATe? [<folder>]

Lists all state files (.sta file extension) in a folder.

Parameter	Typical Return
Any valid folder name; defaults to folder selected by <b>MMEMory:CDIRectory</b> +1000000000,+327168572,"MySetup.sta,STAT,8192"	
List all state files in MyData folder on front panel USB drive: MMEM:CAT:STAT? "USB:\MyData"	

### Remarks

- Format for returned catalog:  
<mem\_used>,<mem\_free>{,<file listing>}
- The instrument returns two numeric values and a string for each state file in the selected folder. The first numeric value indicates the number of bytes of storage used on the drive. The second indicates the number of bytes of storage available. Each <file listing> is in the format "<file\_name>,<file\_type>,<file\_size>" (the quotes are also returned), where <file\_name> is the name of the file including file extension, if any; <file\_type> is STAT for STATe (.sta) files; <file\_size> is the size of the file in bytes.
- If no state files exist, only <mem\_used>,<mem\_free> is returned.

MMEMory:CDIRectory <folder>  
 MMEMory:CDIRectory?  
 MMEMory:MDIRectory <folder>  
 MMEMory:RDIRectory <folder>

MMEMory:CDIRectory selects the default folder for the MMEMory subsystem commands. This folder must exist and is used when folder or file names do not include a drive and folder name.

MMEMory:MDIRectory makes a new directory (folder) on the mass storage medium.

MMEMory:RDIRectory removes a directory (folder) on the mass storage medium.

Parameter	Typical Return
Any directory name, including the mass storage unit specifier, default INT:\ "INT:\"	
Make and remove a new directory named "test" on the external mass memory system: MMEM:MDIR "USB:\test" MMEM:RDIR "USB:\test"	
Return the default folder for MMEMory subsystem commands: MMEM:CDIR?	

**Remarks**

- The instrument resets the default folder to the internal flash file system root directory ("INT:\") after **\*RST**.
- You can only remove an empty folder (no files). Otherwise, the instrument generates a "Directory not empty" error.

MMEMory:COPY <file1>,<file2>

Copies <file1> to <file2>. The file names must include any file extension.

Parameter	Typical Return
Both files can be any valid file name	(none)
Copy the state file MyFreqMeas.sta from the root directory to the folder "Backup" on the external flash file system: MMEM:COPY "USB:\MySetup.sta","USB:\Backup\MySetup.sta"	

## MMEMory:DELeTe <file>

Deletes a file. To delete a folder, use MMEMory:RDIRECTory.

Parameter	Typical Return
Any valid file name, including file extension.	(none)
Delete the indicated file from the root directory of the external flash file system: MMEM:DEL "USB:\MySetup.sta"	

### Remarks

- You may also use wildcards with this command. For example, MMEM:DEL "USB:\MYDATA\\*.csv" will erase all of the CSV files in the specified directory.

## MMEMory:DOWNload:DATA <binary\_block>

Downloads data from the host computer to a file in the instrument. The filename must have been previously specified by **MMEMory:DOWNload:FNAME**.

The data in <binary\_block> is written to the select file, and any data previously stored in the file is lost.

Parameter	Typical Return
Any IEEE-488 definite or indefinite block	(none)
Writes the word "Hello" to the file "\Myfile" on external storage: MMEM:DOWN:FNAME "USB:\Myfile" MMEM:DOWN:DATA #15Hello	

## MMEMory:DOWNload:FNAME <filename>

### MMEMory:DOWNload:FNAME?

Creates or opens the specified filename prior to writing data to that file with **MMEMory:DOWNload:DATA**.

Parameter	Typical Return
Any valid file name	(none)
Write the word "Hello" to the file "\Myfile" on the external flash file system: MMEM:DOWN:FNAME "USB:\Myfile" MMEM:DOWN:DATA #15Hello	

MMEMory:LOAD:ALL <filename>  
 MMEMory:STORe:ALL <filename>

Loads or saves a complete instrument setup, using a named file on the mass storage.

Parameter	Typical Return
Any valid file name on current mass storage directory	(none)
Store instrument setup to file named "completeSetup.all" on external storage: MMEM:STOR:ALL "USB:\completeSetup.all"	
Load a complete instrument setup from the file in external mass memory: MMEM:LOAD:ALL "USB:\completeSetup.all"	

**Remarks**

- These commands allow you to duplicate instrument conditions from some previous time.
- This command loads the current instrument setup (such as is used by \*SAV and \*RCL).
- Instrument setup files used by these commands contain much more than the state files used by \*SAV and \*RCL. They also contain stored states and arbitrary waveforms, beep on/off, display options, and help language.
- If the destination file exists, it is overwritten, unless marked as hidden or system.

MMEMory:LOAD:DATA[1|2] <filename>

Loads the specified arb segment (.arb) in USB memory into volatile memory for the specified channel.

Parameter	Typical Return
Any valid file name, as described below.	(none)
Load an arbitrary waveform segment from the internal drive into volatile memory for channel 1 and selects it for use: MMEM:LOAD:DATA "Int:\Builtin\HAVERSINE.arb" FUNC:ARB "Int:\Builtin\HAVERSINE.ARB"	

**Remarks**

- If the waveform referenced by <filename> has already been loaded, the instrument will generate error number +786, "Specified arb waveform already exists". Deleting an existing waveform requires clearing the waveform non-volatile memory with DATA:VOLatile:CLEar.



MMEMemory:LOAD:LIST[1|2] <filename>  
MMEMemory:STORe:LIST[1|2] <filename>

Loads or stores a frequency list file (.lst).

Parameter	Typical Return
Any valid file name on the mass memory device	(none)
Store the current frequency list to a LIST file on external storage: MME:STOR:LIST "USB:\FreqList.lst"	
Load a LIST file on the external storage mass memory system (file named FreqList.lst): MME:LOAD:LIST "USB:\FreqList.lst"	

#### Remarks

- A frequency list controls frequency in **FREQ:MODE LIST**, rapidly changing to the next frequency in the list when a trigger event is received.
- A frequency list file contains a comma-separated sequence of ASCII numbers, with the first number representing the number of frequencies in the list:  
3, 100.000000, 1000.000000, 550.000000
- If the destination file exists, it is overwritten, unless marked as hidden or system.

MMEMemory:LOAD:STATe <filename>  
MMEMemory:STORe:STATe <filename>

Stores the current instrument state to a state file. The file name optionally includes the folder name and the .sta file extension.

Parameter	Typical Return
Any valid file name on the current directory	(none)
Store the current instrument state to the state file MyFreqMeas.sta in the root directory of the external flash file system: MME:STOR:STAT "USB:\MySetup"	
Load the instrument state from MySetup.sta in the root directory of the external storage: MME:LOAD:STAT "USB:\MySetup.sta"	

MMEMory:MOVE <file1>,<file2>

Moves and/or renames <file1> to <file2>. The file names must include the file extension.

Parameter	Typical Return
Both files may be any valid file name	(none)
Move the state file MySetup.sta from the currently selected default directory to the folder "Backup" on the external flash file system: MMEM:MOVE "USB:\MySetup.sta","USB:\Backup\MySetup.sta"	
Rename the arbitrary waveform arbMonday on the USB drive to the name arbTuesday: MMEM:MOVE "USB:\arbMonday","USB:\arbTuesday"	

#### Remarks

- To simply rename a file, specify the same folder for <file1> and <file2>.
- To move a file to a file of the same name in a different folder, you can specify just the <drive>:<path> for <file2>.

MMEMory:STOR:DATA[1|2] <filename>

Stores the specified arb segment (.arb) data in the channel specified volatile memory (default, channel 1) in USB memory.

Parameter	Typical Return
Any valid file name	(none)
Store an arbitrary segment loaded in volatile memory on channel 1 to the USB drive: MMEM:STOR:DATA "USB:\Segment1.arb"	

#### Remarks

- When you store an arbitrary waveform segment (**MMEMory:STOR:DATA[1|2]**), the instrument's current settings (voltage values, sample rate, filter type, and so on) are stored in the segment file. When you play the file for the first time with **FUNCTION:ARbitrary**, these settings are loaded and override the instrument's current settings. If you have manually edited a segment file such that the instrument settings have been removed, the instrument settings will not be changed when you execute **FUNCTION:ARbitrary**.
- If the destination file exists, it is overwritten, unless marked as hidden or system.
- Command will error if the specified arbitrary waveform segment is not found in volatile memory.

MMEemory:UPLoad? <filename>

Uploads the contents of a file from the instrument to the host computer.

Parameter	Typical Return
Any valid file name	IEEE 488.2 definite-length block

The following command uploads the contents of the state file "Myfile.sta" in the root directory of the external flash file system to the host computer:

```
MMEemory:UPL? "USB:\Myfile.sta"
```

## OUTPut Subsystem

The OUTPut subsystem controls the front panel channel output and **Sync** connectors and the front-panel **Ext Trig** connector:

- **OUTPut[1|2][:STATe] ON|1|OFF|0** - front panel channel output connector state
- **OUTPut[1|2]:LOAD <ohms>|INFinity|MINimum|MAXimum|DEFault** - output termination impedance
- **OUTPut[1|2]:MODE NORMAl|GATed** - channel output mode
- **OUTPut[1|2]:POLarity NORMAl|INVerted** - output waveform polarity
- **OUTPut:SYNC[:STATe] ON|1|OFF|0** - front panel **Sync** connector state
- **OUTPut[1|2]:SYNC:MODE?** - sync signal mode
- **OUTPut[1|2]:SYNC:POLarity NORMAl|INVerted** - sync waveform polarity
- **OUTPut:SYNC:SOURce CH1|CH2** - channel used to drive sync signal
- **OUTPut:TRIGger[:STATe] ON|1|OFF|0** - front-panel **Ext Trig** connector state
- **OUTPut:TRIGger:SLOPe POSitive|NEGative** - "trigger out" polarity
- **OUTPut:TRIGger:SOURce CH1|CH2** - channel for driving output trigger

OUTPut[1|2][:STATe] ON|1|OFF|0  
OUTPut[1|2][:STATe]?

Enables or disables the front panel output connector.

Parameter	Typical Return
ON 1 OFF 0 Default OFF	0 (OFF) or 1 (ON)
Enable output connector for channel 1: OUTP ON	

#### Remarks

- When output is enabled, the front panel channel output key is illuminated.
- The **APPLY** commands override current OUTPut setting and enable the channel output connector.
- If excessive external voltage is applied to the front panel channel output connector, an error message appears and output is disabled. To re-enable output, remove overload from the output connector and send OUTPut ON.
- OUTPut changes the state of the channel output connector by switching the output relay, without zeroing output voltage. Therefore, output may glitch for about a millisecond until signal stabilizes. Minimize glitching by first minimizing amplitude (**VOLTage MIN**) and setting offset to 0 (**VOLTage:OFFSet 0**) before changing output state.
- This command also toggles the output impedance between 50  $\Omega$  (ON) and high (>1M $\Omega$ ) impedance (OFF).

OUTPut[1|2]:LOAD <ohms>|INFinity|MINimum|MAXimum|DEFault  
 OUTPut[1|2]:LOAD? [MINimum|MAXimum]

Sets expected output termination. Should equal the load impedance attached to the output.

Parameter	Typical Return
1 $\Omega$ to 10 k $\Omega$ Default 50 $\Omega$	+5.000000000000000E+02
Set output impedance to 300 $\Omega$ : OUTP:LOAD 300	
Set output impedance to "high impedance": OUTP:LOAD INF	

#### Remarks

- The specified value is used for amplitude, offset, and high/low level settings.
- The instrument has a fixed series output impedance of 50  $\Omega$  to the front panel channel connectors. If the actual load impedance differs from the value specified, the displayed amplitude and offset levels will be incorrect. The load impedance setting is simply a convenience to ensure that the displayed voltage matches the expected load.
- If you change the output termination setting, the displayed output amplitude, offset, and high/low levels are adjusted (with no error generated). If the amplitude is 10 Vpp and you change the output termination setting from 50  $\Omega$  to "high impedance" (OUTPut[1|2]:LOAD INF), the displayed amplitude doubles to 20 Vpp. Changing from "high impedance" to 50  $\Omega$  halves the displayed amplitude. The output termination setting does not affect the actual output voltage; it only changes the values displayed and queried from the remote interface. Actual output voltage depends on the connected load.
- You cannot specify output amplitude in dBm if output termination is set to high impedance. The units are automatically converted to Vpp. See VOLT:UNIT for details.
- You cannot change the output termination setting with voltage limits enabled; the instrument cannot know which output termination settings the voltage limits apply to. To change the output termination setting, disable voltage limits, set the new termination value, adjust voltage limits, and re-enable voltage limits.
- If INF (high impedance) is selected, the query returns 9.9E+37.

OUTPut[1|2]:MODE NORMAl|GATed  
 OUTPut[1|2]:MODE?

Enables (GATed) or disables (NORMAl) gating of the output waveform signal on and off using the trigger input.

Parameter	Typical Return
NORMAl GATed Default NORMAl	GAT or NORM
Enable gated output: OUTP:MODE GAT	

**Remarks**

- The effect of gating is independent of waveform phase or timing of any sort. When trigger input is asserted, the output signal is generated. When trigger is not asserted, the waveform continues to be generated internally, but it is not routed to channel output connector.
- Gating does not change channel output termination (does not operate output on/off relay).

OUTPut[1|2]:POLarity NORMAl|INVerted  
 OUTPut[1|2]:POLarity?

Inverts waveform relative to the offset voltage.

Parameter	Typical Return
NORMAl INVerted Default NORMAl	NORM or INV
Set output polarity to INVerted: OUTP:POL INV	

**Remarks**

- **NORMAl**: waveform goes in one direction at the beginning of the cycle;  
**INVerted**: waveform goes in other.
- As shown below, the waveform is inverted relative to the offset voltage. The offset voltage remains unchanged when the waveform is inverted.

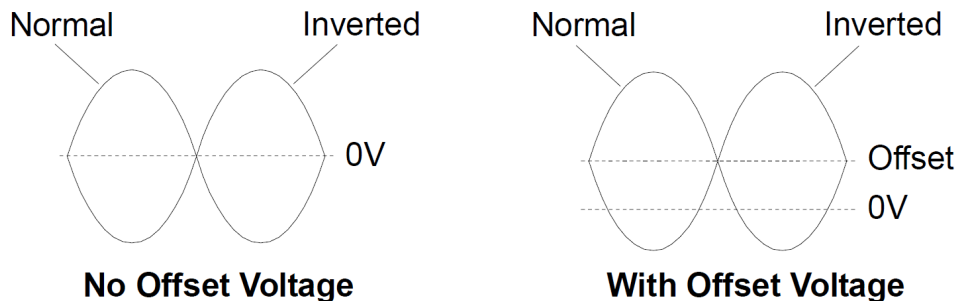

- The **Sync** signal associated with an inverted waveform is not inverted.

OUTPut:SYNC[:STATe] ON|1|OFF|0  
OUTPut:SYNC[:STATe]?

Disables or enables the front panel **Sync** connector.

Parameter	Typical Return
ON 1 OFF 0 Default ON	0 (OFF) or 1 (ON)
Disable front panel <b>Sync</b> connector: OUTP:SYNC OFF	

#### Remarks

- Disabling the **Sync** signal reduces output distortion at lower amplitudes.
- When **Sync** is disabled, the output level on the **Sync** connector is a logic "low."
- Inverting a waveform (**OUTPut[1|2]:POLarity INV**) does not invert the **Sync** signal.



OUTPut[1|2]:SYNC:MODE NORMAl|CARRier|MARKer  
 OUTPut[1|2]:SYNC:MODE?

Specifies normal **Sync** behavior (NORMAl), forces **Sync** to follow the carrier waveform (CARRier), or indicates marker position (MARKer).

Parameter	Typical Return
NORMAl CARRier MARKer Default NORMAl	NORM, CARR, or MARK
Set output sync mode to CARRier: OUTPut:SYNC:MODE CARR	

**Remarks**

- The following table details the command's behavior:

<mode>	Sync Behavior	Conditions
NORMAl	Sync follows envelope of burst signal.	When BURSt is on
	Sync follows envelope of sweep signal.	When SWEep is on
	Sync follows modulating signal.	When modulating and modulation source is internal
	Sync follows FUNC signal.	All other conditions
CARRier	Sync follows current SOURce:MARKer-:POINt setting.	When BURSt or SWEep is on and FUNC is ARB
	Sync follows FUNC signal while burst is on.	When BURSt is on and FUNC is not ARB
	Sync follows FUNC signal.	All other conditions
MARKer	Sync follows current SOURce:MARKer-:POINt setting.	When in CW mode and FUNC is ARB  When modulating, modulation source is internal, and FUNC is ARB or <modulation>:INT:FUNC is ARB
	Sync follows current SOURce:MARKer-:CYCLe setting.	When BURST is on
	Sync follows current SOURce:MARKer-:FREQuency setting.	When SWEEP is on
	Sync follows modulating signal.	When modulating, modulation source is internal, FUNC is not ARB, and INT:FUNC is not ARB
	Sync follows FUNC signal.	All other conditions

OUTPut[1|2]:SYNC:POLarity NORMal|INVerted  
OUTPut[1|2]:SYNC:POLarity?

Sets the desired output polarity of the **Sync** output to trigger external equipment that may require falling or rising edge triggers.

Parameter	Typical Return
NORMal INVerted Default NORMal	NORM or INV

Set the instrument's output sync connector to normal behavior:  
OUTP:SYNC:POL NORM

#### Remarks

- **NORMal**: voltage on **Sync** output connector is near zero, and rises when a **Sync** event occurs. Voltage stays high (approximately 3.3 V into high impedance) until **Sync** signal is de-asserted, when it falls back to near zero.
- **INVerted**: opposite of NORMal.
- The **Sync** signal may be derived from either channel in a two-channel instrument (**OUTPut:SYNC:SOURce**), and from several operating modes of the **Sync** signal (**OUTPut:SYNC:MODE**).

OUTPut:SYNC:SOURce CH1|CH2  
OUTPut:SYNC:SOURce?

Sets the source for the **Sync** output connector.

Parameter	Typical Return
CH1 CH2 Default CH1	CH1 or CH2

Set sync source to channel 2:  
OUTP :SYNC:SOUR CH2

OUTPut:TRIGger[:STATe] ON|1|OFF|0  
OUTPut:TRIGger[:STATe]?

Disables or enables the "trigger out" signal for sweep and burst modes.

Parameter	Typical Return
ON 1 OFF 0 Default OFF	0 (OFF) or 1 (ON)
Enable trigger out signal: OUTP:TRIG ON	

#### Remarks

- When enabled, a pulse with the specified edge direction (**OUTPut:TRIGger:SLOPe**) is output from the front-panel **Ext Trig** connector at the beginning of the burst or sweep.
- In triggered burst mode:
  - With **TRIGger[1|2]:SOURce IMMEDIATE**, instrument outputs square wave with 50% duty cycle from the **Ext Trig** connector. The waveform period equals the burst period (**BURSt:INTernal:PERiod**).
  - With **TRIGger[1|2]:SOURce EXTERNAL** or **BURSt:MODE GAT**, the instrument disables "trigger out." The front-panel **Ext Trig** connector cannot be used for both operations simultaneously (an externally-triggered waveform uses the same connector to trigger sweep or burst).
  - With **TRIGger[1|2]:SOURce BUS**, the instrument outputs a pulse (>1  $\mu$ s or pulse width on the EDU33210 Series) from the **Ext Trig** connector at the beginning of each sweep or burst.
- In frequency sweep mode:
  - With **TRIGger[1|2]:SOURce IMMEDIATE**, the instrument outputs a square wave with a 50% duty cycle (the rising edge is the sweep trigger) from the **Ext Trig** connector. Waveform period equals to the sweep time (**SWEep:TIME**).
  - With **TRIGger[1|2]:SOURce EXTERNAL**, instrument disables the "trigger out" signal. The front-panel **Ext Trig** connector cannot be used for both operations simultaneously (an externally-triggered sweep uses the same connector to trigger the sweep).
  - With **TRIGger[1|2]:SOURce BUS**, the instrument outputs a pulse (>1  $\mu$ s or pulse width on the EDU33210 Series) from the **Ext Trig** connector at the beginning of each sweep or burst.

OUTPut:TRIGger:SLOPe POSitive|NEGative  
OUTPut:TRIGger:SLOPe?

Selects whether the instrument uses the rising edge or falling edge for the "trigger out" signal.

Parameter	Typical Return
POSitive NEGative Default POSitive	POS or NEG
Set trigger slope to NEGative (falling edge): OUTP:TRIG:SLOP NEG	

#### Remarks

- POSitive outputs a rising edge pulse; NEGative outputs a falling edge pulse.
- When enabled using OUTPut:TRIGger, a pulse with the specified edge direction is output from the front-panel **Trig Out** connector at the beginning of a sweep or burst.

OUTPut:TRIGger:SOURce CH1|CH2  
OUTPut:TRIGger:SOURce?

Selects the source channel used by trigger output on a two-channel instrument. The source channel determines what output signal to generate on the trigger out connector.

Parameter	Typical Return
CH1 CH2 Default CH1	CH1 or CH2
Set output trigger source to CH2: OUTP:TRIG:SOUR CH2	

#### Remarks

- In a two-channel instrument, either channel may be source channel for the trigger output.

## SOURce Subsystem

The SOURce keyword is optional in many commands that set parameters for a source or output channel.

### Example

The SOURce keyword and the channel number are optional in the **[SOURce[1|2]:]AM[:DEPT]?** query, and if it is omitted, the source defaults to channel 1. The following table shows how various forms of the query are interpreted.

Parameter	Typical Return
AM:DEPT?	returns the modulation depth of channel 1
SOUR1:AM:DEPT?	returns the modulation depth of channel 1
SOUR2:AM:DEPT?	returns the modulation depth of channel 2 (two-channel instruments only)

### Subsystems Using the Optional SOURce Keyword

Because SOURce subsystem commands are often used without the SOURce keyword, these commands are listed by their individual subsystems, below:

- AM
- APPLy
- BPSK
- BURSt
- DATA
- FM
- FREQuency
- FSKey
- FUNCTion
- LIST
- MARKer
- PHASe
- PM
- PWM
- SUM
- SWEep
- VOLTage

## Commands Using the Optional SOURce Keyword

The following commands, which are not part of any subsystem, also have the optional SOURce keyword:

- COMBine:FEED
- TRACK

## AM Subsystem

The AM subsystem allows you to add amplitude modulation (AM) to a carrier waveform.

### Example

To generate an amplitude modulation (AM) waveform:

1. **Configure carrier waveform:** Use **FUNCTION**, **FREQUENCY**, **VOLTage**, and **VOLTage:OFFSet** to specify the carrier waveform's function, frequency, amplitude, and offset.
2. **Select mode of Amplitude Modulation:** **AM:DSSC**
3. **Select modulation source (internal, CH1, or CH2):** **AM:SOURce**.
4. **Select modulating waveform:** **AM:INTernal:FUNCTION**
5. **Set modulating frequency:** **AM:INTernal:FREQUENCY**
6. **Set modulation depth:** **AM[:DEPT]h**
7. **Enable AM:** **AM:STATe:ON**

The following code produces the oscilloscope image shown below.

```
FUNCTION SQU
FREQUENCY +1.0E+04
VOLTage +1
VOLTage:OFFset 0.0
AM:SOURce INT
AM:DSSC 0
AM:DEPT h +120
AM:INTernal:FUNCTION TRI
AM:INTernal:FREQ 5E+02
AM:STATe 1
OUTPut1 1
```

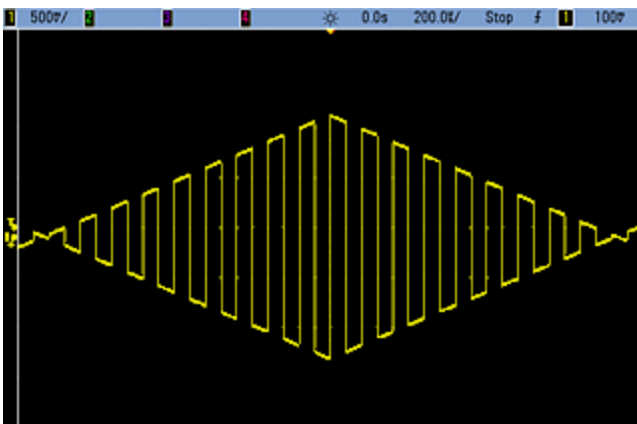

[SOURce[1|2]:]AM[:DEPT] <depth\_in\_percent>|MINimum|MAXimum|DEFault  
 [SOURce[1|2]:]AM[:DEPT]? [MINimum|MAXimum|DEFault]

Sets internal modulation depth ("percent modulation") in percent.

Parameter	Typical Return
0 to 120 Default 100	+5.000000000000000E+01

Set the internal modulation depth to 50%:

AM:DEPT 50

Set the internal modulation depth to 120%:

AM:DEPT MAX

**Remarks**

- Even at greater than 100% depth, the instrument will not exceed  $\pm 5$  V peak on the output (into a 50  $\Omega$  load). To achieve modulation depth greater than 100%, output carrier amplitude may be reduced.

[SOURce[1|2]:]AM:DSSC ON|1|OFF|0  
 [SOURce[1|2]:]AM:DSSC?

Selects Amplitude Modulation mode – Double Sideband Suppressed Carrier (ON) or AM modulated carrier with sidebands (OFF).

Parameter	Typical Return
ON 1 OFF 0	0 (OFF) or 1 (ON)

Set AM to DSSC mode:

AM:DSSC ON

**Remarks**

- The power-on default value is OFF.
- In DSSC, the **AM[:DEPT]** setting applies, and scales the modulation signal from 0 to 120% modulation.



[SOURce[1|2]:]AM:INTernal:FREQuency <frequency>|MINimum|MAXimum|DEFault  
[SOURce[1|2]:]AM:INTernal:FREQuency? MINimum|MAXimum

Sets frequency of modulating waveform. The waveform chosen as modulating source will operate at that frequency, within waveform frequency limits.

Parameter	Typical Return
1 $\mu$ Hz to the <b>maximum allowed for the internal function.</b> Default 100 Hz	+1.0000000000000000E+04
Set the modulating frequency to 10 kHz: AM:INT:FUNC 10000	

**Remarks**

- When you select an arbitrary waveform as the modulating source, the frequency changes to the frequency of the arbitrary waveform, which is based on the sample rate and the number of points in the arbitrary waveform.
- When using an arbitrary waveform for the modulating source, changing this parameter also changes the cached metadata representing the arbitrary waveform's sample rate. You can also change the modulating frequency of an arbitrary waveform with **FUNCTION:ARbitrary:FREQuency**, **FUNCTION:ARbitrary:PERiod**, and **FUNCTION:ARbitrary:SRATe**. These commands and the modulation frequency command are directly coupled in order to keep the arbitrary waveform behaving exactly as it was last played. If you later turn modulation off and select that same arbitrary waveform as the current function, its sample rate (and corresponding frequency based upon the number of points) will be the same as it was when played as the modulation source.
- If the internal function is TRiangle, UpRamp, or DnRamp, the maximum frequency is limited to 200 kHz on the EDU33210 Series. If the internal function is PRBS, the frequency refers to bit rate and is limited as **shown here**.
- This command should be used only with the internal modulation source (**AM:SOURce INTernal**).

[SOURce[1|2]:]AM:INTernal:FUNCTion <function>  
[SOURce[1|2]:]AM:INTernal:FUNCTion?

Selects shape of modulating waveform.

Parameter	Typical Return
SINusoid SQUare RAMP NRAMp TRIangle NOISe PRBS ARB Default SINusoid	SIN, SQU, RAMP, NRAM, TRI, NOIS, PRBS, or ARB
<b>View internal function waveforms.</b>	
Select a sine wave as the modulating waveform. AM:INT:FUNC SIN	

**Remarks**

- This command should be used only with the internal modulation source (**AM:SOURce INTernal**).
- Pulse and DC cannot be carrier waveform for AM.

[SOURce[1|2]:]AM:SOURce INTerna|CH1|CH2  
[SOURce[1|2]:]AM:SOURce?

Selects the source of the modulating signal.

Parameter	Typical Return
INTerna CH1 CH2 Default INTerna	INT, CH1, or CH2
Select internal modulation source: AM:SOUR INT	

#### Remarks

- A channel may not be its own modulation source.

[SOURce[1|2]:]AM:STATe ON|1|OFF|0  
[SOURce[1|2]:]AM:STATe?

Enables or disables modulation.

Parameter	Typical Return
ON 1 OFF 0 Default OFF	0 (OFF) or 1 (ON)
Enable AM: AM:STAT ON	

#### Remarks

- To avoid multiple waveform changes, enable modulation after configuring the other modulation parameters.
- Only one modulation mode may be enabled at a time.
- The instrument will not enable modulation with sweep or burst enabled. When you enable modulation, the sweep or burst mode is turned off.

#### See Also

- [BPSK Subsystem](#)
- [FM Subsystem](#)
- [FSKey Subsystem](#)
- [PM Subsystem](#)
- [PWM Subsystem](#)

## APPLY Subsystem

The APPLY subsystem allows you to configure entire waveforms with one command. The general form of an APPLY command is shown below:

```
[SOURce[1|2]:]APPLY:<function> [<frequency> [,<amplitude> [,<offset>]]]
```

For example,

```
APPLY:SIN 1e4,1,0.1
```

replaces the following commands:

```
FUNCTION SIN  
FREQ 1e4  
VOLT 1  
VOLT:OFF 0.1  
OUTP ON
```

Not only is APPLY shorter, it avoids settings conflicts that occur when sending commands individually. In addition, **APPLY** performs the following operations:

- Sets trigger source to IMMEDIATE (equivalent to **TRIGGER[1|2]:SOURCE IMMEDIATE**).
- Turns off any modulation, sweep, or burst mode currently enabled and places the instrument in continuous waveform mode.
- Turns on the channel output (**OUTPUT ON**) without changing output termination setting (**OUTPUT[1|2]:LOAD**).
- Overrides the voltage autorange setting and enables autoranging (**VOLTAGE:RANGE:AUTO**).

The instrument can generate eight types of waveforms: DC voltage, gaussian noise, PRBS, pulse, ramp/triangle wave, sine wave, square wave and arbitrary (user) waveform. Waveform-specific settings exist in the **FUNCTION subsystem**. You can also query current output configuration (**APPLY?**).

### General Remarks

#### Amplitude

- Changing amplitude may briefly disrupt output at certain voltages due to output attenuator switching. The amplitude is controlled, however, so the output voltage will never exceed the current setting while switching ranges. To prevent this disruption, disable voltage autoranging using **VOLTAGE:RANGE:AUTO OFF**. The **APPLY** command automatically enables autoranging.
- Limits Due to Output Termination: The offset range depends on the output termination setting. For example, if you set offset to 100 mVDC and then change output termination from 50  $\Omega$  to "high impedance," the offset voltage displayed on the front panel doubles to 200 mVDC (no error is generated). If you change from "high impedance" to 50  $\Omega$ , the displayed offset voltage will be halved. See **OUTPUT[1|2]:LOAD** for details.
- Limits Due to Unit Selection: The amplitude limits are determined by the output units selected.
- You cannot specify output amplitude in dBm if output termination is set to high impedance. The units are automatically converted to Vpp.

## Commands and Queries

- [SOURce[1|2]:]APPLy?
- [SOURce[1|2]:]APPLy:ARBitrary
- [SOURce[1|2]:]APPLy:DC
- [SOURce[1|2]:]APPLy:NOISe
- [SOURce[1|2]:]APPLy:PRBS
- [SOURce[1|2]:]APPLy:PULSe
- [SOURce[1|2]:]APPLy:RAMP
- [SOURce[1|2]:]APPLy:SINusoid
- [SOURce[1|2]:]APPLy:SQUare
- [SOURce[1|2]:]APPLy:TRIangle

[SOURce[1|2]:]APPLY?

Queries the output configuration.

Parameter	Typical Return
(none)	"SIN +5.000000000000000E+03, +3.000000000000000E+00, -2.500000000000000E+00"
Return the configuration for a 5 kHz, 3 V sine wave with a -2.5 VDC offset.	
APPLY?	

**Remarks**

- The function, frequency, amplitude, and offset are returned as shown above. The amplitude, but not the offset, is returned as specified by **VOLTage:UNIT**.

[SOURce[1|2]:]APPLY:ARbitrary [<sample\_rate>|MINimum|MAXimum|DEFAULT [, <amplitude>|MINimum|MAXimum|DEFAULT [, <offset>|MINimum|MAXimum|DEFAULT]]]

Outputs arbitrary waveform selected by FUNCTION: ARbitrary, using the specified sample rate, amplitude, and offset.

Parameter	Typical Return
<sample_rate> from 1 $\mu$ Sa/s to 250 MSa/s Default 40 kSa/s	(none)
<amplitude> from 1 mVpp to 10 Vpp into 50 $\Omega$ , 2 mVpp to 20 Vpp into an open circuit, default 100 mVpp into 50 $\Omega$	
<offset> is the DC offset voltage (default 0), from $\pm 5$ VDC into 50 $\Omega$ , or from $\pm 10$ VDC into an open circuit.	
Output the arbitrary waveform selected using FUNCTION:ARbitrary: APPLY:ARbitrary 1 kHz, 5.0, -2.5 V	

## Remarks

### General

- Setting a sample rate when not in the ARB mode will not change the frequency. For example, if the current function is sine, setting sample rate has no effect until the function changes to ARB.
- High sample rates may affect the actual amplitude due to filter roll-off.

### Options

- See FUNCTION: ARbitrary for available arbitrary waveform options. With FUNCTION:ARbitrary, you may select a built-in arbitrary waveform or the waveform currently downloaded to volatile memory using **MMEMory** commands.

### Offset Voltage

- The relationship between offset voltage and output amplitude is shown below.  $V_{max}$  is the maximum peak voltage for the selected output termination (5 V for a 50  $\Omega$  load or 10 V for a high-impedance load).

$$|\text{Voffset}| < V_{max} - V_{pp}/2$$

If the specified offset voltage is not valid, the instrument will adjust it to the maximum DC voltage allowed with the specified amplitude. From the remote interface, a "Data out of range" error will also be generated.

- Limits Due to Output Termination: The offset range depends on the output termination setting. For example, if you set offset to 100 mVDC and then change output termination from 50  $\Omega$  to "high impedance," the offset voltage displayed on the front panel doubles to 200 mVDC (no error is generated). If you change from "high impedance" to 50  $\Omega$ , the displayed offset voltage will be halved. See **OUTPUT[1|2]:LOAD** for details.

[SOURce[1|2]:]APPLy:DC [<frequency>|MINimum|MAXimum|DEFault [, <amplitude>|MINimum|MAXimum|DEFault [, <offset>|MINimum|MAXimum|DEFault]]]

Outputs a DC voltage.

Parameter	Typical Return
<frequency> not applicable to DC function. Must be specified as a placeholder; the value is remembered when you change to a different function.	(none)
<amplitude> not applicable to DC function. Must be specified as a placeholder; the value is remembered when you change to a different function.	
<offset> is the DC offset voltage (default 0), from $\pm 5$ VDC into 50 $\Omega$ , or from $\pm 10$ VDC into an open circuit.	
Output a DC voltage of -2.5 V: APPLy:DC DEF, DEF, -2.5 V	

#### Remarks

- Limits Due to Output Termination: The offset range depends on the output termination setting. For example, if you set offset to 100 mVDC and then change output termination from 50  $\Omega$  to "high impedance," the offset voltage displayed on the front panel doubles to 200 mVDC (no error is generated). If you change from "high impedance" to 50  $\Omega$ , the displayed offset voltage will be halved. See **OUTPut[1|2]:LOAD** for details. Changing the output termination setting does not change the voltage present at the output terminals of the instrument. This only changes the displayed values on the front panel and the values queried from the remote interface. The voltage present at the instrument's output depends on the load connected to the instrument. See **OUTPut[1|2]:LOAD** for details.

[SOURce[1|2]:]APPLY:NOISe [<frequency>|MINimum|MAXimum|DEFAULT [,<amplitude>|MINimum|MAXimum|DEFAULT [,<offset>|MINimum|MAXimum|DEFAULT]]]

Outputs gaussian noise with the specified amplitude and DC offset.

Parameter	Typical Return
<frequency>	not applicable to noise function. Must be specified as a placeholder; the value is remembered when you change to a different function. (none)
<amplitude>	Desired output amplitude in Vpp, Vrms or dBm, as specified by <b>VOLTage:UNIT</b> . 1 mVpp to 10 Vpp into 50 Ω, or twice that into an open circuit.
	If specified in Vpp, the peak to peak output will actually be output very rarely, due to gaussian nature of noise.
<offset>	is the DC offset voltage (default 0), from ±5 VDC into 50 Ω, or from ±10 VDC into an open circuit.
	Output gaussian noise bounded by 3 Vpp, with -2.5 V offset: APPL:NOIS 5 KHZ, 3.0 V, -2.5 V

## Remarks

### Frequency

- If you specify a frequency, it has no effect on the noise output, but the value is remembered when you change to a different function.
- For information on changing noise bandwidth, see **FUNCTION:NOISe:BANDwidth**.

### Offset Voltage

- The relationship between offset voltage and output amplitude is shown below. Vmax is the maximum peak voltage for the selected output termination (5 V for a 50 Ω load or 10 V for a high-impedance load).

$$|V_{\text{offset}}| < V_{\text{max}} - V_{\text{pp}}/2$$

If the specified offset voltage is not valid, the instrument will adjust it to the maximum DC voltage allowed with the specified amplitude.

From the remote interface, a "Data out of range" error will also be generated.

- Limits Due to Output Termination: The offset range depends on the output termination setting. For example, if you set offset to 100 mVDC and then change output termination from 50 Ω to "high impedance," the offset voltage displayed on the front panel doubles to 200 mVDC (no error is generated). If you change from "high impedance" to 50 Ω, the displayed offset voltage will be halved. See **OUTPUT[1|2]:LOAD** for details.



[SOURce[1|2]:]APPLY:PRBS [<frequency>|MINimum|MAXimum|DEFAULT [,<amplitude>|MINimum|MAXimum|DEFAULT [,<offset>|MINimum|MAXimum|DEFAULT]]]

Outputs a pseudo-random binary sequence with the specified bit rate, amplitude and DC offset.

The default waveform is a PN7 Maximum Length Shift Register generator.

Parameter	Typical Return
<frequency> in bits/s Default 1000	(none)
<amplitude> Desired output amplitude in Vpp, Vrms or dBm, as specified by <b>VOLTage:UNIT</b> . 1 mVpp to 10 Vpp into 50 Ω, or twice that into an open circuit. Default is 100 mVpp into 50 Ω.	
<offset> is the DC offset voltage (default 0), from ±5 VDC into 50 Ω, or from ±10 VDC into an open circuit.	
Output pseudo-random bit sequence bounded by 3 Vpp, with -2.5 V offset: APPL:PRBS 5 KHZ, 3.0 V, -2.5 V	

## Remarks

### Frequency

- PRBS is generated by a Maximum Length Sequence (MLS) generator (Linear Feedback Shift Register) which may be configured to several standard configurations. Default is PN7 at 1000 bits/second.
- A PRBS waveform using polynomial PN $x$  is generated by a shift register of  $x$  bits, and the output waveform begins with  $x$  sample periods of high output. Sample period is the reciprocal of the sample rate (**FUNCTION:PRBS:BRATE**), and the channel's **Sync** pulse indicates the waveform's start. For example, if the PRBS uses PN23 with sample rate 500 Hz, the output begins with 46 ms of high output (23 x 2 ms).
- Unlike the APPLY:NOISE function, the APPLY:PRBS function operates with the **Sync** output enabled. The **Sync** function indicates the beginning of the Pseudo-random function sequence.

### Offset Voltage

- The relationship between offset voltage and output amplitude is shown below. Vmax is the maximum peak voltage for the selected output termination (5 V for a 50 Ω load or 10 V for a high-impedance load).

$$|\text{Voffset}| < V_{\text{max}} - V_{\text{pp}}/2$$

If the specified offset voltage is not valid, the instrument will adjust it to the maximum DC voltage allowed with the specified amplitude. From the remote interface, a "Data out of range" error will also be generated.

- Limits Due to Output Termination: The offset range depends on the output termination setting. For example, if you set offset to 100 mVDC and then change output termination from 50 Ω to "high impedance," the offset voltage displayed on the front panel doubles to 200 mVDC (no error is generated). If you change from "high impedance" to 50 Ω, the displayed offset voltage will be halved. See **OUTPUT[1|2]:LOAD** for details.

[SOURce[1|2]:]APPLy:PULSe [<frequency>|MINimum|MAXimum|DEFault [,<amplitude>|MINimum|MAXimum|DEFault [,<offset>|MINimum|MAXimum|DEFault]]]

Outputs a pulse wave with the specified frequency, amplitude, and DC offset. In addition, **APPLy** performs the following operations:

- Preserves either the current pulse width setting (FUNCTION:PULSe:WIDTh) or the current pulse duty cycle setting (FUNCTION:PULSe:DCYClE).
- Preserves the current transition time setting (FUNCTION:PULSe:TRANSition[:BOTH]).
- May cause instrument to override the pulse width or edge time setting to comply with the specified frequency or period (FUNCTION:PULSe:PERiod).

Parameter	Typical Return
<frequency> in Hz Default 1 kHz	(none)
<amplitude> Desired output amplitude in Vpp, Vrms or dBm, as specified by <b>VOLTage:UNIT</b> . 1 mVpp to 10 Vpp into 50 Ω, or twice that into an open circuit. Default is 100 mVpp into 50 Ω.	
<offset> is the DC offset voltage (default 0), from ±5 VDC into 50 Ω, or from ±10 VDC into an open circuit.	
Output a 5 Vpp pulse wave at 1 kHz with a -2.5 V offset: <b>APPL:PULS 1 kHz, 5.0 V, -2.5 V</b>	

#### Remarks

##### Frequency

- The APPLy command must be appropriate for the function. For example, APPL:PULS 300 MHz results in a "Data out of range" error. In that case, the frequency would be set to the instrument's **maximum frequency for a pulse**.

##### Offset Voltage

- The relationship between offset voltage and output amplitude is shown below. Vmax is the maximum peak voltage for the selected output termination (5 V for a 50 Ω load or 10 V for a high-impedance load).

$$|\text{Voffset}| < V_{\text{max}} - V_{\text{pp}}/2$$

If the specified offset voltage is not valid, the instrument will adjust it to the maximum DC voltage allowed with the specified amplitude. From the remote interface, a "Data out of range" error will also be generated.

- Limits Due to Output Termination: The offset range depends on the output termination setting. For example, if you set offset to 100 mVDC and then change output termination from 50 Ω to "high impedance," the offset voltage displayed on the front panel doubles to 200 mVDC (no error is generated). If you change from "high impedance" to 50 Ω, the displayed offset voltage will be halved. See **OUTPut[1|2]:LOAD** for details.

```
[SOURce[1|2]:]APPLy:RAMP [<frequency>|MINimum|MAXimum|DEFault [, <amplitude>|MINimum|MAXimum|DEFault [, <offset>|MINimum|MAXimum|DEFault]]]
[SOURce[1|2]:]APPLy:TRiangle [<frequency>|MINimum|MAXimum|DEFault [, <amplitude>|MINimum|MAXimum|DEFault [, <offset>|MINimum|MAXimum|DEFault]]]
```

Outputs a ramp wave or triangle wave with the specified frequency, amplitude, and DC offset. In addition, **APPLy** performs the following operations:

- APPLy:RAMP overrides the current symmetry setting (**FUNCTion:RAMP:SYMMetry**), and sets 100% symmetry for the ramp waveform.
- APPLy:TRiangle is simply a special case of APPLy:RAMP. It is equivalent to a ramp waveform with 50% symmetry.

Parameter	Typical Return
<frequency> in Hz Default 1 kHz	(none)
<amplitude> Desired output amplitude in Vpp, Vrms or dBm, as specified by <b>VOLTage:UNIT</b> . 1 mVpp to maximum allowed for the instrument model and waveform into 50 Ω, or twice that into an open circuit. Default is 100 mVpp into 50 Ω.	
<offset> is the DC offset voltage (default 0), from ±5 VDC into 50 Ω, or from ±10 VDC into an open circuit. Configure a 5 V ramp wave at 3 kHz with 0 V offset: <b>APPL:RAMP 3 KHZ, 5.0 V, 0</b>	

## Remarks

### Frequency

- The APPLy command must be appropriate for the function. For example, the command APPL:RAMP 5 MHz results in a "Data out of range" error. In that case, the frequency would be set to 200 kHz, which is the maximum for a ramp.

### Offset Voltage

- The relationship between offset voltage and output amplitude is shown below. Vmax is the maximum peak voltage for the selected output termination (5 V for a 50 Ω load or 10 V for a high-impedance load).

$$|\text{Voffset}| < V_{\text{max}} - V_{\text{pp}}/2$$

If the specified offset voltage is not valid, the instrument will adjust it to the maximum DC voltage allowed with the specified amplitude. From the remote interface, a "Data out of range" error will also be generated.

- Limits Due to Output Termination: The offset range depends on the output termination setting. For example, if you set offset to 100 mVDC and then change output termination from 50 Ω to "high impedance," the offset voltage displayed on the front panel doubles to 200 mVDC (no error is generated). If you change from "high impedance" to 50 Ω, the displayed offset voltage will be halved. See **OUTPut[1|2]:LOAD** for details.

[SOURce[1|2]:]APPLy:SINusoid [<frequency>|MINimum|MAXimum|DEFault [,<amplitude>|MINimum|MAXimum|DEFault [,<offset>|MINimum|MAXimum|DEFault]]]

Outputs a sine wave with the specified frequency, amplitude, and DC offset.

Parameter	Typical Return
<frequency> from 1 μHz to instrument's <b>maximum frequency</b> . Default 1 kHz.	(none)
<amplitude> Desired output amplitude in Vpp, Vrms or dBm, as specified by <b>VOLTage:UNIT</b> . 1 mVpp to maximum allowed for the instrument model and waveform into 50 Ω, or twice that into an open circuit. Default is 100 mVpp into 50 Ω.	
<offset> is the DC offset voltage (default 0), from ±5 VDC into 50 Ω, or from ±10 VDC into an open circuit. Output 3 Vpp sine wave at 5 kHz with -2.5 V offset. APPL:SIN 5 KHZ, 3.0 VPP, -2.5 V	

## Remarks

### Offset Voltage

- The relationship between offset voltage and output amplitude is shown below. Vmax is the maximum peak voltage for the selected output termination (5 V for a 50 Ω load or 10 V for a high-impedance load).

$$|\text{Voffset}| < V_{\text{max}} - V_{\text{pp}}/2$$

If the specified offset voltage is not valid, the instrument will adjust it to the maximum DC voltage allowed with the specified amplitude. From the remote interface, a "Data out of range" error will also be generated.

- Limits Due to Output Termination: The offset range depends on the output termination setting. For example, if you set offset to 100 mVDC and then change output termination from 50 Ω to "high impedance," the offset voltage displayed on the front panel doubles to 200 mVDC (no error is generated). If you change from "high impedance" to 50 Ω, the displayed offset voltage will be halved. See **OUTPut[1|2]:LOAD** for details.

[SOURce[1|2]:]APPLy:SQUare [<frequency>|MINimum|MAXimum|DEFAULT [, <amplitude>|MINimum|MAXimum|DEFAULT [, <offset>|MINimum|MAXimum|DEFAULT]]]

Outputs a square wave with the specified frequency, amplitude, and DC offset. In addition, **APPLy:SQUare** overrides the current duty cycle setting (FUNCTion:SQUare:DCYCLe), and sets a 50% duty cycle for the square wave.

Parameter	Typical Return
<frequency> from 1 μHz to instrument's <b>maximum frequency</b> . Default 1 kHz.	(none)
<amplitude> Desired output amplitude in Vpp, Vrms or dBm, as specified by <b>VOLTage:UNIT</b> .  1 mVpp to maximum allowed for the instrument model and waveform into 50 Ω, or twice that into an open circuit. Default is 100 mVpp into 50 Ω.	
<offset> is the DC offset voltage (default 0), from ±5 VDC into 50 Ω, or from ±10 VDC into an open circuit.  Output 3 V square wave at 5 kHz with -2.5 V offset: APPL:SQU 5 KHZ, 3.0 V, -2.5 V	

#### Remarks

##### Frequency

- The APPLy command must be appropriate for the function. For example, APPL:SQU 40 MHz results in a "Data out of range" error and the instrument sets the frequency to its **maximum frequency for a square wave**.

##### Offset Voltage

- The relationship between offset voltage and output amplitude is shown below. Vmax is the maximum peak voltage for the selected output termination (5 V for a 50 Ω load or 10 V for a high-impedance load).

$$|\text{Voffset}| < V_{\text{max}} - V_{\text{pp}}/2$$

If the specified offset voltage is not valid, the instrument will adjust it to the maximum DC voltage allowed with the specified amplitude. From the remote interface, a "Data out of range" error will also be generated.

- Limits Due to Output Termination: The offset range depends on the output termination setting. For example, if you set offset to 100 mVDC and then change output termination from 50 Ω to "high impedance," the offset voltage displayed on the front panel doubles to 200 mVDC (no error is generated). If you change from "high impedance" to 50 Ω, the displayed offset voltage will be halved. See **OUTPut[1|2]:LOAD** for details.

## BPSK Subsystem

The BPSK subsystem allows you to modulate a waveform with Binary Phase Shift Keying (BPSK), a digital modulation format. In BPSK, the carrier waveform is phase shifted between two phase settings using an on/off keying. The source may be internal, using a square wave at a specified frequency, or external, using the external trigger input.

If the carrier function is an arbitrary waveform, then the phase shift only affects the position of sample transitions. This is different than shifting the phase of the overall arbitrary waveform.

### Example

To generate a BPSK waveform:

1. **Configure carrier waveform:** Use **FUNCTION**, **FREQUENCY**, **VOLTage**, and **VOLTage:OFFSet** to specify the carrier waveform's function, frequency, amplitude, and offset.
2. **Select modulation source (internal, or external):** **BPSK:SOURce**.
3. **Select BPSK phase:** **BPSK[:PHASe]**
4. **Set BPSK rate:** **BPSK:INTernal:RATE**
5. **Enable BPSK Modulation:** **BPSK:STATe ON**

The following code produces the oscilloscope image shown below.

```
FUNCTION SQU
FREQUENCY +1.0E+04
VOLTage +1.0
VOLTage:OFFset 0.0
BPSK:SOURce INT
BPSK:INTernal:RATE +3000
BPSK:PHASe +90
BPSK:STATe 1
OUTPut1 1
```

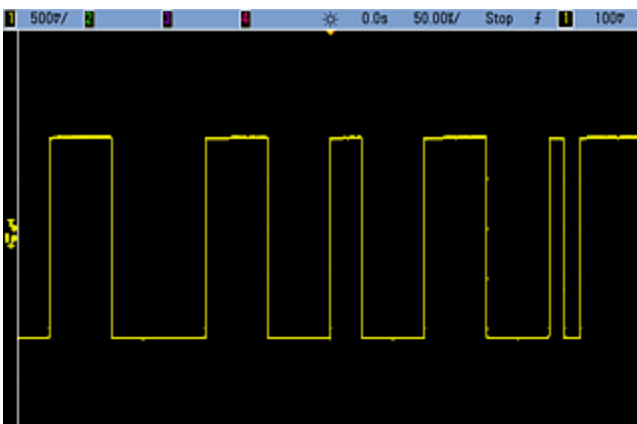

[SOURce[1|2]:]BPSK:INTernal:RATE <modulating\_frequency>|MINimum|MAXimum|DEFault  
[SOURce[1|2]:]BPSK:INTernal:RATE? [MINimum|MAXimum]

Sets the rate at which the output phase "shifts" between the carrier and offset phase.

Parameter	Typical Return
1 mHz to 1 MHz Default 10 Hz	+1.0000000000000000E-03
Set BPSK rate to 1 mHz: BPSK:INT:RATE MIN	

- The BPSK rate is used *only* when the *INTernal* source is selected (**BPSK:SOURce INTernal**).
- The internal modulating waveform is a square wave with a 50% duty cycle.

[SOURce[1|2]:]BPSK[:PHASe] <angle>|MINimum|MAXimum|DEFault  
[SOURce[1|2]:]BPSK[:PHASe]? [MINimum|MAXimum]

Sets the Binary Phase Shift Keying phase shift in degrees.

Parameter	Typical Return
0 to +360 degrees Default 180	+1.8000000000000000E+02
Set phase shift to 90 degrees: BPSK:PHAS 90	

[SOURce[1|2]:]BPSK:SOURce INTernal|EXTernal  
[SOURce[1|2]:]BPSK:SOURce?

Selects the source of the modulating signal.

Parameter	Typical Return
INTernal EXTernal Default INTernal.	INT or EXT
Select internal modulation source: BPSK:SOUR INT	

#### Remarks

- With EXTernal source, the output phase (BPSK) is determined by the signal level on the front panel Ext Trig connector. When a logic low is present, the carrier phase is output. When a logic high is present, the phase shifted phase is output.
- The maximum external BPSK rate is 1 MHz.
- When used for BPSK, the Trig In connector does not have adjustable edge polarity and is not affected by the **TRIGger[1|2]:SLOPe** command.
- With INTernal source, the rate at which output phase (BPSK) "shifts" between the carrier phase and the alternate phase is determined by the BPSK rate (**BPSK:INTernal:RATE**).
- A channel may not be its own modulation source.



[SOURce[1|2]:]BPSK:STATe ON|1|OFF|0  
[SOURce[1|2]:]BPSK:STATe?

Enables or disables modulation.

Parameter	Typical Return
ON 1 OFF 0 Default OFF	0 (OFF) or 1 (ON)
Enable BPSK: BPSK:STAT ON	

#### Remarks

- To avoid multiple waveform changes, enable modulation after configuring the other modulation parameters.
- Only one modulation mode may be enabled at a time.
- The instrument will not enable modulation with sweep or burst enabled. When you enable modulation, the sweep or burst mode is turned off.

#### See Also

- [AM Subsystem](#)
- [FM Subsystem](#)
- [FSKey Subsystem](#)
- [PM Subsystem](#)
- [PWM Subsystem](#)

## BURSt Subsystem

This section describes the BURSt subsystem.

### Example

This summarizes the steps required to generate a burst.

1. **Configure the burst waveform:** Use **APPLY** or the equivalent **FUNCTION**, **FREQUENCY**, **VOLTage**, and **VOLTage:OFFSet** commands to select the waveform's function, frequency, amplitude, and offset. You can select a sine, square, triangle, ramp, pulse, PRBS, or arbitrary waveform (noise is allowed only in the gated burst mode and DC is not allowed). For internally-triggered bursts, the minimum frequency is 2.001 mHz. For sine and square waveforms, frequencies above 6 MHz are allowed only with an "infinite" burst count.
2. **Select the "triggered" or "gated" burst mode:** Select the triggered burst mode (called "N Cycle" on the front panel) or external gated burst mode using **BURSt:MODE**. If you are using gated mode, specify true-high or true-low logic with **BURSt:GATE:POLarity**.
3. **Set the burst count:** Set the burst count (number of cycles per burst) to any value between 1 and 100,000,000 cycles (or infinite) using the **BURSt:NCYCles** command. Used in the triggered burst mode only. In PRBS, **BURSt:NCYCles** sets the number of bits of PRBS. Each burst starts at the sequence start.
4. **Set the burst period:** Set the burst period (the interval at which internally-triggered bursts are generated) to any value from 1  $\mu$ s to 8000 seconds using **BURSt:INTernal:PERiod**. Used only in the triggered burst mode with an internal trigger source.
5. **Set the burst starting phase:** Set the starting phase of the burst from -360 to +360 degrees using **BURSt:PHASe**.
6. **Select the trigger source:** Select the trigger source using the **TRIGger[1|2]:SOURce** command. Used in the triggered burst mode only.
7. **Enable the burst mode:** After configuring the other burst parameters, enable burst mode (**BURSt:STATe ON**).

The following code produces the oscilloscope image shown below.

```
APPLY:SIN 1e5,3 VPP,0
BURS:MODE TRIG
BURS:NCYC 3
BURS:INT:PER 4.4e-5
BURS:PHAS 0
TRIG:SOUR IMM
BURS:STAT ON
OUTP 1
```

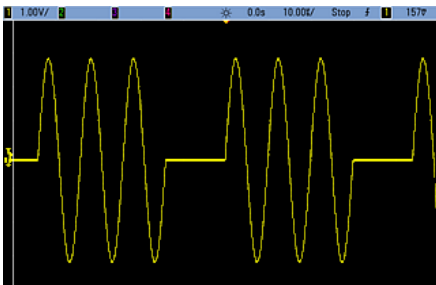

## Burst Modes

There are two burst modes, described below. The instrument enables one burst mode at a time.

- **Triggered Burst Mode (default):** The instrument outputs a waveform for a number of cycles (burst count) each time a trigger is received. After outputting the specified number of cycles, the instrument stops and waits for the next trigger. You can configure the instrument to use an internal trigger to initiate the burst or you can provide an external trigger by pressing the front panel **[Trigger]** key, by applying a trigger signal to the front-panel **Ext Trig** connector, or by sending a software trigger command from the remote interface.
- **External Gated Burst Mode:** The instrument output is either "on" or "off" based on the level of the external signal applied to the front-panel **Ext Trig** connector. When this signal is true, the instrument outputs a continuous waveform. When this signal goes false, the current waveform cycle is completed and then the instrument stops while remaining at the voltage corresponding to the starting burst phase of the waveform.

The following table shows which modes are associated with which burst features.

	Burst Mode <b>BURSt:MODE</b>	Burst Count <b>BURSt:NCYCles</b>	Burst Period <b>BURSt:INTernal:PERiod</b>	Burst Phase <b>BURSt:PHASe</b>	Trigger Source <b>TRIGger [1 2]:SOURce</b>
<b>Triggered Burst Mode:</b> Internal Trigger	TRIGgered	Available	Available	Available	IMMediate
<b>Triggered Burst Mode:</b> External Trigger	TRIGgered	Available	Not Used	Available	EXTernal, BUS
<b>Gated Burst Mode:</b> External Trigger	GATed	Not Used	Not Used	Available	Not Used

The difference between gated burst and gated output is that gated burst synchronously starts and stops using full waveform cycles, where gated output asynchronously turns instrument output on or off with an external trigger, independent of the waveform phase.

### NOTE

If the duty cycle is changed on a triggered burst square wave with the trigger mode set to Timer, the current burst will finish and one more burst will be executed before the duty cycle of the burst changes.

[SOURce[1|2]:]BURSt:GATE:POLarity NORMal|INVerted  
[SOURce[1|2]:]BURSt:GATE:POLarity?

Selects true-high (NORMal) or true-low (INVerted) logic levels on the front-panel **Ext Trig** connector for an externally gated burst.

Parameter	Typical Return
NORMal INVerted Default NORMal	NORM or INV
Select true-low logic for an externally gated burst: BURSt:GATE:POL INV	

[SOURce[1|2]:]BURSt:INTernal:PERiod <seconds>|MINimum|MAXimum|DEFault  
[SOURce[1|2]:]BURSt:INTernal:PERiod? [MINimum|MAXimum]

Sets the burst period for internally-triggered bursts.

Parameter	Typical Return
1 μs to 8000 s, default 10 ms	+1.2000000000000000E+01
Sets the burst period to 12 seconds: BURSt:INT:PER 12	

**Remarks**

- The burst period is the time between the starts of consecutive bursts.
- This is used only when IMMEDIATE triggering is enabled (TRIGger[1|2]:SOURce IMMEDIATE). It is ignored when manual or external triggering is enabled (or with gated burst mode).
- On the EDU33210 Series, burst period must satisfy the following formula:  

$$\text{Burst Period} \geq (\text{Burst Count} / \text{Waveform Frequency}) + 1 \mu\text{s}.$$
- If the burst period is too short, the instrument will increase it as needed to continuously re-trigger the burst. From the remote interface, a "Settings conflict" error will also be generated.

[SOURce[1|2]:]BURSt:MODE TRIGgered|GATed  
[SOURce[1|2]:]BURSt:MODE?

Selects the burst mode.

Parameter	Typical Return
TRIGgered GATed Default TRIGgered	TRIG or GAT
Set gated burst mode BURSt:MODE GATED	

#### Remarks

- TRIGgered: the instrument outputs a waveform for a number of cycles (burst count) each time a trigger is received from the trigger source (TRIGger[1|2]:SOURce).
- In GATed burst mode, the output waveform is on or off, based on the signal at the front-panel **Ext Trig** connector. Select this signal's polarity using **BURSt:GATE:POLarity**. When the gate signal is true, the instrument outputs a continuous waveform. When the gate signal goes false, the current waveform cycle is completed and the instrument stops and remains at the voltage level corresponding to the waveform's starting burst phase. For a noise waveform, the output stops immediately when the gate signal goes false.
- GATed: burst count, burst period, and trigger source are ignored (these are used for the triggered burst mode only). If a manual trigger is received (TRIGger[1|2]), it is ignored and no error will be generated.

[SOURCE[1|2]:]BURSt:NCYCles <num\_cycles>|INFinity|MINimum|MAXimum  
 [SOURCE[1|2]:]BURSt:NCYCles? [MINimum|MAXimum]

Sets the number of cycles to be output per burst (triggered burst mode only).

Parameter	Typical Return
Whole number from 1 (default) to 100,000,000, limited as described below	+5.000000000000000E+01
Return number of cycles per burst: BURS:NCYC 50	

**Remarks**

- With **TRIGger[1|2]:SOURCE IMMEDIATE**, burst count must be less than the product of the maximum burst period (8000 s) and the waveform frequency, as shown below.

$$\text{Burst Count} < (\text{Maximum Burst Period})(\text{Waveform Frequency})$$

- The increase the burst period up to its maximum value to accommodate the burst count (but the waveform frequency will not be changed). From the remote interface, a "Settings conflict" error will also be generated.
- When gated burst mode is selected, the burst count is ignored. However, if you change the burst count while in the gated mode, the instrument remembers the new count and used it when the triggered mode is selected.

[SOURce[1|2]:]BURSt:PHASe <angle>|MINimum|MAXimum|DEFault  
[SOURce[1|2]:]BURSt:PHASe? [MINimum|MAXimum]

Sets the starting phase angle for the burst.

Parameter	Typical Return
-360 to +360 degrees, $-2\pi$ to $+2\pi$ radians, or -(period) to +(period), as specified by <b>UNIT:ANGLE</b> . Default 0.	+6.0000000000000E+01
Set starting burst phase to 60 degrees: UNIT:ANGLE DEG BURS:PHAS 60	

**Remarks**

- Note that BURSt:PHASe is used instead of output phase, and when burst is enabled, the output phase is set to 0.
- For sine, square, and ramp, 0 degrees is the point at which the waveform crosses 0 V (or DC offset) in a positive-going direction. For arbitrary waveforms, 0 degrees is the first waveform point. Start phase has no effect on noise.
- For arbitrary waveforms on the EDU33210 Series, BURSt:PHASe is only available if the waveform is 1,000,000 points or less.
- Start phase also used in gated burst mode. When the gate signal goes false, the current waveform cycle finishes, and output remains at the voltage level of the starting burst phase.

[SOURce[1|2]:]BURSt:STATe ON|1|OFF|0  
[SOURce[1|2]:]BURSt:STATe?

Enables or disables burst mode.

Parameter	Typical Return
ON 1 OFF 0 Default OFF	0 (OFF) or 1 (ON)
Enable burst mode: BURS:STAT ON	

**Remarks**

- Output phase is set to 0 when burst is enabled.
- To avoid multiple waveform changes, enable the burst mode after configuring the other burst parameters.
- The instrument will not allow the burst mode to be enabled at the same time that sweep or any modulation mode is enabled. When you enable burst, the sweep or modulation mode is turned off.

## COMBine:FEED

[SOURce[1|2]:]COMBine:FEED CH1|CH2|NONE  
[SOURce[1|2]:]COMBine:FEED?

Enables or disables the combining of both channels' outputs on a two-channel instrument into a single channel connector. The "SOURce" keyword (default, SOURce1) specifies the base channel, and <source> specifies the channel to be combined with the base channel.

Parameter	Typical Return
CH1 CH2 NONE Default NONE	CH1, CH2, or NONE
Set the COMBine:FEED source for base Channel 1 to be Channel 2: COMB:FEED CH2	

### Remarks

- COMBine:FEED allows digital data from both channels to be added together to create the output signal on the output DAC for the base channel.
- Only one channel may operate in COMBine:FEED mode at a time
- Unlike the Modulation and **SUM** commands, COMBine:FEED can add two modulated signals.
- COMBine:FEED can generate quadrature modulated signals from the two channels to be added together into a single connector.
- To use COMBine:FEED, first configure all parameters on the individual channels.
- The signals to be combined may have a fixed phase offset between the channels.
- You can use COMBine:FEED to add noise from a second channel to a modulated signal on the base channel.
- If COMBine:FEED would cause the combined output to exceed either the instrument's output rating or the programmed limits, the instrument will set COMBine:FEED to NONE and report a settings conflict error.
- Signals are combined in digital form. When two signals of significantly different amplitudes are combined, the lower amplitude signal may have reduced resolution proportional to the ratio of the two amplitudes.
- Changing the function amplitude or sum amplitude of the master or combined channel will not change the amplitude or offset of any other function or channel. If changing the function amplitude or sum amplitude of the master or combined channel would result in exceeding either the output rating or the programmed limits, the amplitude value will be clipped and a settings conflict error will be reported.
- Changing the channel offset of the master or combined channel will not change the amplitude or offset of any other function or channel. If changing channel offset of the master or combined channel would result in exceeding either the output rating or the programmed limits, the amplitude value will be clipped and the instrument will report a settings conflict error.



- If turning limits on or adjusting programmed limits would result in a limit being lower than a signal maximum or higher than a signal minimum, the limits will not be turned on or adjusted, and the instrument will report a settings conflict error.

## DATA Subsystem

The DATA subsystem manages user-defined arbitrary waveforms:

- **[SOURce[1|2]:]DATA:ARbitrary2:FORMat AAB|ABAB** - specifies the order for bytes in a dual arbitrary waveform file
- **[SOURce[1|2]:]DATA:ARbitrary[1|2] <arb\_name>, <binary\_block>|<value>{, <value>}** - downloads arbitrary waveform normalized values to waveform memory
- **[SOURce[1|2]:]DATA:ARbitrary[1|2]:DAC <arb\_name>, <binary\_block>|<value>{, <value>}** - downloads arbitrary waveform DAC codes to waveform memory
- **[SOURce[1|2]:]DATA:ATTRibute:AVERage? [<arb\_name>]** - returns arithmetic average of all data points for an arbitrary waveform
- **[SOURce[1|2]:]DATA:ATTRibute:CFACTOR? [<arb\_name>]** - returns crest factor of all data points in an arbitrary waveform
- **[SOURce[1|2]:]DATA:ATTRibute:POINTS? [<arb\_name>]** - returns number of data points for arbitrary waveform
- **[SOURce[1|2]:]DATA:ATTRibute:PTPeak? [<arb\_name>]** - returns peak-to-peak value of all data points in an arbitrary waveform
- **[SOURce[1|2]:]DATA:VOLatile:CATalog?** - returns the contents of volatile waveform memory, including arbitrary waveforms
- **[SOURce[1|2]:]DATA:VOLatile:CLEar** - clears volatile waveform memory
- **[SOURce[1|2]:]DATA:VOLatile:FREE?** - returns number of points available (free) in volatile memory

### Format for <arb\_name>

Many DATA commands use the name of an arbitrary waveform. The following rules apply:

- <arb\_name> must match:
  - A waveform already loaded into waveform memory
  - A waveform existing for for built-in arbitrary or USB mass memory
- See **MMEMory:LOAD:DATA[1|2]**, **DATA:ARbitrary**, or **DATA:ARbitrary:DAC** for valid formats for <arb\_name>.

[SOURce[1|2]:]DATA:ARBitrary2:FORMat AAB|BAB

Specifies whether the format for data points in **DATA:ARB2** and **DATA:ARB2:DAC** commands is interleaved (ABAB) or all of channel 1 followed by all of channel 2 (AABB).

**NOTE**

You may spell out the keyword **ARBitrary2**, but you must abbreviate it as **ARB2**. You cannot abbreviate it as **ARB**.

Parameter	Typical Return
AAB BAB	AABB or ABAB

Specify an interleaved data format for dual arbitrary waveform data:  
DATA:ARB2:FORM ABAB

**Remarks**

- The **SOURce** keyword is ignored for this command.
- If you wish to have a 3 DAC count signal on channel 1 and a 4 DAC count signal on channel 2, the AABB format would dictate that the data must be sent as 3, 3, 3, 3, 3, 3, 3, 3, 4, 4, 4, 4, 4, 4, 4, 4. The ABAB format would dictate the order 3, 4, 3, 4, 3, 4, 3, 4, 3, 4, 3, 4, 3, 4, 3, 4.

[SOURCE[1|2]:]DATA:ARbitrary[1|2] <arb\_name>, <binary\_block>|<value>{, <value>}  
 [SOURCE[1|2]:]DATA:ARbitrary[1|2]:DAC <arb\_name>, <binary\_block>|<value>{, <value>}

Downloads integer values representing DAC codes (DATA:ARbitrary[1|2]:DAC) or floating point values (DATA:ARbitrary[1|2]) into waveform volatile memory as either a list of comma separated values or binary block of data. The DAC codes go from -32,768 to +32,767 on the EDU33210 Series.

**NOTE**

The optional [1|2] after the ARbitrary keyword indicates whether the data to be downloaded contains one (default) or two channels of data.

Parameter	Typical Return
<arb_name> An unquoted string of up to 12 characters.	(none)
<binary_block> integer values from -32767 to +32767 or floating point values from -1.0 to +1.0 in Definite Length Arbitrary Block format (details below). From 8 to 1024 samples per waveform, depending on <b>model</b> .  Definite-length block data allows any type of device-dependent data to be transmitted as a series of 8-bit binary data bytes. This is particularly useful for transferring large quantities of data or 8-bit extended ASCII codes.	
<value> comma separated list of integer values from -32,767 to +32,767 or floating point values from -1.0 to +1.0. From 8 to 1024 points.	
Download a comma separated list of nine waveform points into waveform memory: DATA:ARB:DAC myArb, 32767, 24576, 16384, 8192, 0, -8192, -16384, -24576, -32767	
Download nine waveform points into waveform memory as a binary block. The <PMT> specifies what terminates the binary data. It can be a Line Feed character, or the last byte of <i>your_binary_data</i> can assert the End or Identify. DATA:ARB myArb, #236<36 bytes of your_binary_data><PMT>	
Download a comma separated list of nine waveform points into waveform memory: DATA:ARB myArb, 1, .75, .50, .25, 0, -.25, -.50, -.75, -1	
Download eight waveform points of a dual arbitrary waveform into waveform memory as a comma separated list of DAC codes. There are 16 values in all, eight for each of two channels. Note that the data is interleaved (ABAB), so the positive values are all on channel 1, and the negative values are all on channel 2: DATA:ARB2:FORM ABAB DATA:ARB2:DAC myArb, 30000, -10000, 29000, -9000, 27000, -7000, 24000, -4000, 27000, -7000, 29000, -9000, 30000, -10000, 29000, -9000	
Download the same examples as above, but in AABB format: DATA:ARB2:FORM AABB DATA:ARB2:DAC myArb, 30000, 29000, 27000, 24000, 27000, 29000, 30000, 29000, -10000, -9000, -7000, -4000, -7000, -9000, -10000, -9000	

## Remarks

- Each data point is either a 16-bit integer from -32,767 and +32,767 or a 32-bit floating point value from -1.0 to +1.0. Therefore, the total number of bytes is always two times or four times the number of data points in the waveform. For example, 2,000 bytes are required to download a waveform with 1,000 points as integers, but 4,000 bytes are required to download the same waveform as floating point values.
- The values -32767 and +32767 or -1.0 to +1.0 correspond to the peak values of the waveform (if the offset is 0 V). For example, if you set the output amplitude to 10 Vpp, +32767 corresponds to +5 V and -32767 corresponds to -5 V.
- Use **FORMat:BORe** to select the byte order for block mode binary transfers.
- Use **DATA:ARB2:FORMat** to specify whether dual arbitrary waveforms are interleaved or sequential (channel 1 followed by channel 2).
- Specifying a waveform that is already loaded generates a "Specified arb waveform already exists" error. Deleting an existing waveform requires clearing all of the waveform memory with **DATA:VOLatile:CLEar**.
- The total available sample size for all waveforms loaded per channel is 8 MSa for the EDU33210 Series depending on **model**. A new waveform may be limited by waveforms already loaded.

[SOURce[1|2]:]DATA:ATTRibute:AVERage? [*<arb\_name>*]

Returns the arithmetic mean of all data points for the specified arbitrary waveform segment for built-in arbitrary or USB memory, or loaded into waveform memory.

Parameter	Typical Return
<i>&lt;arb_name&gt;</i> is any valid file name. If omitted, the default <i>&lt;arb_name&gt;</i> is the arbitrary waveform currently active (selected with <b>FUNCTION:ARbitrary</b> ).	+2.47199927E-002
Return the mean of all points stored in "SINC".	
DATA:ATTR:AVER? "INT:\BuiltIn\SINC.arb"	

## Remarks

- Querying a waveform that does not exist generates a "Specified arb waveform does not exist" error.
- *<arb\_name>* can be a file name (put in memory by **MMEMory:LOAD:DATA[1|2]**) or a name generated from **DATA:ARbitrary** or **DATA:ARbitrary:DAC**.

[SOURce[1|2]:]DATA:ATTRibute:CFACtor? [<arb\_name>]

Returns the *crest factor* of all data points for the specified arbitrary waveform segment for built-in arbitrary or USB memory, or loaded into waveform memory.

Parameter	Typical Return
<arb_name> is any valid file name. If omitted, the default <arb_name> is the arbitrary waveform currently active (selected with <b>FUNCTION:ARbitrary</b> ).	+1.72513640E+000
Return crest factor of all data points stored in "NEG_RAMP". DATA:ATTR:CFAC? "INT:\BuiltIn\NEG_RAMP.arb"	

#### Remarks

- Crest factor is the ratio of the peak value to the RMS value of the waveform.
- Querying a waveform that does not exist generates a "Specified arb waveform does not exist" error.
- <arb\_name> can be a file name (put in memory by **MMEMory:LOAD:DATA[1|2]**) or a name generated from **DATA:ARbitrary** or **DATA:ARbitrary:DAC**.

[SOURce[1|2]:]DATA:ATTRibute:POINts? [<arb\_name>]

Returns the number of points in the specified arbitrary waveform segment for built-in arbitrary or USB memory, or loaded into waveform memory.

Parameter	Typical Return
<arb_name> is any valid file name. If omitted, the default <arb_name> is the arbitrary waveform currently active (selected with <b>FUNCTION:ARbitrary</b> ).	+250
Returns the number of data points in "EXP_RISE": DATA:ATTR:POIN? "INT:\BuiltIn\EXP_RISE.arb"	

#### Remarks

- <arb\_name> can be a file name (put in memory by **MMEMory:LOAD:DATA[1|2]**) or a name generated from **DATA:ARbitrary** or **DATA:ARbitrary:DAC**.

[SOURce[1|2]:]DATA:ATTRibute:PTPeak? [<arb\_name>]

Calculates the *peak-to-peak value* of all data points for the specified arbitrary waveform segment for built-in arbitrary or USB memory, or loaded into waveform memory.

Parameter	Typical Return
Any valid file name. If omitted, the default <arb_name> is the arbitrary waveform currently active (selected with <b>FUNCTION:ARbitrary</b> ).	+1.00000000E+000
Return the peak-to-peak value for "EXP_FALL": DATA:ATTR:PTP? "INT:\Builtin\EXP_FALL.arb"	

**Remarks**

- <arb\_name> must match:
  - A waveform already loaded into waveform memory
  - A waveform existing for for built-in arbitrary or USB mass memory
- See **MMEMory:LOAD:DATA[1|2]**, **DATA:ARbitrary**, or **DATA:ARbitrary:DAC** for valid formats for <arb\_name>.
- Arbitrary Waveform Limitations: For arbitrary waveforms, amplitude is limited if the waveform data points do not span the full range of the output DAC (Digital-to-Analog Converter). For example, the built-in "Sinc" waveform does not use the full range of values, so its maximum amplitude is limited to 6.087 Vpp (into 50 Ω).
- <arb\_name> can be a file name (put in memory by **MMEMory:LOAD:DATA[1|2]**) or a name generated from **DATA:ARbitrary** or **DATA:ARbitrary:DAC**.

[SOURce[1|2]:]DATA:VOLatile:CATalog?

Returns the contents of volatile waveform memory, including arbitrary waveforms.

Parameter	Typical Return
(none)	"INT:\BUILTIN\EXP_RISE.ARB","USB:\XYZ\A.ARB","USB:\XYZ\B.ARB","USB:\xyz\xyz.ARB"
Return the contents of volatile waveform memory assuming waveforms A.arb, B.arb, and C.arb were previously loaded on channel 1: DATA:VOL:CAT?	

[SOURce[1|2]:]DATA:VOLatile:CLEar

Clears waveform memory for the specified channel and reloads the default waveform.

Parameter	Typical Return
(none)	(none)
Clear contents of waveform memory on channel 1 and reload default waveform: DATA:VOL:CLE	

[SOURce[1|2]:]DATA:VOLatile:FREE?

Returns number of points available (free) in volatile memory. Each arbitrary waveform loaded into volatile memory consumes space allocated in 128-point blocks, so a waveform of 8 to 128 points consumes one such block, a waveform of 129 to 256 points consumes two blocks, and so on.

The standard instrument includes memory for 8 million points per channel for EDU33210 Series only.

Parameter	Typical Return
(none)	+382956

Return number of bytes of free volatile memory:  
DATA:VOL:FREE?



## FM Subsystem

This summarizes the steps required to generate a frequency modulation (FM) waveform.

1. **Configure carrier waveform:** Use **FUNCTION**, **FREQUENCY**, **VOLTage**, and **VOLTage:OFFSet** to specify the carrier waveform's function, frequency, amplitude, and offset.
2. **Select modulation source (internal, CH1, or CH2):** **FM:SOURce**.
3. **Select modulating waveform:** **FM:INTernal:FUNCTION**
4. **Set modulating frequency:** **FM:INTernal:FREQUENCY**
5. **Set peak frequency deviation:** **FM:DEVIation**
6. **Enable FM:** **FM:STATe:ON**

The following code produces the oscilloscope image shown below.

```
FUNCTION SQU
FREQUENCY +4.0E+05
VOLTage +1.0
VOLTage:OFFset 0.0
FM:SOURce INT
FM:DEVIation +3.5e5
FM:INTernal:FREQUENCY +5e4
FM:INTernal:FUNCTION RAMP
FM:STATe 1
OUTP 1
```

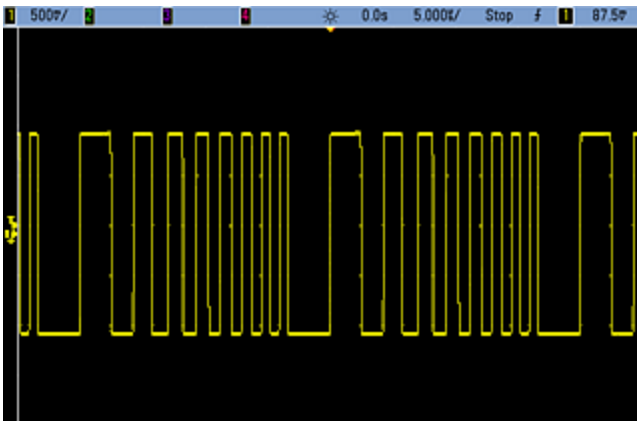

[SOURce[1|2]:]FM[:DEVIation] <peak\_deviation\_in\_Hz>|MINimum|MAXimum|DEFault  
[SOURce[1|2]:]FM[:DEVIation]? [MINimum|MAXimum]

Sets the peak frequency deviation in Hz. This value represents the peak variation in frequency of the *modulated* waveform from the carrier frequency.

Parameter	Typical Return
1 $\mu$ Hz to 15.05 (limited to 150 kHz for RAMP) Default 100 Hz	+1.000000000000000E+03
Set peak frequency deviation to 1 kHz: FM:DEV 1000	
Set peak frequency deviation to 1 $\mu$ Hz: FM:DEV MIN	

#### Remarks

- The deviation cannot exceed the carrier frequency. If you attempt to set a deviation that exceeds the carrier frequency (with FM enabled), the instrument will adjust the deviation to the maximum value allowed for that carrier frequency. *From the remote interface, a "Settings conflict" error will also be generated.*
- The carrier frequency plus the deviation cannot exceed the selected function's maximum frequency plus 100 kHz. If you attempt to set the deviation to an invalid value, the instrument adjusts it to the maximum value allowed with the present carrier frequency. The remote interface also generates a "Data out of range" error.
- If the deviation causes the carrier waveform to exceed a frequency boundary for the current duty cycle (square waveform only), the instrument will adjust the duty cycle to the maximum value allowed with the present carrier frequency. *From the remote interface, a "Settings conflict" error will also be generated.*

[SOURce[1|2]:]FM:INTernal:FREQuency <frequency>|MINimum|MAXimum|DEFAULT  
[SOURce[1|2]:]FM:INTernal:FREQuency? [MINimum|MAXimum]

Sets the frequency of the modulating waveform. The modulating source waveform operates at that frequency, within the frequency limits of that waveform.

Parameter	Typical Return
1 $\mu$ Hz to the <b>maximum allowed for the internal function</b> . Default 10 Hz	+1.0000000000000000E+04
Set the modulating frequency to 10 kHz: FM:INT:FREQ 10000	

**Remarks**

- When you select an arbitrary waveform as the modulating source, the frequency changes to the frequency of the arbitrary waveform, which is based on the sample rate and the number of points in the arbitrary waveform.
- When using an arbitrary waveform for the modulating source, changing this parameter also changes the cached metadata representing the arbitrary waveform's sample rate. You can also change the modulating frequency of an arbitrary waveform with **FUNCTION:ARbitrary:FREQuency**, **FUNCTION:ARbitrary:PERiod**, and **FUNCTION:ARbitrary:SRATe**. These commands and the modulation frequency command are directly coupled in order to keep the arbitrary waveform behaving exactly as it was last played. If you later turn modulation off and select that same arbitrary waveform as the current function, its sample rate (and corresponding frequency based upon the number of points) will be the same as it was when played as the modulation source.
- If the internal function is TRiangle, UpRamp, or DnRamp, the maximum frequency is limited to 200 kHz on the EDU33210 Series. If the internal function is PRBS, the frequency refers to bit rate and is limited as **shown here**.
- This command should be used only with the internal modulation source (**FM:SOURce INTernal**).

[SOURce[1|2]:]FM:INTernal:FUNcTION <function>  
[SOURce[1|2]:]FM:INTernal:FUNcTION?

This command selects the shape of the modulating waveform.

Parameter	Typical Return
SINusoid SQUare RAMP NRAMP TRIangle NOISe PRBS ARB Default SINusoid	SIN, SQU, RAMP, NRAM, TRI, NOIS, PRBS, or ARB
<b>View internal function waveforms.</b>	
Select a sine wave as the modulating waveform. FM:INT:FUNC SIN	

**Remarks**

- This command should be used only with the internal modulation source (FM:SOURce INTernal).
- Some combinations of carrier and internal function are not allowed: PRBS carrier and PRBS internal function, ARB carrier and ARB internal function.
- You can use noise as the modulating waveform, but you cannot use noise, pulse, or DC as the carrier.

[SOURce[1|2]:]FM:SOURce INTernal|CH1|CH2  
[SOURce[1|2]:]FM:SOURce?

Selects the source of the modulating signal.

Parameter	Typical Return
INTernal CH1 CH2 Default INTernal.	INT, CH1, or CH2
Select internal modulation source: FM:SOUR INT	

#### Remarks

- A channel may not be its own modulation source.

[SOURce[1|2]:]FM:STATe ON|1|OFF|0  
[SOURce[1|2]:]FM:STATe?

Enables or disables modulation.

Parameter	Typical Return
ON 1 OFF 0 Default OFF	0 (OFF) or 1 (ON)
Enable FM: FM:STAT ON	

#### Remarks

- To avoid multiple waveform changes, enable modulation after configuring the other modulation parameters.
- Only one modulation mode may be enabled at a time.
- The instrument will not enable modulation with sweep or burst enabled. When you enable modulation, the sweep or burst mode is turned off.

#### See Also

- [AM Subsystem](#)
- [BPSK Subsystem](#)
- [FSKey Subsystem](#)
- [PM Subsystem](#)
- [PWM Subsystem](#)

## FREQuency Subsystem

The FREQuency subsystem sets the instrument's output frequency. In two-channel instruments, the channels' frequencies may be coupled in various ways.

**FREQuency:COUPlE[:STATe] ON|OFF** enables or disables coupling, or using the ONCE, one channel's is copied to the other, but not coupled to it.

**FREQuency:COUPlE:MODE OFFSet|RATIo** specifies the frequency coupling mode.

**FREQuency:MODE** allows you to specify a frequency mode to use, including a sweep, frequency list, or fixed frequency.

### Example

The remaining FREQuency commands are used to generate a sweep, as summarized below:

1. **Select the waveform shape, amplitude and offset:** Use **APPLy** or the equivalent **FUNCTION**, **FREQuency**, **VOLTage**, and **VOLTage:OFFSet** commands to select the function, frequency, amplitude, and offset. You can select any non-arbitrary waveform.
2. **Set frequency boundaries of the sweep:** **FREQuency:START** and **FREQuency:STOP**, or **FREQuency:CENTer** and **FREQuency:SPAN**.
3. **Select sweep mode (linear or logarithmic):** **SWEEp:SPACing**
4. **Set sweep time in seconds:** **SWEEp:TIME**
5. **Select sweep trigger source:** **TRIGger[1|2]:SOURce**
6. **Set frequency at which signal on front panel Sync connector goes low during sweep (optional):** **MARKer:FREQuency**

[SOURce[1|2]:]FREQUency <frequency>|MINimum|MAXimum|DEFault  
[SOURce[1|2]:]FREQUency? [MINimum|MAXimum]

Sets the output frequency. This command is paired with **FUNCTION:PULSE:PERiod**; whichever one is executed last overrides the other.

Parameter	Typical Return
1 $\mu$ Hz to <b>maximum instrument frequency</b> . Default 1 kHz.	+1.000000000000000E+03
Set output frequency to 60 Hz: FREQ 60	

#### Remarks

- Function Limitations: The frequency limits are function dependent, as shown in the above table. If you send a command specifying a frequency that is not in the appropriate range for the current function, an error will occur. For example, if the current function is "ramp" and you send the command FREQ 20 MHZ, a "Data out of range" error is generated and the frequency is set to 200 kHz for the EDU33210 Series, which is the maximum for a ramp waveform.

[SOURce[1|2]:]FREQUency:CENTer <frequency>|MINimum|MAXimum|DEFault  
[SOURce[1|2]:]FREQUency:CENTer? [MINimum|MAXimum]

Sets the center frequency. Used with frequency span for a frequency sweep.

Parameter	Typical Return
1 $\mu$ Hz to <b>maximum instrument frequency</b> Default 550 Hz	+1.000000000000000E+03
Set sweep center frequency to 1 kHz: FREQ:CENT 1000	

#### Remarks

- The following equation shows how center frequency is limited by span frequency.  
$$\text{Center Frequency (max)} = \text{Max. Frequency for waveform} - (\text{Span}/2)$$
- The following equation shows how center frequency relates to start and stop frequencies.  
$$\text{Center Frequency} = |(\text{Stop Frequency} - \text{Start Frequency})|/2$$

[SOURce[1|2]:]FREQUency:COUPle[:STATe] ON|1|OFF|0  
[SOURce[1|2]:]FREQUency:COUPle[:STATe]?

Enables/disables frequency coupling between channels in a two-channel instrument.

Parameter	Typical Return
ON 1 OFF 0 Default OFF	0 (OFF) or 1 (ON)
Turn on the frequency couple state: FREQ:COUP ON	

**Remarks**

- Specifying ON starts frequency coupling as specified by **FREQUency:COUPle:MODE**.
- If the current offset or ratio, combined with the current frequency settings, would cause either frequency to exceed instrument specifications, the instrument will generate an error and the exceeded frequency will clip at its maximum or minimum value.
- If setting mode to RATIO and setting RATIO to 1.0 still exceeds the specifications of either channel (for example, channel 1 is a 3 MHz sine and channel 2 is a ramp, which cannot go that high), an error message will be generated and FREQUency:COUPle will be turned OFF.

[SOURce[1|2]:]FREQUency:COUPle:MODE OFFSet|RATio  
[SOURce[1|2]:]FREQUency:COUPle:MODE?

Sets the type of frequency coupling between frequency coupled channels; OFFSet specifies a constant frequency offset between channels; RATio specifies a constant ratio between the channels' frequencies.

Parameter	Typical Return
OFFSet RATio Default RATio with ratio 1.0	OFFS or RAT
Set frequency coupling mode to OFFSet: FREQ:COUP:MODE OFFS	

**Remarks**

- Power-on default for frequency coupling is OFF.
- Specifying SOURce1 or SOURce2 is irrelevant; either syntax sets the same coupling mode for both channels.

[SOURce[1|2]:]FREQUency:COUPle:OFFSet <frequency>|MINimum|MAXimum|DEFault  
[SOURce[1|2]:]FREQUency:COUPle:OFFSet?

Sets the offset frequency when an instrument is in frequency coupled mode OFFSet.

Parameter	Typical Return
A number between plus and minus the instrument's <b>maximum frequency for the waveform</b> Default 0.	+7.650000000000000E+05
Set frequency of channel 2 to 10.245 MHz above frequency of channel 1: FREQ:COUP:OFFS 10.245 MHZ	
Set frequency of channel 1 to 350 kHz above frequency of channel 2: SOUR2:FREQ:COUP:OFFS 350 KHZ	
Set frequency of channel 1 to 455 kHz below frequency of channel 2: SOUR2:FREQ:COUP:OFFS -455 KHZ	

#### Remarks

- The SOURce channel (SOURce1 or SOURce2) is used as the reference channel and the OFFSet is applied to the other channel. For example, suppose the instrument is in **FREQ:COUPLE:STATE ON** and in **FREQ:COUPLE:MODE OFFSET** (frequency offset mode active), and channel 1 is currently operating at 1.0 MHz. The command SOURce1:FREQUency:COUPle:OFFSet 500 will cause channel 1 to remain at 1.0 MHz, and channel 2 to be set to 1.5 MHz. As the frequency of either channel is changed, the frequency of the other channel will change to maintain the 500 kHz offset.
- If the frequency coupling would cause either channel to exceed instrument frequency specifications for the present functions, the command will result in an error, and the frequency will be set to its maximum or minimum limit for that channel.
- Frequency coupling is not valid with arbitrary waveforms, but you can couple the sample rate of arbitrary waveforms.



[SOURce[1|2]:]FREQUency:COUPlE:RATio <ratio>|MINimum|MAXimum|DEFault  
[SOURce[1|2]:]FREQUency:COUPlE:RATio? MINimum|MAXimum

Sets offset ratio between channel frequencies in frequency coupled mode RATio.

Parameter	Typical Return
0.001 to 1000 Default 1	+7.500000000000000E-01
Set frequency of channel 2 to twice the frequency of channel 1: FREQ:COUP:RAT 2.0	
Set frequency of channel 1 to 3.14 times the frequency of channel 2: SOUR2:FREQ:COUP:RAT 3.14	

**Remarks**

- The SOURce channel (SOURce1 or SOURce2) is used as the reference channel and the RATIO is applied to the other channel. For example, suppose the instrument is in **FREQUency:COUPlE ON** and **FREQUency:COUPlE:MODE RATIO**. Furthermore, suppose channel 1 is currently operating at 2 kHz, and channel 2 is at 10 kHz. The command SOURce1:FREQUency:COUPlE:RATio 2.5 will cause channel 1 to remain at 2 kHz, and Channel 2 to be set to 5 kHz. As the frequency of either channel is changed, the frequency of the other channel will change to maintain the 2.5 ratio.
- If the frequency coupling would cause either channel to exceed instrument frequency specifications for the present functions, the command will result in an error, and the frequency will be set to its maximum or minimum limit for that channel.
- Frequency coupling is not valid with arbitrary waveforms, but you can couple the sample rate of arbitrary waveforms.

[SOURce[1|2]:]FREQUency:MODE CW|LIST|SWEep|FIXed  
[SOURce[1|2]:]FREQUency:MODE?

Sets the type of frequency mode as a continuous wave at a fixed frequency (CW or FIXed), a frequency sweep (SWEep), or a frequency list (**LIST**).

Parameter	Typical Return
CW LIST SWEep FIXed Default CW	CW, LIST, SWE, or FIX
Set frequency mode to LIST: FREQ:MODE LIST	

**Remarks**

- If the mode is set to list, use **LIST:FREQUency** to specify the frequency list.

[SOURce[1|2]:]FREQUency:SPAN <frequency>|MINimum|MAXimum|DEFault  
 [SOURce[1|2]:]FREQUency:SPAN? [MINimum|MAXimum]

Sets frequency span (used in conjunction with the *center frequency*) for a frequency sweep.

Parameter	Typical Return
± instrument's <b>maximum frequency for the waveform</b> Default 900 Hz	+1.000000000000000E+02
Set sweep frequency span to 100 kHz: FREQ:SPAN 100 KHZ	

**Remarks**

- The following equation shows the limitation for the maximum frequency span:  

$$\text{Frequency Span (max)} = (\text{Max. Frequency for the chosen waveform} - \text{Center Frequency}) \times 2$$
- The following equation shows the relationship between the span and the start/stop frequencies.  

$$\text{Frequency Span} = \text{Stop Frequency} - \text{Start Frequency}$$
- To sweep up in frequency, set a positive frequency span; to sweep down, set a negative frequency span.

[SOURce[1|2]:]FREQUency:STARt <frequency>|MINimum|MAXimum|DEFault  
 [SOURce[1|2]:]FREQUency:STARt? [MINimum|MAXimum]  
 [SOURce[1|2]:]FREQUency:STOP <frequency>|MINimum|MAXimum|DEFault  
 [SOURce[1|2]:]FREQUency:STOP? [MINimum|MAXimum]

Sets the start and stop frequencies for a frequency sweep.

Parameter	Typical Return
± instrument's <b>maximum frequency for the waveform</b> Default 100 Hz	+1.000000000000000E+02
Set sweep start and stop frequency to 100 Hz and 1 kHz, respectively: FREQ:STAR 100 FREQ:STOP 1000	

## FSKey Subsystem

The FSKey subsystem configures a frequency-shift keying (FSK) waveform.

### Example

This summarizes the steps required to generate an FSK waveform.

1. Use `FUNCTION`, `FREQUENCY`, `VOLTage`, and `VOLTage:OFFSet` commands to select the function, frequency, amplitude, and offset of the carrier waveform.
2. Select modulation source (internal, or external): `FSK:SOURce`.
3. Select alternate ("hop") frequency: `FSK:FREQUENCY`
4. Set FSK rate: `FSK:INTernal:RATE`
5. Enable FSK Modulation: `FSK:STATe ON`

The following code produces the oscilloscope image shown below.

```
FUNCTION SQU
FREQUENCY +1e6
VOLTage +1.0
VOLTage:OFFset 0.0
FSKey:SOURce INT
FSKey:FREQUENCY +5e5
FSKey:INTernal:RATE +8e4
FSKey:STATe 1
OUTPut1 1
```

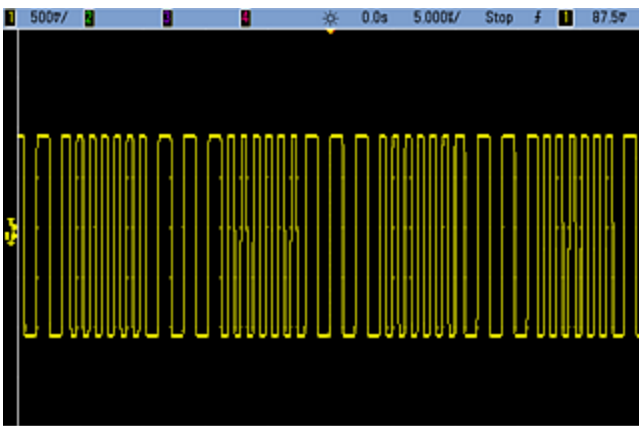

[SOURce[1|2]:]FSKey:FREQuency <frequency>|MINimum|MAXimum|DEFault  
[SOURce[1|2]:]FSKey:FREQuency? [MINimum|MAXimum]

Sets the FSK alternate (or "hop") frequency.

Parameter	Typical Return
1 $\mu$ Hz to <b>maximum instrument frequency for the waveform</b> Default 100 Hz	+1.000000000000000E-06
Set hop frequency to 10 kHz: FSK:FREQ 10000	
Set hop frequency to 1 $\mu$ Hz: FSK:FREQ MIN	

[SOURce[1|2]:]FSKey:INTernal:RATE <rate\_in\_Hz>|MINimum|MAXimum|DEFault  
[SOURce[1|2]:]FSKey:INTernal:RATE? [MINimum|MAXimum]

Sets the rate at which output frequency "shifts" between the carrier and hop frequency.

Parameter	Typical Return
0.125 mHz to 1 MHz Default 10 Hz	+1.000000000000000E+01
Set FSK rate to 10 kHz: FSK:INT:RATE 10000	
Set FSK rate to 1 mHz: FSK:INT:RATE MIN	

#### Remarks

- The FSK rate is used only with the internal source (**FSK:SOURce INTernal**).
- The modulating waveform is a square wave with a 50% duty cycle.

[SOURce[1|2]:]FSKey:SOURce INTernal|EXTernal  
[SOURce[1|2]:]FSKey:SOURce?

Selects the source of the modulating signal.

Parameter	Typical Return
INTernal EXTernal Default INTernal.	INT or EXT
Select internal modulation source: FSK:SOUR INT	

#### Remarks

- With EXTernal source, the output frequency (FSK) is determined by the signal level on the front panel Ext Trig connector. When a logic low is present, the carrier frequency is output. When a logic high is present, the hop frequency is output.
- The maximum external FSK rate is 1 MHz.
- When used for FSK, the Trig In connector does not have adjustable edge polarity and is not affected by the TRIGger[1|2]:SLOPe command.
- With INTernal source, the rate at which output frequency (FSKey) "shifts" between the frequency and the alternate frequency is determined by the FSK rate (FSKey:INTernal:RATE).
- A channel may not be its own modulation source.

[SOURce[1|2]:]FSKey:STATe ON|1|OFF|0  
[SOURce[1|2]:]FSKey:STATe?

Enables or disables modulation.

Parameter	Typical Return
ON 1 OFF 0 Default OFF	0 (OFF) or 1 (ON)
Enable FSK: FSK:STAT ON	

#### Remarks

- To avoid multiple waveform changes, enable modulation after configuring the other modulation parameters.
- Only one modulation mode may be enabled at a time.
- The instrument will not enable modulation with sweep or burst enabled. When you enable modulation, the sweep or burst mode is turned off.

#### See Also

- [AM Subsystem](#)
- [BPSK Subsystem](#)
- [FM Subsystem](#)
- [PM Subsystem](#)
- [PWM Subsystem](#)

## FUNCTION Subsystem

The FUNCTION subsystem configures the instrument's output function:

- [SOURCE[1|2]:]FUNCTION <function> - output waveform
- [SOURCE[1|2]:]FUNCTION:ARbitrary <filename> - arbitrary waveform (.arb) that has previously been loaded into volatile memory with MMEMory:LOAD:DATA[1|2].
- [SOURCE[1|2]:]FUNCTION:ARbitrary:ADVance TRIGger|SRATe - method for advancing to next arbitrary waveform data point.
- [SOURCE[1|2]:]FUNCTION:ARbitrary:FILTer NORMAl|STEP|OFF - filter for arbitrary waveform
- [SOURCE[1|2]:]FUNCTION:ARbitrary:FREQUency <frequency>|MINimum|MAXimum|DEFault - frequency of arbitrary waveform
- [SOURCE[1|2]:]FUNCTION:ARbitrary:PERiod <period>|MINimum|MAXimum|DEFault - period of arbitrary waveform
- [SOURCE[1|2]:]FUNCTION:ARbitrary:POINts? - number of points (samples) in the current arbitrary waveform
- [SOURCE[1|2]:]FUNCTION:ARbitrary:PTPeak <voltage>|MINimum|MAXimum|DEFault - peak-to-peak voltage for an arbitrary waveform
- [SOURCE[1|2]:]FUNCTION:ARbitrary:SRATe <sample\_rate>|MINimum|MAXimum|DEFault - sample rate for arbitrary waveform
- [SOURCE[1|2]:]FUNCTION:ARbitrary:SYNChronize - restarts arbitrary waveforms at first sample simultaneously on both waveforms
- [SOURCE[1|2]:]FUNCTION:NOISe:BANDwidth|BWIDth <bandwidth>|MINimum|MAXimum|DEFault - bandwidth for NOISe waveform
- [SOURCE[1|2]:]FUNCTION:PRBS:BRATe <bit\_rate>|MINimum|MAXimum|DEFault - bit rate for pseudo-random binary sequence (PRBS)
- [SOURCE[1|2]:]FUNCTION:PRBS:DATA <sequence\_type> - sequence type for PRBS
- [SOURCE[1|2]:]FUNCTION:PRBS:TRANSition[:BOTH] <seconds>|MINimum|MAXimum|DEFault - edge transition time for both edges of PRBS
- [SOURCE[1|2]:]FUNCTION:PULSe:DCYClE <percent>|MINimum|MAXimum|DEFault - pulse duty cycle for pulse
- [SOURCE[1|2]:]FUNCTION:PULSe:HOLD WIDTH|DCYClE - whether pulse width or duty cycle is held constant as other parameters vary
- [SOURCE[1|2]:]FUNCTION:PULSe:PERiod <seconds>|MINimum|MAXimum|DEFault - period for a pulse
- [SOURCE[1|2]:]FUNCTION:PULSe:TRANSition:LEADing <seconds>|MINimum|MAXimum|DEFault
- [SOURCE[1|2]:]FUNCTION:PULSe:TRANSition:TRAILing <seconds>|MINimum|MAXimum|DEFault
- [SOURCE[1|2]:]FUNCTION:PULSe:TRANSition[:BOTH] <seconds>|MINimum|MAXimum|DEFault - edge time for pulse
- [SOURCE[1|2]:]FUNCTION:PULSe:WIDTh <seconds>|MINimum|MAXimum|DEFault - pulse width

- `[SOURCE[1|2]:]FUNCTION:RAMP:SYMMetry <percent>|MINimum|MAXimum|DEFAULT` - symmetry percentage for ramp
- `[SOURCE[1|2]:]FUNCTION:SQUare:DCYCLE <percent>|MINimum|MAXimum|DEFAULT` - duty cycle percentage for square
- `[SOURCE[1|2]:]FUNCTION:SQUare:PERiod <seconds>|MINimum|MAXimum|DEFAULT` - period for square

`[SOURCE[1|2]:]FUNCTION <function>`  
`[SOURCE[1|2]:]FUNCTION?`

Selects the output function.

Parameter	Typical Return
SINusoid SQUare TRIangle RAMP PULSe PRBS NOISe ARB DC Default SINusoid	SIN, SQU, TRI, RAMP, PULS, PRBS, NOIS, ARB, or DC
Set output on channel 2 to sine: <code>SOUR2:FUNC SIN</code>	

#### Remarks

- The selected waveform (other than an arbitrary waveform) is output using the previously selected frequency, amplitude, and offset voltage settings. Arbitrary waveforms are played according to the settings specified in the arbitrary waveform file. Brand new arbitrary waveforms inherit the current arbitrary waveform settings.
- NOISe generates white gaussian noise with adjustable bandwidth and crest factor about 3.5.
- PRBS generates pseudo-random noise using Linear Feedback Shift Register (LFSR) user selectable methods.
- ARB generates the arbitrary waveform currently selected by `FUNCTION:ARbitrary`.
- Function Limitations: If you change to a function whose maximum frequency is less than that of the current function, the frequency is adjusted to the maximum for the new function. For example, if you change a high frequency sine wave to the ramp function, the instrument will adjust the output frequency to 200 kHz (the upper limit for ramps)From the remote interface, a "Settings conflict" error will also be generated.
- Amplitude Limitations: If you change to a function whose maximum amplitude is less than that of the current function, the amplitude is adjusted to the maximum for the new function. This may occur when the output units are *Vrms* or *dBm* due to the differences in crest factor for the various output functions For example, if you change a 5 *Vrms* square wave (into 50  $\Omega$ ) to a sine wave, the instrument will adjust the amplitude to 3.536 *Vrms* (the upper limit for sine in *Vrms*). The remote interface will also generate a "Settings conflict" error.



[SOURce[1|2]:]FUNction:ARBitrary <filename>  
[SOURce[1|2]:]FUNction:ARBitrary?

Selects an arbitrary waveform (.arb) that has previously been loaded into volatile memory for the channel specified with **MMEMory:LOAD:DATA[1|2]** or **DATA:ARBitrary**. Several waveforms can be in volatile memory simultaneously.

Parameter	Typical Return
See MMEMory:LOAD:DATA[1 2], for valid <filename> formats.	"USB:\MyArb103.arb"
Select an arbitrary waveform in memory on channel 1: FUNC:ARB "USB:\MyArb103.arb"	
Load an arbitrary waveform into volatile memory. Then select and play the waveform: MMEM:LOAD:DATA "INT:\BUILTIN\Sinc.arb" FUNction:ARBitrary "INT:\BUILTIN\Sinc.arb" FUNction ARB	

#### Remarks

- The <filename> should match the filename used to load the arbitrary waveform into volatile memory with **MMEMory:LOAD:DATA[1|2]**, **DATA:ARBitrary**, or **DATA:ARBitrary:DAC**.
- When you store an arbitrary waveform segment (**MMEMory:STORe:DATA[1|2]**), the instrument's current settings (voltage values, sample rate, filter type, and so on) are stored in the segment file. When you play the file for the first time with **FUNction:ARBitrary**, these settings are loaded and override the instrument's current settings. If you have manually edited a segment file such that the instrument settings have been removed, the instrument settings will not be changed when you execute **FUNction:ARBitrary**.
- When you store an arbitrary waveform segment (**MMEMory:STORe:DATA[1|2]**), the instrument's current settings (voltage values, sample rate, filter type, and so on) are stored in the segment file. When you play the file for the first time with **FUNction:ARBitrary**, these settings are loaded and override the instrument's current settings. If you have manually edited a segment file such that the instrument settings have been removed, the instrument settings will not be changed when you execute **FUNction:ARBitrary**.

[SOURce[1|2]:]FUNCTION:ARBitrary:ADVance TRIGger|SRATe  
[SOURce[1|2]:]FUNCTION:ARBitrary:ADVance?

Specifies the method for advancing to the next arbitrary waveform data point for the specified channel.

Parameter	Typical Return
TRIGger SRATe Default TRIG	TRIG or SRAT
Set advance method to trigger: FUNC:ARB:ADV TRIG	

#### Remarks

- TRIGger causes instrument to advance to next data point with each trigger received and forces TRIGger [1|2]:SOURce to EXTernal.
- SRATe causes instrument to advance to next data point at the sample rate set by FUNCTION:ARBitrary:SRATe.

[SOURce[1|2]:]FUNCTION:ARBitrary:FILTer NORMal|STEP|OFF  
[SOURce[1|2]:]FUNCTION:ARBitrary:FILTer?

Specifies the filter setting for an arbitrary waveform.

Parameter	Typical Return
{NORMal STEP OFF}, default STEP	NORMal, STEP, or OFF
Set filter to NORMal: FUNCTION:ARBitrary:FILTer NORM	

#### Remarks

- **NORMal** filters the data points with the filter that provides the flattest frequency response. This effectively smoothes the signal, but sharp transitions will have preshoot and overshoot.
- **STEP** filters the data points in a way that effectively smoothes the signal while minimizing the preshoot and overshoot. However, this setting has a narrower bandwidth than the NORMal setting.
- **OFF** steps from point to point at the sample rate. Moves between data points are accomplished as quickly as possible with no smoothing. If the <mode> is set to OFF, the instrument uses a filter whose bandwidth limit restricts the maximum sample rate for the arbitrary waveform to 62.5 MSa/s or 250 MSa/s for the EDU33210 Series.
- To use this command on the EDU33210 Series, you must set FUNCTION:ARBitrary:FILTer to OFF.

[SOURce[1|2]:]FUNCTion:ARBITrary:FREQUency <frequency>|MINimum|MAXimum|DEFault  
[SOURce[1|2]:]FUNCTion:ARBITrary:FREQUency? MINimum|MAXimum  
[SOURce[1|2]:]FUNCTion:ARBITrary:PERiod <period>|MINimum|MAXimum}DEFault  
[SOURce[1|2]:]FUNCTion:ARBITrary:PERiod? MINimum|MAXimum

Sets the frequency or period for the arbitrary waveform.

Parameter	Typical Return
<frequency> (Hz): Limited by the number of waveform points. Default based on 40 kSa/s sample rate.	+1.000000000000000E+03
<period> (seconds): Limited by the number of waveform points. Default based on 40 kSa/s sample rate.	+1.000000000000000E-03
Set arbitrary waveform frequency to 1000 Hz. FUNC:ARB:FREQ 1000	

#### Remarks

- With **FUNCTion:ARBITrary:FILTer OFF**, the arbitrary waveform sample rate is limited to 1/4 of the maximum sample rate.
- The <frequency> ranges from 1 μHz to 31.25 MHz or 250 MHz on the EDU33210 Series. Frequency is also limited by the Filter setting. With **FUNCTion:ARBITrary:FILTer OFF**, the arbitrary waveform sample rate is limited to 62.5 MSa/s. Therefore, frequency is also reduced to 7.8125 MHz for an eight point waveform or one-quarter of that for a 32-point waveform.
- The arbitrary waveform sample rate and frequency are not coupled to **SOUR:FREQ**, which applies to only non-arbitrary waveforms.
- The arbitrary waveform plays at a speed specified by the sample rate. When setting the frequency or period of an arbitrary waveform, the instrument changes the sample rate based on the number of points in the waveform and the new frequency or period setting. The new frequency or period may be altered slightly to meet the restrictions of Sample Rate resolution and the number of points. In other words, frequency will be recalculated from the new sample rate and number of points to ensure compatibility between the coupled parameters. This is due to math resolution of 15 digits in combination with a sample rate that can also be 15 digits.
- Changing the number of points in the waveform, or changing the sample rate with **FUNCTion:ARBITrary:SRATe**, changes the frequency and period settings.

[SOURce[1|2]:]FUNction:ARBitrary:POINts?

Returns the number of points in the currently selected arbitrary waveform.

Parameter	Typical Return
(none)	+100000

Return the number of points in the current arbitrary waveform on channel 1:  
FUNC:ARB:POIN?

**Remarks**

- The maximum number of points depends on the instrument's memory, which is based on the **model**.

[SOURce[1|2]:]FUNCtion:ARBitrary:PTPeak <voltage>|MINimum|MAXimum|DEFault  
[SOURce[1|2]:]FUNCtion:ARBitrary:PTPeak? [MINimum|MAXimum]

Sets peak to peak voltage.

Parameter	Typical Return
10 VDC into 50 $\Omega$ , 20 VDC into an open circuit Default 100 mV	+4.000000000000000E+00
Set peak to peak voltage to 4 V: FUNC:ARBitrary:PTPeak 4	

#### Remarks

- *Limits Due to Amplitude:* You can set the voltage levels to a positive or negative value with the restrictions shown below. Vpp is the maximum peak-to-peak amplitude for the selected output termination (10 Vpp into 50  $\Omega$  or 20 Vpp into an open circuit).
$$V_{\text{high}} - V_{\text{low}} \leq V_{\text{pp}} (\text{max}) \text{ and } V_{\text{high}}, V_{\text{low}} \leq V_{\text{pp}} (\text{max})/2$$
- *Differences between remote and front panel operation:*
  - **Remote Interface:** Setting the high or low level from the remote interface can change the high level or low level to achieve the desired setting. In this case either a "Data out of range" or "Settings conflict" error will occur. If the high level is set below the low level, the instrument will set the low level 1 mV less than the high level. If the high level is set below the LOW limit or the instrument output specifications, the low level will be set to the LOW limit or instrument output specification and the high level will be set 1 mV above the low level. A similar set of rules applies if the low level is set incorrectly.
  - Similarly, the low level can be set above the high level from the remote interface. In this case the instrument will set the high level 1 mV larger than the low level. If the low level is set higher than the HIGH limit or the instrument output specifications, the high level will be set to the HIGH limit or instrument output specification and the low level will be set 1 mV below the high level.
  - **Front Panel:** Setting the high or low level from the front panel may clip that level setting in order to achieve the desired level setting, and a "Data out of range" error will be generated. The high level cannot be set below the low level from the front panel.
- Setting the high and low levels also sets the waveform amplitude and offset. For example, if you set the high level to +2 V and the low level to -3 V, the resulting amplitude is 5 Vpp, with a -500 mV offset.
- *Limits Due to Output Termination:* If you change the output termination setting, the displayed voltage levels will be adjusted (and no error will be generated). For example, if you set the high level to +100 mVDC and then change the output termination from 50  $\Omega$  to "high impedance", the amplitude displayed on the front panel will double to +200 mVDC. If you change from "high impedance" to 50  $\Omega$ , the displayed amplitude will be halved. Changing the output termination setting does not change the voltage present at the output terminals of the instrument. This only changes the displayed values on the front panel and the values queried from the remote interface. The voltage present at the instrument's output depends on the load connected to the instrument. See **OUTPut[1|2]:LOAD** for details.

- Limits due to voltage limits: If the voltage limits are enabled, the level settings are checked against the specified limits (**VOLTage:LIMit:HIGH**, **VOLTage:LIMit:LOW**) before a change in level is executed. If a change in output level would exceed a LIMIT setting, the level is clipped to the maximum (or minimum) value allowed that will not exceed the LIMit setting and a "Settings conflict" error will be generated.
- Limits due to Output Coupling: If two channels are coupled, limitations of setting the levels of both channels will be checked before a change in level is executed. In this case, if a change in level would exceed a LIMIT setting, or instrument output specifications for either channel, the level is clipped to the maximum (or minimum) allowable value and a "Settings conflict" error will be generated.
- To invert the waveform relative to the offset voltage, use **OUTPut[1|2]:POLarity**.

[SOURce[1|2]:]FUNction:ARBitrary:SRATe <sample\_rate>|MINimum|MAXimum|DEFault  
 [SOURce[1|2]:]FUNction:ARBitrary:SRATe? MINimum|MAXimum

Sets the sample rate for the arbitrary waveform.

Parameter	Typical Return
1 μSa/s to 250 MSa/s Default 40 kSa/s. Limited to 62.5 MSa/s if FUNCTION:ARBitrary:FILTer is OFF.	+1.000000000000000E+04
Set sample rate to 10 kSa/s: FUNC:ARB:SRAT 1e4	

**Remarks**

- The sample rate and frequency parameter are not coupled when playing an arbitrary waveform segment.
- Setting a sample rate when not in the ARB mode will not change the frequency. For example, if the current function is sine, setting sample rate has no effect until the function changes to ARB.
- The maximum sample rate depends on the filter applied to the arbitrary waveform. See **FUNCTION:ARBitrary:FILTer** for details.

## [SOURce[1|2]:]FUNCTION:ARbitrary:SYNChronize

Causes two independent arbitrary waveforms to synchronize to first point of each waveform (two-channel instruments only).

Parameter	Typical Return
(none)	(none)

Load an internal Haversine waveform into channel 1 and a custom waveform from a USB drive into channel 2. Set both sample rates to 100 kSa/s and then synchronize both channels to the first point of each waveform:

```
MMEM:LOAD:DATA "Int:\Builtin\HAVERSINE.arb"  
FUNC:ARB "Int:\Builtin\HAVERSINE.ARB"  
FUNC ARB  
FUNC:ARB:SRATE 1E+05  
  
MMEM:LOAD:DATA2 "USB:\MyFiles\TestDUT3.arb"  
SOUR2:FUNC:ARB "USB:\MyFiles\TestDUT3.arb"  
SOUR2:FUNC ARB  
SOUR2:FUNC:ARB:SRAT 1E+05  
  
FUNC:ARB:SYNC
```

### Remarks

- This command stops and restarts the arbitrary waveforms on both channels at whatever sample rates they happen to be set.
- If the two arbitrary waveforms have the same number of points and sample rate, they will remain synchronized over multiple repetitions; otherwise, they will only be synchronized at the beginning and after numbers of repetitions that happen to be multiples of the number of points in both waveforms. For example, if you synchronize an 8-point waveform and a 10-point waveform, they will re-synchronize after 40, 80, and 120 repetitions.
- This functionality is similar to using burst mode, but it operates in continuous wave mode.
- This command also works with burst, sweep, and modulation, when trying to synchronize two arbitrary waveforms.

[SOURce[1|2]:]FUNCTION:NOISe:BANDwidth|BWIDth <*bandwidth*>|MINimum|MAXimum|DEFault  
[SOURce[1|2]:]FUNCTION:NOISe:{BANDwidth|BWIDth}? [MINimum|MAXimum]

Sets bandwidth of noise function.

Parameter	Typical Return
1 mHz to instrument's <b>maximum frequency</b> Default 100 kHz	+6.000000000000000E+03
Set bandwidth to 20 kHz: FUNC:NOISe:BWIDth 20000	

**Remarks**

- The Noise function produces white gaussian noise with a Crest Factor of 4.6.
- The noise bandwidth is continuously adjustable to place more noise energy in the frequency range from 0 Hz to the specified noise bandwidth frequency.

[SOURce[1|2]:]FUNCTION:PRBS:BRATe <*bit\_rate*>| MINimum|MAXimum|DEFault  
[SOURce[1|2]:]FUNCTION:PRBS:BRATe? [MINimum|MAXimum]

Sets the pseudo-random binary sequence (PRBS) bit rate.

Parameter	Typical Return
1 mbit/s to maximum allowed for the instrument Default 1000 bit/s	+1.920000000000000E+04
Set bit rate to 19,200 bits per second FUNC:PRBS:BRATe 19200	

**Remarks**

- A PRBS waveform using polynomial PN<sub>x</sub> is generated by a shift register of **x** bits, and the output waveform begins with **x** sample periods of high output. Sample period is the reciprocal of the sample rate (**FUNCTION:PRBS:BRATe**), and the channel's **Sync** pulse indicates the waveform's start. For example, if the PRBS uses PN23 with sample rate 500 Hz, the output begins with 46 ms of high output (23 x 2 ms).
- The bit rate is independent of the data sequence length.



[SOURce[1|2]:]FUNCTion:PRBS:DATA <sequence\_type>  
[SOURce[1|2]:]FUNCTion:PRBS:DATA?

Sets the pseudo-random binary sequence (PRBS) type. Setting the sequence type sets the length and feedback values as shown below.

Parameter	Typical Return
PN7 PN9 PN11 PN15 PN20 PN23  Value after PN corresponds to maximum shift register length in bits. Default is PN7.	PN# (PN3 through PN9) or PN## (PN10 through PN32), where each # is one digit.
Set data format to PN23: FUNC:PRBS:DATA PN23	

**Remarks**

- SYNC output may be active during a PRBS function, unlike the **NOISe** function. The SYNC output marks the first data bit of a PRBS waveform.

- A PRBS waveform using polynomial PN $x$  is generated by a shift register of  $x$  bits, and the output waveform begins with  $x$  sample periods of high output. Sample period is the reciprocal of the sample rate (**FUNCTION:PRBS:BRATE**), and the channel's **Sync** pulse indicates the waveform's start. For example, if the PRBS uses PN23 with sample rate 500 Hz, the output begins with 46 ms of high output (23 x 2 ms). The polynomials are shown below.

Sequence Type	Polynomial	Length
PN3	$x^3 + x^2 + 1$	3
PN4	$x^4 + x^3 + 1$	4
PN5	$x^5 + x^3 + 1$	5
PN6	$x^6 + x^5 + 1$	6
PN7	$x^7 + x^6 + 1$	7
PN8	$x^8 + x^6 + x^5 + x^4 + 1$	8
PN9	$x^9 + x^5 + 1$	9
PN10	$x^{10} + x^7 + 1$	10
PN11	$x^{11} + x^9 + 1$	11
PN12	$x^{12} + x^6 + x^4 + x^1 + 1$	12
PN13	$x^{13} + x^4 + x^3 + x^1 + 1$	13
PN14	$x^{14} + x^5 + x^3 + x^1 + 1$	14
PN15	$x^{15} + x^{14} + 1$	15
PN16	$x^{16} + x^{15} + x^{13} + x^4 + 1$	16
PN17	$x^{17} + x^{14} + 1$	17
PN18	$x^{18} + x^{11} + 1$	18
PN19	$x^{19} + x^6 + x^2 + x^1 + 1$	19
PN20	$x^{20} + x^{17} + 1$	20
PN21	$x^{21} + x^{19} + 1$	21
PN22	$x^{22} + x^{21} + 1$	22
PN23	$x^{23} + x^{18} + 1$	23
PN24	$x^{24} + x^{23} + x^{22} + x^{17} + 1$	24
PN25	$x^{25} + x^{22} + 1$	25
PN26	$x^{26} + x^6 + x^2 + x^1 + 1$	26
PN27	$x^{27} + x^5 + x^2 + x^1 + 1$	27
PN28	$x^{28} + x^{25} + 1$	28
PN29	$x^{29} + x^{27} + 1$	29
PN30	$x^{30} + x^6 + x^4 + x^1 + 1$	30
PN31	$x^{31} + x^{28} + 1$	31
PN32	$x^{32} + x^{22} + x^2 + x^1 + 1$	32

[SOURce[1|2]:]FUNCtion:PRBS:TRANSition[:BOTH] <seconds>|MINimum|MAXimum|DEFault  
[SOURce[1|2]:]FUNCtion:PRBS:TRANSition[:BOTH]? [MINimum|MAXimum]

Sets PRBS transition edge time on both edges of a PRBS transition.

Parameter	Typical Return
8.4 ns (default) to 1 $\mu$ sec, limited as described below	+1.0000000000000000E-08
Set edge time to 10 ns for the leading and trailing edges (two methods):	
FUNC:PRBS:TRAN 10 ns	
FUNC:PRBS:TRAN .000000010	

**Remarks**

- The default "BOTH" keyword is optional and allows simultaneous control of the leading and trailing edges of the PRBS waveform.
- The edge time applies to both the rising and falling edges, and represents the time between the 10% and 90% thresholds of each edge.
- The specified edge time must fit within the specified period. The instrument will limit the edge time as needed to accommodate the specified bit rate. From the remote interface, a "Settings conflict" error will also be generated.

[SOURce[1|2]:]FUNCTION:PULSe:DCYClE <percent>|MINimum|MAXimum|DEFault  
[SOURce[1|2]:]FUNCTION:PULSe:DCYClE? [MINimum|MAXimum]

Sets pulse duty cycle.

Parameter	Typical Return
0 to 100, limited as described below Default 10	+5.000000000000000E+01
Set duty cycle to 50%: FUNC:PULS:DCYC 50	

#### Remarks

- The **FUNCTION:PULSe:DCYClE** and **FUNCTION:PULSe:WIDTh** commands affect the same parameter. In some applications, it is natural to adjust pulse width directly (in seconds); in others, adjusting duty cycle seems more natural. When frequency is adjusted, if pulse width was most recently adjusted as duty cycle on the front panel, then duty cycle will be kept constant as frequency or period changes. However, if pulse width was the last setting, then pulse width will be kept constant as frequency or period changes. See **FUNCTION:PULSe:HOLD**.
- The pulse duty cycle is defined as:  

$$\text{Duty Cycle} = 100 \times \text{Pulse Width} \div \text{Period}$$

Pulse width is the time from the 50% threshold of a pulse's rising edge to the 50% threshold of the next falling edge.

- The pulse duty cycle range is 0 percent to 100 percent. However, the pulse duty cycle is limited by *minimum pulse width* and *edge time* restrictions, which prevent you from setting exactly 0 percent or 100 percent. For example, for a 1 kHz pulse waveform, you are typically restricted to pulse duty cycles in the range 0.002 percent to 99.998 percent. This is limited by the minimum pulse width of 16 ns or 5 ns up to 4 Vpp and 8 ns up to 10 Vpp on the EDU33210 Series.
- Restrictions Based on Pulse Width: The specified pulse duty cycle must conform to the following restrictions determined by the *minimum pulse width*. The instrument will adjust pulse duty cycle as needed to accommodate the specified period. *From the remote interface, a "Settings conflict" error will also be generated.*

$$\begin{aligned} &\text{Duty Cycle} \geq 100(\text{Minimum Pulse Width} / \text{Period}) \\ &\text{and} \\ &\text{Duty Cycle} \leq 100 (1 - \text{Minimum Pulse Width} / \text{Period}) \end{aligned}$$

The minimum pulse width is 16 ns on the EDU33210 Series

- *Restrictions Based On and Affecting Edge Time:* The specified pulse duty cycle may affect the edge time. The edge time is adjusted first, and then the duty cycle is adjusted to accommodate the specified period, conforming to the following restriction. From the remote interface, a "Settings conflict" error will also be generated.

$$\begin{aligned} &\text{Duty Cycle} \geq [(0.8 \times \text{Leading Edge Time}) + (0.8 \times \text{Trailing Edge Time})] / \text{Period} \times 100 \\ &\text{and} \\ &\text{Duty Cycle} \leq [1 - [(0.8 \times \text{Leading Edge Time}) + (0.8 \times \text{Trailing Edge Time})] / \text{Period}] \times 100 \end{aligned}$$

[SOURce[1|2]:]FUNction:PULSe:HOLD WIDTH|DCYClE  
[SOURce[1|2]:]FUNction:PULSe:HOLD?

Sets the pulse waveform parameter (either pulse width or duty cycle) to be held constant as other parameters are varied.

Parameter	Typical Return
WIDTH DCYClE Default WIDTH	WIDT or DCYC

Set the instrument to hold duty cycle for pulse waveforms:

**FUNC:PULS:HOLD DCYC**

- **WIDTH:** the instrument holds the pulse width setting (in seconds) constant as the period is varied. If a command to set a duty cycle value is received, the duty cycle is converted to the equivalent pulse width. If pulse width modulation (PWM) is turned on, the pulse width and width deviation are held as the period is varied. Duty cycle deviation commands are converted to width deviations.

Minimum width and edge time restrictions apply. May cause a change in the selected edge times, pulse width, or both.

- **DCYClE:** the instrument holds the pulse duty cycle setting (in percent) constant as the period is varied. If a command to set a pulse width value is received, the width is converted to the equivalent duty cycle. If pulse width modulation (PWM) is turned on, the pulse duty cycle and the duty cycle deviation are held as the period is varied. Width deviation commands are converted to duty cycle deviation values.

Minimum width and edge time restrictions apply. May cause a change in the selected edge times, duty cycle, or both.

**NOTE**

The **FUNction:PULSe:HOLD** command does not limit period settings. The pulse width or duty cycle may be adjusted if necessary to accommodate a new period setting.

[SOURce[1|2]:]FUNction:PULSe:PERiod <seconds>|MINimum|MAXimum|DEFault  
 [SOURce[1|2]:]FUNction:PULSe:PERiod? [MINimum|MAXimum]

Sets the period for pulse waveforms. This command is paired with the **FREQuency** command; the one executed last overrides the other, as frequency and period specify the same parameter.

Parameter	Typical Return
From reciprocal of instrument's <b>maximum frequency</b> up to 1,000,000 s. Default 1 ms	+2.000000000000000E-07
Set the period to 500 ms: FUNC:PULS:PER .5 or FUNC:PULS:PER 500 ms	

**Remarks**

- The specified period must be greater than the sum of the pulse width and the edge time. The instrument will adjust edge time and pulse width as needed to accommodate the specified period. From the remote interface, a "Settings conflict" error will also be generated. The edge time is minimized first, and then the width (or duty cycle) is adjusted as shown below.

$$\text{Period} \geq [\text{Pulse Width} + ((\text{Lead Edge Time} + \text{Trail Edge Time}) * 0.625)]$$

- This command affects the period (and frequency) for all waveform functions (not just pulse). For example, if you select a period using FUNCtion:PULSe:PERiod and then change the output function to sine wave, the specified period will be used for the new function.
- Function Limitations: If you change to a function whose minimum period exceeds the value set by this command, the period is adjusted to the new function's minimum pulse. For example, if you set a period of 2 μs and then change to the ramp function, the instrument adjusts the period to 5 μs (the minimum for ramps). From the remote interface, a "Settings conflict" error will also be generated.

[SOURce[1|2]:]FUNction:PULSe:TRANsition[:BOTH] <seconds>|MINimum|MAXimum|DEFault  
[SOURce[1|2]:]FUNction:PULSe:TRANsition:LEADing <seconds>|MINimum|MAXimum|DEFault  
[SOURce[1|2]:]FUNction:PULSe:TRANsition:LEADing? [MINimum|MAXimum]  
[SOURce[1|2]:]FUNction:PULSe:TRANsition:TRAIing <seconds>|MINimum|MAXimum|DEFault  
[SOURce[1|2]:]FUNction:PULSe:TRANsition:TRAIing? [MINimum|MAXimum]

Sets the pulse edge time on the leading, trailing, or both edges of a pulse.

Parameter	Typical Return
8.4 ns to 1 $\mu$ sec Default 10 ns, limited as described below	+1.0000000000000000E-08
Set leading edge time to 10 ns (two methods):	
FUNC:PULS:TRAN:LEADing 10 ns	
FUNC:PULS:TRAN:LEADing .000000010	

**Remarks**

- The leading edge time applies to rising edge, and represents the time from the 10% threshold to the 90% threshold of the edge; the trailing edge represents the time from the 90% threshold to the 10% threshold.
- The specified edge time must fit within the specified pulse width and period. The instrument will limit the edge time to accommodate the specified pulse width or duty cycle. From the remote interface, a "Settings conflict" error will also be generated.

[SOURce[1|2]:]FUNCTION:PULSE:WIDTH <seconds>|MINimum|MAXimum|DEFAULT  
 [SOURce[1|2]:]FUNCTION:PULSE:WIDTH? [MINimum|MAXimum]

Sets pulse width.

Parameter	Typical Return
16 ns up to approximately 1,000,000 s, limited as described below Default 100 $\mu$ s	+5.000000000000000E-03
Set pulse width to 5 ms (two methods):	
FUNC:PULS:WIDT 5 ms	
FUNC:PULS:WIDT .005	

#### Remarks

- The **FUNCTION:PULSE:DCYCLE** and **FUNCTION:PULSE:WIDTH** commands affect the same parameter. In some applications, it is natural to adjust pulse width directly (in seconds); in others, adjusting duty cycle seems more natural. When frequency is adjusted, if pulse width was most recently adjusted as duty cycle on the front panel, then duty cycle will be kept constant as frequency or period changes. However, if pulse width was the last setting, then pulse width will be kept constant as frequency or period changes. See **FUNCTION:PULSE:HOLD**.
- Pulse width is the time from the 50% threshold of a pulse's rising edge to the 50% threshold of the next falling edge.
- The specified pulse width must be less than the difference between the *period* and the *minimum pulse width* as shown below. The instrument will adjust pulse edge time first and then limit pulse width as needed to accommodate the period. From the remote interface, a "Settings conflict" error will also be generated.

$$\text{Pulse Width} \leq \text{Period} - W_{\text{min}}$$

- The specified pulse width must also be less than the difference between the *period* and the *edge time* as shown below. The instrument will adjust pulse edge time first and then limit pulse width as needed to accommodate the period. From the remote interface, a "Settings conflict" error will also be generated.

$$\text{Pulse Width} \leq [\text{Period} - ((\text{Leading Edge Time} + \text{Trailing Edge Time}) * 0.625)]$$

- The pulse width must also be greater than the total time of one edge as shown below.

$$\text{Pulse Width} \geq [(\text{Leading Edge Time} + \text{Trailing Edge Time}) * 0.625]$$



[SOURce[1|2]:]FUNCtion:RAMP:SYMMetry <percent>|MINimum|MAXimum|DEFault  
 [SOURce[1|2]:]FUNCtion:RAMP:SYMMetry? [MINimum|MAXimum]

Sets the symmetry percentage for ramp waves.

Parameter	Typical Return
0 to 100 Default 100	+5.000000000000000E+01
Set symmetry to 50%: FUNC:RAMP:SYMM 50	

- Symmetry represents the amount of time per cycle that the ramp wave is rising (assuming that the waveform polarity is not inverted).

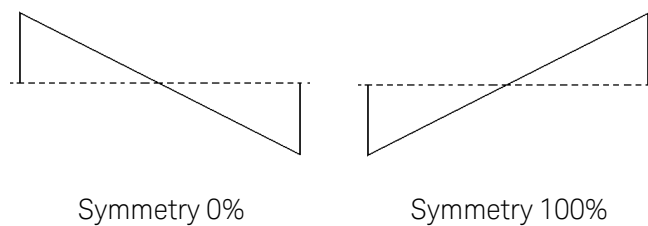

- For ramp waveforms, the **APPLY:RAMP** command overrides the current symmetry setting and selects 100%. To set a symmetry other than 100%, select the ramp waveform output with the **FUNCTION RAMP** command, then use **FUNCtion:RAMP:SYMMetry** to set the symmetry.
- The symmetry setting is remembered when you change from ramp wave to another function. When you return to the ramp wave function, the previous symmetry is used.
- When ramp is the modulating waveform for AM, FM, PM, or PWM, the symmetry setting does not apply. The instrument always uses a ramp waveform with 100% symmetry.

[SOURce[1|2]:]FUNction:SQUare:DCYClE <percent>|MINimum|MAXimum|DEFault  
[SOURce[1|2]:]FUNction:SQUare:DCYClE? [MINimum|MAXimum]

Sets duty cycle percentage for square wave.

Parameter	Typical Return
0.01 to 99.99, subject to limitation of 16 ns minimum pulse width Default 50	+5.000000000000000E+01
Set duty cycle to 30%: FUNC:SQU:DCYC 30	
Sets the duty cycle to its minimum value: FUNC:SQU:DCYC MIN	

#### Remarks

- Duty cycle represents the amount of time per cycle that the square wave is at a high level (assuming normal polarity).
- For square waveforms, **APPLY:SQUare** replaces the current duty cycle setting with 50%. To set a duty cycle other than 50%, select the square wave with **FUNCTion SQUare**, then use **FUNCTion:SQUare:DCYClE**.
- The duty cycle setting is remembered when you change from square wave to another function. When you return to square wave, the previous duty cycle is used.
- Limits Due to Frequency: As frequency is increased, minimum and maximum duty cycle limits are adjusted to maintain a minimum pulse width of 16 ns. For example, at 1 MHz the minimum duty cycle is 1.60% and maximum duty cycle is 98.40%. At 10 MHz, the minimum duty cycle is 16.00% and the maximum duty cycle is 84.00%.
- If you select a square waveform as the modulating waveform for AM, FM, PM, or PWM, the instrument always uses a square wave with 50% duty cycle.

[SOURce[1|2]:]FUNCtion:SQUare:PERiod <seconds>|MINimum|MAXimum|DEFault  
[SOURce[1|2]:]FUNCtion:SQUare:PERiod? [MINimum|MAXimum]

Sets period for square wave.

Parameter	Typical Return
From reciprocal of <b>maximum square wave frequency</b> to 1,000,000 s Default 1 ms	+5.000000000000000E-01
Set period to 500 ms (two methods):	
FUNC:SQUare:PER .5	
FUNC:SQUare:PER 500 ms	

#### Remarks

- Function Limitations: If you change to a function whose minimum period exceeds the value set by this command, the period is adjusted to the new function's minimum pulse. For example, if you set a period of 2  $\mu$ s and then change to the ramp function, the instrument adjusts the period to 5  $\mu$ s (the minimum for ramps). From the remote interface, a "Settings conflict" error will also be generated. From the remote interface, a "Settings conflict" error will also be generated.

## LIST Subsystem

Configures list of frequencies to be output by instrument. This permits faster frequency change to a predetermined list of frequencies. You may advance frequencies by either an external trigger, an internal trigger, or a BUS trigger. List is initiated by FREQuency:MODE LIST.

**LIST\_DWELL** - sets amount of time each frequency in list is generated.

**LIST\_FREQuency** - Specify up to 128 frequencies as a list (frequencies may also be read from or saved to a file using MMEMory:LOAD:LIST[1|2] and MMEMory:STORe:LIST).

**LIST\_FREQuency\_POINts** - Returns number of points in a frequency list.

For LIST programming example, see [Create a List of Frequencies](#).

[SOURce[1|2]:]LIST:DWELL <seconds>|MINimum|MAXimum  
 [SOURce[1|2]:]LIST:DWELL? [MINimum|MAXimum]

Sets dwell time, the amount of time each frequency in a frequency list is generated.

Parameter	Typical Return
1 $\mu$ s to 8000 s Default 1 s	+1.200000000000000E+01
Set dwell time for channel 1 to 12 s: LIST:DWEL 12	

**Remark**

- The instrument generates each frequency in a frequency list for the specified dwell time, when TRIGger [1|2]:SOURce is IMMEDIATE.

[SOURce[1|2]:]LIST:FREQUENCY <freq1>[{, <freq2>}]  
 [SOURce[1|2]:]LIST:FREQUENCY?

Specifies frequency values in a frequency list.

Parameter	Typical Return
List of 1 to 128 frequencies, each 1 $\mu$ Hz to maximum instrument frequency (up to 200 kHz for triangle and ramp). Default list: 100 Hz, 1000 Hz, and 550 Hz.	2.17800000E+006,3.14000000E+003, 6.28318000E+006
Set channel 1 frequency list to three frequency values: LIST:FREQ 2.718E6, 3.14E3, 6.28318E6	

**Remarks**

- This command overwrites the previous list with the new list.

[SOURce[1|2]:]LIST:FREQUENCY:POINTS? [MINimum|MAXimum]

Returns number of frequencies in current frequency list.

Parameter	Typical Return
MINimum MAXimum	+17
Return number of entries in the channel 1 frequency list: LIST:FREQ:POIN?	

**Remarks**

- The default list has three frequencies: 100 Hz, 1000 Hz, and 550 Hz.
- MINimum is 1, MAXimum is 128.

## MARKer Subsystem

The MARKer subsystem configures the point within an arbitrary waveform, sweep, or burst at which the front panel **Sync** signal goes low.

### Commands and Queries

- **[SOURCE[1|2]:]MARKer:CYCLE <cycle\_num>|MINimum|MAXimum|DEFault** - cycle of a burst at which **Sync** signal goes low
- **[SOURCE[1|2]:]MARKer:FREQUENCY <frequency>|MINimum|MAXimum|DEFault** - frequency at which **Sync** signal goes low
- **[SOURCE[1|2]:]MARKer:POINT <sample\_number>|MINimum|MAXimum** - point in an arbitrary waveform at which **Sync** signal goes low

If and only if the SYNC:MODE is set to MARKer, each of these commands causes sync/marker to transition to high at start of burst, sweep, or arbitrary waveform. **OUTPUT:SYNC:POLarity** may reverse this.

[SOURce[1|2]:]MARKer:CYCLe <cycle\_num>|MINimum|MAXimum|DEFault  
[SOURce[1|2]:]MARKer:CYCLe? [MINimum|MAXimum]

Sets the marker cycle number at which the front panel **Sync** signal goes low in a burst mode operation. **OUTPut:SYNC:POLarity** may reverse this.

Parameter	Typical Return
Whole number from 2 to number of cycles in the burst plus one (NCYCles+1). Default 2	+2.000000000000000E+03
Set the marker cycle to 2000: MARK:CYCL 2000	

#### Remarks

- This is valid only if burst is enabled and **OUTP:SYNC:MODE** is MARKer.
- With burst enabled, the marker cycle must be less than or equal to the number of cycles in the burst plus one. Attempting to set the marker cycle outside this range will set marker cycle equal to middle of burst. From the remote interface, a "Settings conflict" error will also be generated.

[SOURce[1|2]:]MARKer:FREQuency <frequency>|MINimum|MAXimum|DEFault  
[SOURce[1|2]:]MARKer:FREQuency? [MINimum|MAXimum]

Sets the marker frequency at which the front panel **Sync** signal goes low during a sweep. **OUTPut:SYNC:POLarity** may reverse this.

Parameter	Typical Return
Any frequency between start and stop frequency. Default 500 Hz	+2.000000000000000E+03
Set marker frequency to 2 kHz: MARK:FREQ 2000	

#### Remarks

- This is valid only if sweep is enabled and **OUTP:SYNC:MODE** is MARKer.
- When sweep is enabled, marker frequency must be between start frequency and stop frequency. Attempting to set the marker cycle outside this range will set marker frequency to start frequency or frequency (whichever is closer). From the remote interface, a "Settings conflict" error will also be generated.

[SOURce[1|2]:]MARKer:POINT <sample\_number>|MINimum|MAXimum  
 [SOURce[1|2]:]MARKer:POINT? [MINimum|MAXimum]

Sets the sample number at which the front panel **Sync** signal goes low within the active arbitrary waveform. **OUTPut:SYNC:POLarity** may reverse this.

Parameter	Typical Return
Whole number from 4 to number of samples in waveform, minus 3. Default is midpoint of arbitrary waveform	+1.000000000000000E+01
Set marker point to 10th sample in waveform: MARK:POIN 10	

**Remarks**

- Command only sets marker point in currently active arbitrary waveform (**FUNCTION:ARbitrary**).
- Command is valid only under these conditions:
  - **OUTPut:SYNC:MODE** set to MARK, FUNC set to ARB, **FREQuency:MODE** set to CW
  - **OUTPut:SYNC:MODE** set to CARR, FUNC set to ARB, **BURSt** ON.
  - **OUTPut:SYNC:MODE** set to CARR, FUNC set to ARB, **FREQuency:MODE** set to SWEEP.
  - **OUTPut:SYNC:MODE** set to MARK, internal modulation active, and either **FUNCTION** set to ARB or a modulating waveform's internal function is set to ARB.



## PHASe Subsystem

The PHASe subsystem allows you to adjust the waveform phase; this is useful in channel-to-channel and channel-to-Sync applications.

- **[SOURce[1|2]:]PHASe <angle>|MINimum|MAXimum|DEFault** - sets phase offset of output waveform (not available for arbitrary waveforms or noise)
- **[SOURce[1|2]:]PHASe:REFerence** - sets new zero-phase reference point without changing instrument output
- **[SOURce[1|2]:]PHASe:SYNChronize** - synchronizes phase of both internal channels on a two-channel instrument.
- **[SOURce[1]:]PHASe:UNLock:ERRor:STATe ON|1|OFF|0** - specifies whether instrument generates an error upon losing phase-lock

[SOURce[1|2]:]PHASe <angle>|MINimum|MAXimum|DEFault  
[SOURce[1|2]:]PHASe? [MINimum|MAXimum]

Sets waveform's phase offset angle.

Parameter	Typical Return
-360 to +360 degrees, $-2\pi$ to $+2\pi$ radians, or -(period) to +(period), as specified by <b>UNIT:ANGLE</b> . Default 0.	+1.5000000000000E+01
Set channel 1 phase offset to 15 degrees: UNIT:ANGL DEG PHAS 15	

#### Remarks

- Phase offset is independent of burst phase (**BURSt:PHASe**).
- This command does not modify channel's primary phase generator; it simply adds phase offset.
- This command also useful for modifying phase relationship between channels in a two-channel instrument and between the channel and its sync signal.
- In a two-channel instrument, use **PHASe:SYNChronize** to synchronize the phases of the two internal channels. Each channel will retain its current phase offset, but the two channels will have a common reference point so the channel-to-channel phase difference will be known.

[SOURce[1|2]:]PHASe:REFerence

Simultaneously removes the offset set by **PHASe** and adjusts the primary phase generator by an amount equivalent to the PHASe setting. This retains the phase relationship set with another instrument while realigning the sync signal with the output.

Parameter	Typical Return
(none)	(none)
Reset the zero-phase reference point for channel 1: PHAS:REF	

#### Remarks

- The primary purpose of this command is to establish a zero-point between two connected instruments. For channel-to-channel operation on a two-channel instrument, use **PHASe:SYNChronize**.
- Setting a new zero-phase reference point means that the value subsequently returned by a **PHASe?** query command is reset to "0", but the output waveform itself does not change.

## [SOURce[1|2]:]PHASe:SYNChronize

Simultaneously resets all phase generators in the instrument, including the modulation phase generators, to establish a common, internal phase zero reference point. This command does not affect **PHASe** setting of either channel; it simply establishes phase difference between channels as the sum of **SOUR1:PHAS** and **SOUR2:PHAS** instead of an arbitrary amount.

Parameter	Typical Return
(none)	(none)
Reset all phase generators: PHAS:SYNC	

### Remarks

- SOURce1 and SOURce2 mean nothing for this command.
- This command breaks the phase relation with another instrument, because it resets the phase generators.
- In single channel instruments, this synchronizes the main channel with the internal modulation generator.
- You can synchronize the phase between the primary signal and the **SUM** signal by sending **[SOURce [1|2]:]PHASe:SYNChronize** after setting the functions for the primary signal and the **SUM** signal. Otherwise, the phase between the two signals is arbitrary.

## [SOURce[1]:]PHASe:UNLock:ERRor:STATe ON|1|OFF|0 [SOURce[1]:]PHASe:UNLock:ERRor:STATe?

Enables or disables the generation of an error if the phase-lock is ever lost by the instrument timebase. The instrument uses one timebase for both channels.

Parameter	Typical Return
ON 1 OFF 0 Default OFF	0 (OFF) or 1 (ON)
Enable the generation of phase-lock errors: PHASe:UNLock:ERRor:STATe ON	

### Remarks

- Only SOURce1 accepted. SOURce2 will return -113,"Undefined header"
- If the phase-lock is lost and the error is enabled, a "Reference phase-locked loop is unlocked" error is generated.
- Volatile setting, lost on power cycle.

## PM Subsystem

The PM subsystem allows you to phase modulate a waveform.

This summarizes the steps required to generate a phase modulated waveform.

1. **Configure carrier waveform:** Use **FUNCTION**, **FREQUENCY**, **VOLTage**, and **VOLTage:OFFSet** to specify the carrier waveform's function, frequency, amplitude, and offset.
2. **Select modulation source (internal, CH1 or CH2):** **PM:SOURce**.
3. **Set modulating waveform:** **PM:INTernal:FUNCTION**
4. **Set modulating frequency:** **PM:INTernal:FREQUENCY**
5. **Set phase deviation:** **PM:DEVIation**
6. **Enable PM:** **PM:STATe:ON**

The following code produces the oscilloscope image shown below.

```
FUNCTION SQU
FREQUENCY +1.0E+04
VOLTage +1.0
VOLTage:OFFset 0.0
PM:SOURce INT
PM:DEVIation +90
PM:INTernal:FREQUENCY +2500
PM:INTernal:FUNCTION RAMP
PM:STATe 1
OUTPut1 1
```

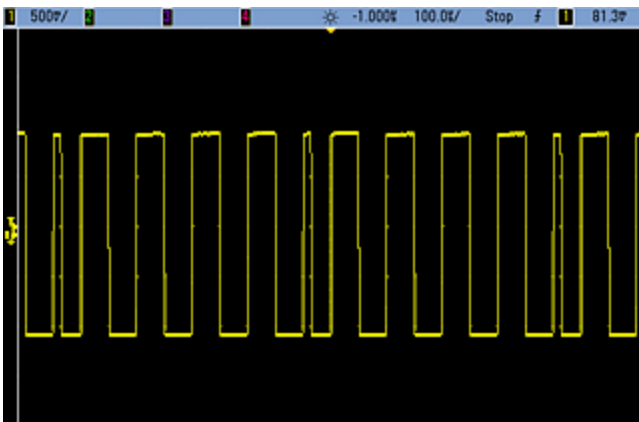

[SOURce[1|2]:]PM:DEVIation <deviation in degrees>|MINimum|MAXimum|DEFault  
[SOURce[1|2]:]PM:DEVIation? [MINimum|MAXimum]

Sets the phase deviation in degrees. This value represents the peak variation in phase of the modulated waveform from the carrier waveform.

Parameter	Typical Return
0 to 360 Default 180	+9.000000000000000E+01
Set phase deviation to ± 90 degrees PM:DEV 90	

[SOURce[1|2]:]PM:INTernal:FREQuency <frequency>|MINimum|MAXimum|DEFault  
[SOURce[1|2]:]PM:INTernal:FREQuency? [MINimum|MAXimum]

Sets the frequency of the modulating waveform. The waveform chosen as the modulating source will operate at that frequency, within the frequency limits of that waveform.

Parameter	Typical Return
1 µHz to the maximum allowed for the internal function. Default 10 Hz	+1.000000000000000E-06
Set modulating frequency to 10 kHz: PM:INT:FREQ 10000	
Set modulating frequency to 1 µHz: PM:INT:FREQ MIN	

#### Remarks

- When you select an arbitrary waveform as the modulating source, the frequency changes to the frequency of the arbitrary waveform, which is based on the sample rate and the number of points in the arbitrary waveform.
- When using an arbitrary waveform for the modulating source, changing this parameter also changes the cached metadata representing the arbitrary waveform's sample rate. You can also change the modulating frequency of an arbitrary waveform with **FUNCTION:ARbitrary:FREQuency**, **FUNCTION:ARbitrary:PERiod**, and **FUNCTION:ARbitrary:SRATe**. These commands and the modulation frequency command are directly coupled in order to keep the arbitrary waveform behaving exactly as it was last played. If you later turn modulation off and select that same arbitrary waveform as the current function, its sample rate (and corresponding frequency based upon the number of points) will be the same as it was when played as the modulation source.
- If the internal function is TRIngle, UpRamp, or DnRamp, the maximum frequency is limited to 200 kHz on the EDU33210 Series. If the internal function is PRBS, the frequency refers to bit rate and is limited as **shown here**.
- This command should be used only with the internal modulation source (**PM:SOURce INTernal**).

[SOURce[1|2]:]PM:INTernal:FUNCTion <function>  
[SOURce[1|2]:]PM:INTernal:FUNCTion?

Selects shape of modulating waveform.

Parameter	Typical Return
SINusoid SQUare RAMP NRAMp TRIangle NOISe PRBS ARB Default SINusoid	SIN, SQU, RAMP, NRAM, TRI, NOIS, PRBS, or ARB
<a href="#">View internal function waveforms.</a>	
Select a sine wave as the modulating waveform: PM:INT:FUNC SIN	

**Remarks**

- This command should be used only with the internal modulation source (**PM:SOURce INTernal**).
- You can use noise as the modulating waveform, but you cannot use noise, pulse, or DC as the carrier.

[SOURce[1|2]:]PM:SOURce INTernal|CH1|CH2  
[SOURce[1|2]:]PM:SOURce?

Selects the source of the modulating signal.

Parameter	Typical Return
INTernal CH1 CH2 Default INTernal	INT, CH1, or CH2
Select internal modulation source: PM:SOUR INT	

**Remarks**

- A channel may not be its own modulation source.

[SOURce[1|2]:]PM:STATe ON|1|OFF|0  
[SOURce[1|2]:]PM:STATe?

Enables or disables modulation.

Parameter	Typical Return
ON 1 OFF 0 Default OFF	0 (OFF) or 1 (ON)
Enable PM: AM:STAT ON	

#### Remarks

- To avoid multiple waveform changes, enable modulation after configuring the other modulation parameters.
- Only one modulation mode may be enabled at a time.
- The instrument will not enable modulation with sweep or burst enabled. When you enable modulation, the sweep or burst mode is turned off.

#### See Also

- [AM Subsystem](#)
- [BPSK Subsystem](#)
- [FM Subsystem](#)
- [FSKey Subsystem](#)
- [PWM Subsystem](#)

## PWM Subsystem

The PWM subsystem allows you to perform pulse width modulation (PWM) on a pulse waveform.

### Example

This summarizes the steps required to generate a PWM waveform.

1. **Configure a pulse carrier waveform:** Use **FUNCTION**, **FREQUENCY**, **VOLTage**, and **VOLTage:OFFSet** to specify the carrier waveform's function, frequency, amplitude, and offset.
2. **Select modulation source (internal, CH1, or CH2):** **PWM:SOURce**.
3. **Select modulating waveform:** **PWM:INTernal:FUNCTION**
4. **Set modulating frequency:** **PWM:INTernal:FREQUENCY**
5. **Set pulse width or duty cycle deviation:** **PWM:DEVIation** or **PWM:DEVIation:DCYCLE**
6. **Enable PWM:** **PWM:STATe:ON**

The following code produces the oscilloscope image shown below.

```
FUNCTION PULS
FREQUENCY +5000.0
VOLTage +1.0
VOLTage:OFFS +0.0
PWM:DEVIation +5.0E-05
PWM:DEVIation:DCYCLE +25.0
PWM:INTernal:FREQUENCY +1000.0
PWM:INTernal:FUNCTION RAMP
PWM:STATe 1
OUTPut1 1
```

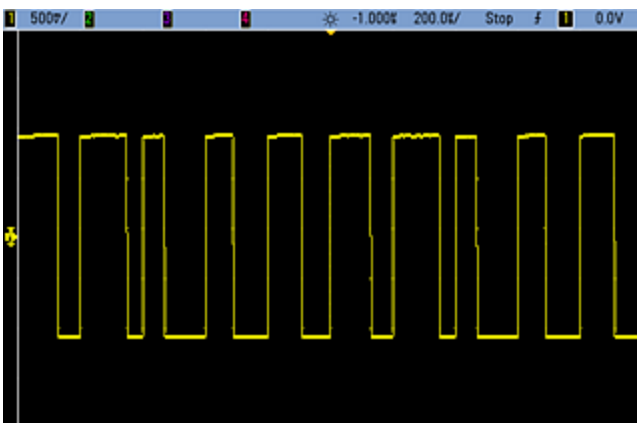



[SOURce[1|2]:]PWM:DEVIation <deviation>|MINimum|MAXimum|DEFault  
[SOURce[1|2]:]PWM:DEVIation? [MINimum|MAXimum]

Sets pulse width deviation; the  $\pm$  variation in width (in seconds) from the pulse width of the carrier pulse waveform.

Parameter	Typical Return
0 to 500,000 (seconds) Default 10 $\mu$ s	+1.000000000000000E+00
Set pulse width deviation to 1 s: PWM:DEV 1	
Set pulse width deviation to 0 s: PWM:DEV MIN	

#### Remarks

- The deviation is a  $\pm$  deviation, so if the pulse width is 10 ms and the deviation is 4 ms, the width can vary from 6 to 14 ms.
- The pulse width deviation cannot exceed the current pulse width, and is also limited by the minimum pulse width ( $W_{min}$ ):  
$$\text{Width Deviation} < \text{Pulse Width} - W_{min}$$
and  
$$\text{Width Deviation} < \text{Period} - \text{Pulse Width} - W_{min}$$
- The pulse width deviation is limited by the current edge time setting.  
$$\text{Width Deviation} < \text{Pulse Width} - (0.8 \times \text{Leading Edge Time}) - (0.8 \times \text{Trailing Edge Time})$$
and  
$$\text{Width Deviation} < \text{Period} - \text{Pulse Width} - (0.8 \times \text{Leading Edge Time}) - (0.8 \times \text{Trailing Edge Time})$$

[SOURce[1|2]:]PWM:DEVIation:DCYClE <deviation\_in\_pct>|MINimum|MAXimum|DEFault  
 [SOURce[1|2]:]PWM:DEVIation:DCYClE? [MINimum|MAXimum]

Sets duty cycle deviation in percent of period. This is the peak variation in duty cycle from the underlying pulse waveform. For example, if duty cycle is 10% and duty cycle deviation is 5%, the duty cycle of the modulated waveform will vary from 5% to 15%.

Parameter	Typical Return
Duty cycle in percent of period, from 0 to 50 Default 1	+5.0000000000000000E+00
Set pulse width deviation to 5%: PWM:DEV:DCYC 5	

**Remarks**

- Duty cycle deviation cannot exceed pulse duty cycle.
- Duty cycle deviation also limited by minimum pulse width (Wmin):
 
$$\text{Duty Cycle Deviation} < \text{Duty Cycle} - 100 \times W_{\text{min}} \div \text{Period}$$
 and
 
$$\text{Duty Cycle Deviation} < 100 - \text{Duty Cycle} - 100 \times W_{\text{min}} \div \text{Period}$$
 where  $W_{\text{min}} = 16 \text{ ns}$
- Duty cycle deviation limited by edge time.
 
$$\text{Duty Cycle Dev} < \text{Duty Cycle} - (80 \times \text{Leading Edge Time}) \div \text{Period} - (80 \times \text{Trailing Edge Time}) \div \text{Period}$$
 and
 
$$\text{Duty Cycle Dev} < 100 - \text{Duty Cycle} - (80 \times \text{Leading Edge Time}) \div \text{Period} - (80 \times \text{Trailing Edge Time}) \div \text{Period}$$

[SOURce[1|2]:]PWM:INTernal:FREQuency <frequency>|MINimum|MAXimum|DEFault  
[SOURce[1|2]:]PWM:INTernal:FREQuency? [MINimum|MAXimum]

Selects frequency at which output pulse width shifts through its pulse width deviation. The waveform used as the modulating source will operate at that frequency, within frequency limits of that waveform.

Parameter	Typical Return
1 μHz to the <b>maximum allowed for the internal function</b> . Default 10 Hz	+1.000000000000000E+02
Set internal PWM frequency to 100 Hz: PWM:INT:FREQ 100	

#### Remarks

- When you select an arbitrary waveform as the modulating source, the frequency changes to the frequency of the arbitrary waveform, which is based on the sample rate and the number of points in the arbitrary waveform.
- When using an arbitrary waveform for the modulating source, changing this parameter also changes the cached metadata representing the arbitrary waveform's sample rate. You can also change the modulating frequency of an arbitrary waveform with **FUNCTION:ARbitrary:FREQuency**, **FUNCTION:ARbitrary:PERiod**, and **FUNCTION:ARbitrary:SRATe**. These commands and the modulation frequency command are directly coupled in order to keep the arbitrary waveform behaving exactly as it was last played. If you later turn modulation off and select that same arbitrary waveform as the current function, its sample rate (and corresponding frequency based upon the number of points) will be the same as it was when played as the modulation source.
- If the internal function is TRIngle, UpRamp, or DnRamp, the maximum frequency is limited to 200 kHz on the EDU33210 Series. If the internal function is PRBS, the frequency refers to bit rate and is limited as **shown here**.
- This command should be used only with the internal modulation source (**PWM:SOURce INTernal**).

[SOURce[1|2]:]PWM:INTernal:FUNction <function>  
[SOURce[1|2]:]PWM:INTernal:FUNction?

Selects shape of the internal modulating waveform.

Parameter	Typical Return
SINusoid SQUare RAMP NRAMp TRIngle NOISe PRBS ARB Default SINusoid	SIN, SQU, RAMP, NRAM, TRI, NOIS, PRBS, or ARB
<b>View internal function waveforms.</b>	
Select a sine wave as the modulating waveform shape: PWM:INT:FUNC SIN	

#### Remarks

- This command should be used only with the internal modulation source (**PWM:SOURce INTernal**).

[SOURce[1|2]:]PWM:SOURce INTernal|CH1|CH2  
[SOURce[1|2]:]PWM:SOURce?

Selects the source of the modulating signal.

Parameter	Typical Return
INTernal CH1 CH2 Default INTernal	INT, CH1, or CH2
Select internal modulation source: PWM:SOUR INT	

#### Remarks

- A channel may not be its own modulation source.

[SOURce[1|2]:]PWM:STATe ON|1|OFF|0  
[SOURce[1|2]:]PWM:STATe?

Enables or disables modulation.

Parameter	Typical Return
ON 1 OFF 0 Default OFF	0 (OFF) or 1 (ON)
Enable PWM : PWM:STAT ON	

#### Remarks

- To avoid multiple waveform changes, enable modulation after configuring the other modulation parameters.
- Only one modulation mode may be enabled at a time.
- The instrument will not enable modulation with sweep or burst enabled. When you enable modulation, the sweep or burst mode is turned off.
- PWM is allowed only when pulse is the selected function.

#### See Also

- [AM Subsystem](#)
- [BPSK Subsystem](#)
- [FM Subsystem](#)
- [FSKey Subsystem](#)
- [PM Subsystem](#)

## RATE Subsystem

The RATE subsystem allows you to couple the outputs' sample rates on a two-channel instrument by specifying the following items:

- [SOURce[1|2]:]RATE:COUPlE[:STATe] ON|1|OFF|0
- [SOURce[1|2]:]RATE:COUPlE:MODE OFFSet|RATIo
- [SOURce[1|2]:]RATE:COUPlE:OFFSet <sample\_rate>|MINimum|MAXimum|DEFault
- [SOURce[1|2]:]RATE:COUPlE:RATIo <ratio>|MINimum|MAXimum|DEFault

[SOURce[1|2]:]RATE:COUPlE[:STATe] ON|1|OFF|0  
[SOURce[1|2]:]RATE:COUPlE[:STATe]?

Enables or disables sample rate coupling between channels, or allows one-time copying of one channel's sample rate into the other channel.

Parameter	Typical Return
ON 1 OFF 0 Default OFF	0 (OFF) or 1 (ON)
Turn on sample rate coupled state: RATE:COUP ON	

#### Remarks

- The ON value starts sample rate coupling in the mode specified by **RATE:COUPlE:MODE**.
- If the current offset or ratio, combined with the current sample rate settings, would cause either sample rate to exceed instrument specifications, the instrument will generate an error and the exceeded sample rate will clip at its maximum or minimum value.
- If setting mode to **RATIO** and setting **RATIO** to 1.0 still exceeds the specifications of either channel, an error message will be generated and the **RATE:COUPlE[:STATe]** will not be turned ON.
- Both channels must be configured for **FUNCTION ARB** in order to enable sample rate coupling.

[SOURce[1|2]:]RATE:COUPlE:MODE OFFSet|RATio  
[SOURce[1|2]:]RATE:COUPlE:MODE?

Sets type of sample rate coupling to either a constant sample rate offset (**OFFSet**) or a constant ratio (**RATio**) between the channels' sample rates.

Parameter	Typical Return
OFFSet RATio Default RATio	OFFS or RAT
Set the sample rate coupling mode to OFFSet. RATE:COUP:MODE OFFSet	

#### Remarks

- The default **RATio** is 1.
- The default sample rate coupling is OFF.
- The **SOURce[1|2]** keyword is ignored; the setting applies to both channels.

[SOURce[1|2]:]RATE:COUPlE:OFFSet <sample\_rate>|MINimum|MAXimum|DEFAULT  
 [SOURce[1|2]:]RATE:COUPlE:OFFSet?

Sets sample rate offset when a two-channel instrument is in sample rate coupled mode OFFSet.

Parameter	Typical Return
Valid values depend on <b>FUNCTION:ARbitrary:FILTER</b> setting. For NORMAL and STEP, the range is between $\pm 250$ MSa/s. For OFF, the range is between $\pm 62.5$ MSa/s. In any case, default is 0.	+8.000000000000000E+02
Set sample rate offset of channel 2 to 10.3 kSa/s higher than sample rate of channel 1. RATE:COUPlE:OFFSet 10300	
Sets the sample rate offset of channel 1 to 45 kSa/s below the sample rate of channel 2. SOUR2:RATE:COUP:OFFS -45000	

**Remarks**

- When specifying OFFSet or RATio, the SOURce channel (SOURce1 or SOURce2) is used as the reference channel and the offset or ratio is applied to the other channel. For example, suppose **RATE:COUPlE[:STATe]** is ON and **RATE:COUPlE:MODE** is OFFSet. Furthermore, suppose channel 1 is operating at 2 kSa/s, and channel 2 is at 10 kSa/s. The command **SOUR1:RATE:COUP:OFFS 2.5** causes Channel 1 to remain at 2 Sa/s, and Channel 2 to be set to 4.5 Sa/s. As one channel's sample rate changes, the other channel's sample rate changes to maintain the specified coupling.
- If the sample rate coupling would cause either channel to exceed sample rate specifications for the present functions, the command will result in an error, and the sample rate will be set to its maximum or minimum limit for the channel.

[SOURce[1|2]:]RATE:COUPle:RATio <ratio>|MINimum|MAXimum|DEFault  
[SOURce[1|2]:]RATE:COUPle:RATio? [MINimum|MAXimum]

Sets offset ratio between channel sample rates when a two-channel instrument is in sample rate coupled mode RATio.

Parameter	Typical Return
0.001 to 1000 Default 1	+7.500000000000000E-1
Set channel 2's sample rate to twice that of channel 1. SOUR1:RATE:COUP:RATio 2	
Set channel 1's sample rate to 3.14 times that of channel 2. SOUR2:RATE:COUPle:RAT 3.14	

#### Remarks

- When specifying OFFSet or RATio, the SOURce channel (SOURce1 or SOURce2) is used as the reference channel and the offset or ratio is applied to the other channel. For example, suppose the instrument is coupled in RATio mode. Furthermore, suppose channel 1 is operating at 2 kSa/s, and channel 2 is at 10 kSa/s. The command **SOUR1:RATE:COUP:RAT 2.5** causes Channel 1 to remain at 2 kSa/s, and Channel 2 to be set to 5 kSa/s. As one channel's sample rate changes, the other channel's sample rate changes to maintain the specified coupling.
- If the sample rate coupling would cause either channel to exceed sample rate specifications for the present functions, the command will result in an error, and the sample rate will be set to its maximum or minimum limit for the channel.



## SUM Subsystem

The SUM subsystem adds a modulation source signal to a channel's primary signal. This allows you to generate a two-tone signal on one channel, or to add noise to a primary signal. The SUM function uses the **same secondary sources** as used by the modulation subsystems.

Only one modulation or SUM function may be active on a channel at a time, so you cannot add noise to an FM signal using only one channel. For this operation, use **COMBine:FEED**, which combines both channels of a two-channel instrument into one channel output connector.

When signals are SUMmed:

- Their peak amplitude may not exceed the instrument's output rating.
- No other internal modulation is possible on that channel.

You can synchronize the phase between the primary signal and the **SUM** signal by sending **[SOURce [1|2]:]PHASe:SYNChronize** after setting the functions for the primary signal and the **SUM** signal. Otherwise, the phase between the two signals is arbitrary.

### NOTE

When the source is the other channel, there is a noticeable delay (as much as 350 ns) relative to the carrier even after **PHAS:SYNC**. Use the **Combine** feature for the other channel whenever possible.

---

### Example

To create a SUM waveform:

1. **Configure carrier waveform:** Use **FUNCTION**, **FREQuency**, **VOLTage**, and **VOLTage:OFFSet** to specify the carrier waveform's function, frequency, amplitude, and offset.
2. **Select the summing source:** The instrument accepts an internal, Channel 1, or Channel 2 source. Select the modulation source with **SUM:SOURce**.
3. **Configure the summing waveform:** Use **FUNCTION**, **FREQuency**, **VOLTage**, and **VOLTage:OFFSet** commands to configure the summing waveform.
4. **Set the amplitude percentage to sum:** **SUM:AMPLitude**.
5. **Enable SUM Modulation:** **SUM:STATe:ON**.
6. If using the other channel of a two-channel instrument, synchronize the channels: **PHASe:SYNChronize**.

The following code produces the oscilloscope image shown below.

```
SOURce1:FUNction RAMP
SOURce1:FREQuency +2000.0
SOURce1:VOLTagE +1.0
SOURce1:VOLTagE:OFFS +0.0
SOURce1:FUNction:RAMP:SYMMetry +50.0
SOURce2:FUNction SQU
SOURce2:FREQuency +4000.0
SOURce2:VOLTagE +1.0
SOURce2:VOLTagE:OFFS +0.0
SOURce1:SUM:AMPLitude +50.0
SOURce1:SUM:SOURce CH2
SOURce1:SUM:STATe 1
SOURce1:PHASe:SYNC
OUTPut1 1
OUTPut2 1
```

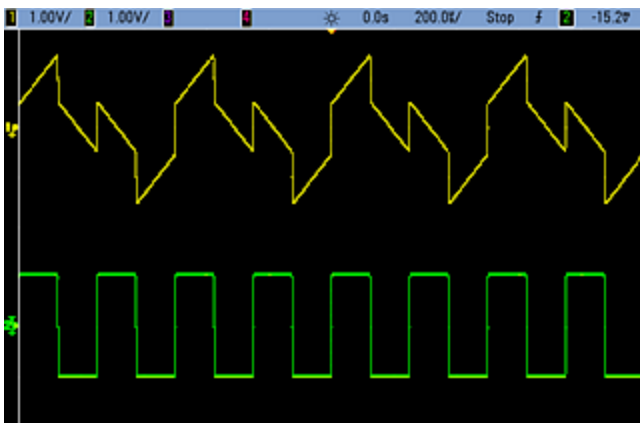

[SOURce[1|2]:]SUM:AMPLitude <amplitude>|MINimum|MAXimum|DEFault  
[SOURce[1|2]:]SUM:AMPLitude? [MINimum|MAXimum]

Sets internal modulation depth (or "percent modulation") in percent.

Parameter	Typical Return
Desired SUM signal amplitude in percent of carrier amplitude, from 0 to 100 Default 0.1	+3.2000000000000000E+00
Set the internal SUM signal amplitude to 1.0% of the signal amplitude: SUM:AMPL 1.0 PHAS:SYNC	
Set the internal sum signal amplitude on channel 2 to 0.15% of the signal amplitude: SOUR2:SUM:AMPL 0.15	

#### Remarks

- You can synchronize the phase between the primary signal and the **SUM** signal by sending **[SOURce [1|2]:]PHASe:SYNChronize** after setting the functions for the primary signal and the **SUM** signal. Otherwise, the phase between the two signals is arbitrary.
- Summed output cannot exceed  $\pm 5$  V peak output (into a 50  $\Omega$  load).

[SOURce[1|2]:]SUM:INTernal:FREQuency <frequency>|MINimum|MAXimum|DEFault  
[SOURce[1|2]:]SUM:INTernal:FREQuency? [MINimum|MAXimum]

Sets the frequency of the summing waveform when internal sum source is selected (**SUM:SOURce:INTernal**). The modulating source waveform operates at that frequency, within the frequency limits of that waveform.

Parameter	Typical Return
1 $\mu$ Hz to the <b>maximum allowed for the internal function</b> . Default 100 Hz	+1.000000000000000E-06
The following command sets the summing frequency to 10 kHz on Channel 2: <code>SOUR2:SUM:INT:FREQ 10000</code>	
SOUR2:PHAS:SYNC The following command sets the summing frequency to 1 $\mu$ Hz on Channel 1: <code>SUM:INT:FREQ MIN</code> <code>PHAS:SYNC</code>	

#### Remarks

- You can synchronize the phase between the primary signal and the **SUM** signal by sending **[SOURce [1|2]:]PHASe:SYNChronize** after setting the functions for the primary signal and the **SUM** signal. Otherwise, the phase between the two signals is arbitrary.
- When you select an arbitrary waveform as the modulating source, the frequency changes to the frequency of the arbitrary waveform, which is based on the sample rate and the number of points in the arbitrary waveform.
- When using an arbitrary waveform for the modulating source, changing this parameter also changes the cached metadata representing the arbitrary waveform's sample rate. You can also change the modulating frequency of an arbitrary waveform with **FUNCTION:ARbitrary:FREQuency**, **FUNCTION:ARbitrary:PERiod**, and **FUNCTION:ARbitrary:SRATe**. These commands and the modulation frequency command are directly coupled in order to keep the arbitrary waveform behaving exactly as it was last played. If you later turn modulation off and select that same arbitrary waveform as the current function, its sample rate (and corresponding frequency based upon the number of points) will be the same as it was when played as the modulation source.
- If the internal function is TRIngle, UpRamp, or DnRamp, the maximum frequency is limited to 200 kHz on the EDU33210 Series. If the internal function is PRBS, the frequency refers to bit rate and is limited as **shown here**.

[SOURce[1|2]:]SUM:INTernal:FUNcTion <function>  
[SOURce[1|2]:]SUM:INTernal:FUNcTion?

Selects the summing waveform (the waveform added to the primary waveform).

Parameter	Typical Return
SINusoid SQUare RAMP NRAMp TRIangle NOISe PRBS ARB Default SINusoid	SIN, SQU, RAMP, NRAM, TRI, NOIS, PRBS, or ARB
Select a sine wave as the summing waveform shape for channel 2: SOUR2:SUM:INT:FUNC SIN	

**Remarks**

- You can synchronize the phase between the primary signal and the **SUM** signal by sending [SOURce [1|2]:]PHASe:SYNChronize after setting the functions for the primary signal and the **SUM** signal. Otherwise, the phase between the two signals is arbitrary.
- This command is applicable only with internal sum source (SUM:SOURce INTernal).
- You cannot use SUM when DC is the carrier.
- An arbitrary waveform may not simultaneously be a carrier and a sum waveform.

The following table shows which carriers can be associated with which internal functions.

Modulating Signal						
Carrier	Sine	Square	Tri / Ramp	Noise	PRBS	Arb
Sine	.	.	.	.	.	.
Square/Pulse	.	.	.	.	.	.
Ramp/Triangle	.	.	.	.	.	.
Gaussian Noise	.	.	.	.	.	.
PRBS	.	.	.	.	.	.
Arbitrary	.	.	.	.	.	.

[SOURce[1|2]:]SUM:SOURce INTernal|CH1|CH2  
[SOURce[1|2]:]SUM:SOURce?

Selects source of summing signal.

Parameter	Typical Return
INTernal CH1 CH2 Default INTernal	INT, CH1, or CH2
Set the sum source to INTernal: SUM:SOUR INT	

#### Remarks

- You can synchronize the phase between the primary signal and the **SUM** signal by sending [SOURce [1|2]:]PHASe:SYNChronize after setting the functions for the primary signal and the **SUM** signal. Otherwise, the phase between the two signals is arbitrary.

[SOURce[1|2]:]SUM:STATe ON|1|OFF|0  
[SOURce[1|2]:]SUM:STATe?

Disables or enables SUM function.

Parameter	Typical Return
ON 1 OFF 0 Default OFF	0 (OFF) or 1 (ON)
Enable SUM SUM:STAT ON	

#### Remarks

- You can synchronize the phase between the primary signal and the **SUM** signal by sending [SOURce [1|2]:]PHASe:SYNChronize after setting the functions for the primary signal and the **SUM** signal. Otherwise, the phase between the two signals is arbitrary.
- To avoid multiple waveform changes, enable SUM after you have configured the other sum parameters.
- Only one modulation mode may be enabled at a time.
- The instrument will not allow SUM to be enabled when sweep or burst is enabled. When you enable SUM, the sweep or burst mode is turned off.
- With SUM:STATe ON, the sum amplitude plus the carrier amplitude may not exceed either the programmed limits or the instrument's output rating. If setting SUM:STATe ON would cause either the output rating or the limits to be exceeded, SUM:STATe will be set OFF and the instrument will report a settings conflict error.

## SWEEP Subsystem

To generate a frequency sweep:

1. **Select the waveform shape, amplitude and offset:** Use **APPLY** or the equivalent **FUNCTION**, **FREQUENCY**, **VOLTAGE**, and **VOLTAGE:OFFSET** commands to select the function, frequency, amplitude, and offset. You can select a sine, square, ramp, pulse, or arbitrary waveform (noise, PRBS, and DC are not allowed).
2. **Select sweep's frequency boundaries:** **FREQUENCY:START** and **FREQUENCY:STOP** , or **FREQUENCY:CENTER** and **FREQUENCY:SPAN**
3. **Select linear or logarithmic sweep mode:** **SWEep:SPACing**
4. **Set sweep time:** **SWEep:TIME**
5. **Set sweep hold and return times:** **SWEep:HTIME** and **SWEep:RTIME**
6. **Select sweep trigger source:** **TRIGger[1|2]:SOURCE**
7. **Set the marker frequency (optional):** **MARKer:FREQUENCY**
8. **Enable sweep:** **SWEep:STATE ON**

The following code produces the waveform shown below.

```
SOURce1:FUNCTION SINE
SOURce1:FREQuency +2.0E+03
SOURce1:FREQuency:START +2.0E+03
SOURce1:FREQuency:STOP +6.0E+03
SOURce1:VOLTage +1.0
SOURce1:VOLTage:OFFS +0.0
SOURce1:SWEep:TIME +5.0E-03
TRIGger1:SOURce IMM
SOURce1:FREQuency:MODE SWE
OUTPut1 1
```

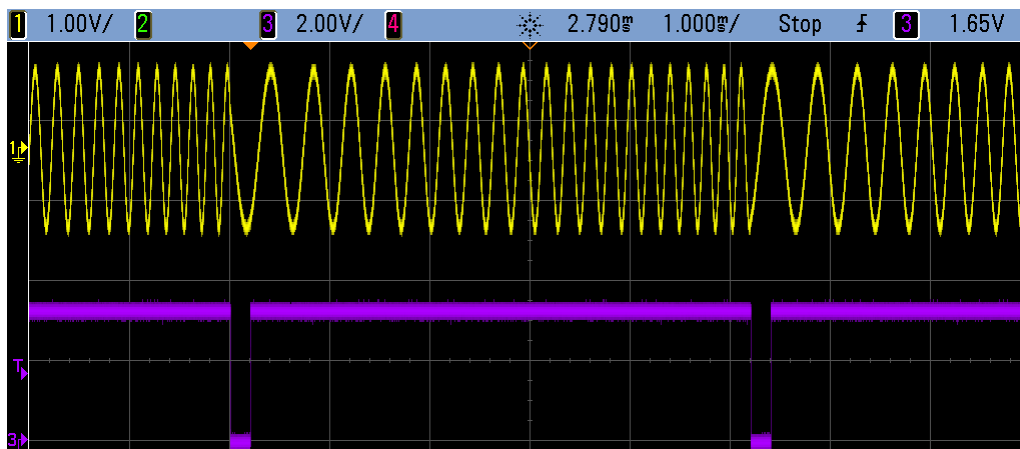

[SOURce[1|2]:]SWEep:HTIME <hold\_time>|MINimum|MAXimum|DEFault  
[SOURce[1|2]:]SWEep:HTIME? [MINimum|MAXimum]

Sets number of seconds the sweep holds (pauses) at the stop frequency before returning to the start frequency.

Parameter	Typical Return
0 to 3600 Default 0	+3.400000000000000E+00
Set sweep hold time to 3.4 seconds: SWE:HTIM 3.4	

[SOURce[1|2]:]SWEep:RTIME <return\_time>|MINimum|MAXimum|DEFault  
[SOURce[1|2]:]SWEep:RTIME? [MINimum|MAXimum]

Sets number of seconds the sweep takes to return from stop frequency to start frequency.

Parameter	Typical Return
0 to 3600 Default 0	+5.600000000000000E+00
Set sweep return time to 5.6 s: SWE:RTIM 5.6	

[SOURce[1|2]:]SWEep:SPACing LINear|LOGarithmic  
[SOURce[1|2]:]SWEep:SPACing?

Selects linear or logarithmic spacing for sweep.

Parameter	Typical Return
LINear LOGarithmic Default LIN	LIN or LOG
Set logarithmic sweep spacing: SWE:SPAC LIN	

#### Remarks

- **LINear**: output frequency varies linearly (from start frequency to stop frequency) during sweep.
- **LOGarithmic**: output frequency varies logarithmically (from start frequency to stop frequency) during sweep.



[SOURce[1|2]:]SWEep:STATe ON|1|OFF|0  
[SOURce[1|2]:]SWEep:STATe?

Enables or disables the sweep.

Parameter	Typical Return
ON 1 OFF 0 Default OFF	0 (OFF) or 1 (ON)
Enable sweep: SWE:STAT ON	

[SOURce[1|2]:]SWEep:TIME <seconds>|MINimum|MAXimum|DEFault  
[SOURce[1|2]:]SWEep:TIME? [MINimum|MAXimum]

Sets time (seconds) to sweep from start frequency to stop frequency.

Parameter	Typical Return
1 ms to 250,000 s for linear sweep, up to 500 s for logarithmic sweep Default 1 s	+2.500000000000000E+01
Set sweep time to 25 s: SWE:TIME 25	

#### Remarks

- The number of discrete frequency points in the sweep is calculated based on the sweep time.

[SOURce[1|2]:]TRACk ON|OFF|INVerted  
[SOURce[1|2]:]TRACk?

Causes channels 1 and 2 of a two-channel instrument to output the same signal, or an inverted polarity signal.

Parameter	Typical Return
ON OFF INVerted	ON, OFF, or INV
Set channel 2 to output a signal identical to that of channel 1: TRACk ON	

#### Remarks

- Causes all settings of the named channel to be copied to the other channel with exceptions noted below. This does include frequency list settings and any arbitrary waveforms loaded in memory.
- With the INVerted option, the tracking channel's amplitude will be inverted, forming a signal similar to a differential output between Channel 1 and Channel 2. DC Offset is not inverted.
- When TRACk is ON, voltage limits on both channels apply. If voltage limits on either channel would prevent the other channel's setup from being applied, the instrument will generate a settings conflict error and channel tracking will remain OFF.
- When TRACk is ON, changes to either channel are reflected in both channels. When TRACk is changed from ON or INV to OFF, the channels will remain in their present setup (frequency, amplitude, and so on), but you may now change one channel without affecting the other channel.
- Voltage limits may be adjusted in tracking mode, but cannot be set in violation of the current signal.
- Turning tracking ON sets **COMBine:FEED** to NONE, turns off **FREQuency:COUPle**, **VOLTage:COUPle**, and **RATE:COUPle**.
- TRACk is not allowed if the internal modulation source for the channel being tracked is the other channel.
- The **OUTPut:SYNC:SOURce** is set to the channel being tracked.

## VOLTage Subsystem

The VOLTage subsystem sets parameters related to output voltage.

### Example

The following is a typical procedure using the VOLTage subsystem.

1. Select the waveform shape, amplitude and offset: Use **APPLY** or the equivalent **FUNCTION**, **FREQUENCY**, **VOLTage**, and **VOLTage:OFFSet** commands to select the function, frequency, amplitude, and offset.
2. Set units for output amplitude:**VOLTage:UNIT**
3. Set output amplitude:**VOLTage**
4. Set DC offset voltage:**VOLTage:OFFSet**
5. Set high and low voltage level:**VOLTage:HIGH** and **VOLTage:LOW**
6. Select output voltage limits to protect device under test (DUT):**VOLTage:LIMit:HIGH**, **VOLTage:LIMit:LOW**, and **VOLTage:LIMit:STATe**
7. Select status of auto-ranging for all output functions:**VOLTage:RANGe:AUTO**
8. Set voltage coupling to lock amplitude and offset of the channels together (2-channel instruments only):**VOLTageLCOUPlE[:STATe]**

This example demonstrates the procedure outlined above:

```
SOURce1:FUNction SQU
SOURce1:FREQuency +1.0E+06
SOURce1:VOLTage +0.5
SOURce1:VOLTage:OFFSet +0.5
SOURce1:FUNction:SQUare:PERiod +1.0E-06
SOURce1:FUNction:PULSe:PERiod +1.0E-06
SOURce1:VOLTage:LIMit:LOW +0.0
SOURce1:VOLTage:LIMit:HIGH +1.0
SOURce1:VOLTage:LIMit:STATe 1
OUTP1 ON
SOURce2:FUNction SIN
SOURce2:FREQuency +1.0E+06
SOURce2:VOLTage +2.0
SOURce2:VOLTage:OFFSet +0.0
SOURce2:VOLTage:LIMit:LOW -1.0
SOURce2:VOLTage:LIMit:HIGH +1.0
SOURce2:VOLTage:LIMit:STATe 1
OUTP2 ON
```

[SOURce[1|2]:]VOLTage <amplitude>|MINimum|MAXimum|DEFAULT  
 [SOURce[1|2]:]VOLTage? [MINimum|MAXimum]

Sets output amplitude.

Parameter	Typical Return
1 mVpp to <b>maximum allowed for waveform and model</b> Default 100 mVpp	+5.0000000000000E+00
Set output amplitude to 5 Vpp: VOLT 5 Vpp	

#### Remarks

- The relationship between offset voltage and output amplitude is shown below.  $V_{max}$  is the maximum peak voltage for the selected output termination (5 V for a 50  $\Omega$  load or 10 V for a high-impedance load).

$$|V_{offset}| < V_{max} - V_{pp}/2$$

If the specified offset voltage is not valid, the instrument will adjust it to the maximum DC voltage allowed with the specified amplitude. From the remote interface, a "Data out of range" error will also be generated.

- *Differences between remote and front panel operation:*
  - *Remote Interface:* Setting amplitude from the remote interface can change the offset in order to achieve the desired amplitude. The instrument will generate either a "Data out of range" or "Settings conflict" error. If the specified offset voltage is not valid, the instrument adjusts it to the maximum allowed with the specified amplitude.
  - *Front Panel:* Setting amplitude from the front panel will not change the offset setting. If the specified amplitude is not valid, the instrument clips it to the maximum amplitude allowed with the current offset and generates a "Data out of range" error.
- *Limits Due to Output Termination:* If the amplitude is 10 Vpp and you change the output termination setting from 50  $\Omega$  to "high impedance" (**OUTPUT[1|2]:LOAD INF**), the displayed amplitude doubles to 20 Vpp. Changing from "high impedance" to 50  $\Omega$  halves the displayed amplitude. The output termination setting does not affect the actual output voltage; it only changes the values displayed and queried from the remote interface. Actual output voltage depends on the connected load.
- *Limits due to Output Coupling:*
  - *Differences between remote and front panel operation:* If two channels are coupled, both channels' amplitude limitations will be checked before a change in amplitude is executed. If a change in output amplitude would exceed a LIMIT for either channel, or exceed the instrument's output specifications for either channel:
    - **Remote interface:** The instrument will first adjust the offset, then if necessary, the amplitude of that channel to comply with the voltage limits or specification. The instrument will generate either a "Data out of range" or "Settings conflict" error.

- **Front panel:** The instrument will clip the amplitude value to the maximum value with the current offset setting. A "Data out of range" error will be generated.
- *Specifying Voltage Units:* You can set the output amplitude in Vpp, Vrms, or dBm by specifying the units as part of the VOLTage command VOLT 3.0 VRMS.

Use **VOLTage:UNIT** to specify output units for all subsequent commands.

You cannot specify output amplitude in dBm if output termination is set to high impedance. The units are automatically converted to Vpp.

- **Limits Due to Units Selection:** Amplitude limits are sometimes determined by the output units selected. This may occur when the units are Vrms or dBm due to the differences in various functions' crest factors. For example, if you change a 5 Vrms square wave (into 50  $\Omega$ ) to a sine wave, the instrument will adjust the amplitude to 3.536 Vrms (the upper limit for sine in Vrms). The remote interface will also generate a "Settings conflict" error.
- **Arbitrary Waveform Limitations:** For arbitrary waveforms, amplitude is limited if the waveform data points do not span the full range of the output DAC (Digital-to-Analog Converter). For example, the built-in "Sinc" waveform does not use the full range of values, so its maximum amplitude is limited to 6.087 Vpp (into 50  $\Omega$ ).
- **Changing amplitude may briefly disrupt output at certain voltages due to output attenuator switching.** The amplitude is controlled, however, so the output voltage will never exceed the current setting while switching ranges. To prevent this disruption, disable voltage autoranging using **VOLTage:RANGe:AUTO OFF**. The **APPLY** command automatically enables autoranging.
- You can also set the amplitude (with an associated offset voltage) by specifying a high level (**VOLTage:HIGH**) and low level (**VOLTage:LOW**). For example, if you set the high level to +2 V and the low level to -3 V, the resulting amplitude is 5 Vpp, with a -500 mV offset.
- To output a DC voltage level, select the DC voltage function (**FUNCTION DC**) and then set the offset voltage (**VOLTage:OFFSet**). Valid values are between  $\pm 5$  VDC into 50  $\Omega$  or  $\pm 10$  VDC into an open circuit. While the instrument is in DC mode, setting amplitude has no effect.

```
[SOURce[1|2]:]VOLTage:COUPlE[:STATe] ON|1|OFF|0
[SOURce[1|2]:]VOLTage:COUPlE[:STATe]?
```

Enables or disables the maintaining of the same amplitude, offset, range, load, and units on both channels of a two-channel instrument. The command applies to both channels; the SOURce keyword is ignored.

Parameter	Typical Return
ON 1 OFF 0 Default OFF	0 (OFF) or 1 (ON)
Enable voltage coupling: <b>VOLT:COUP ON</b>	

[SOURce[1|2]:]VOLTage:HIGH <voltage>|MINimum|MAXimum|DEFault  
[SOURce[1|2]:]VOLTage:HIGH? [MINimum|MAXimum]  
[SOURce[1|2]:]VOLTage:LOW <voltage>|MINimum|MAXimum|DEFault  
[SOURce[1|2]:]VOLTage:LOW? [MINimum|MAXimum]

Set the waveform's high and low voltage levels.

Parameter	Typical Return
±5 VDC into 50 Ω, as long as HIGH is at least 1 mV greater than LOW. Defaults: HIGH +50 mV, LOW -50 mV.	+4.000000000000000E+00
Set high voltage level to 4 V: VOLT:HIGH 4	

#### Remarks

- *Limits Due to Amplitude:* You can set the voltage levels to a positive or negative value with the restrictions shown below. Vpp is the maximum peak-to-peak amplitude for the selected output termination (10 Vpp into 50 Ω or 20 Vpp into an open circuit).

$$V_{\text{high}} - V_{\text{low}} \leq V_{\text{pp}} (\text{max}) \text{ and } V_{\text{high}}, V_{\text{low}} \leq V_{\text{pp}} (\text{max})/2$$

- *Differences between remote and front panel operation:*
  - **Remote Interface:** Setting the high or low level from the remote interface can change the high level or low level to achieve the desired setting. In this case either a "Data out of range" or "Settings conflict" error will occur. If the high level is set below the low level, the instrument will set the low level 1 mV less than the high level. If the high level is set below the LOW limit or the instrument output specifications, the low level will be set to the LOW limit or instrument output specification and the high level will be set 1 mV above the low level. A similar set of rules applies if the low level is set incorrectly.
  - **Front Panel:** Setting the high or low level from the front panel may clip that level setting in order to achieve the desired level setting, and a "Data out of range" error will be generated. The high level cannot be set below the low level from the front panel.
- Setting the high and low levels also sets the waveform amplitude and offset. For example, if you set the high level to +2 V and the low level to -3 V, the resulting amplitude is 5 Vpp, with a -500 mV offset.
- *Limits Due to Output Termination:* If the amplitude is 10 Vpp and you change the output termination setting from 50 Ω to "high impedance" (**OUTPut[1|2]:LOAD INF**), the displayed amplitude doubles to 20 Vpp. Changing from "high impedance" to 50 Ω halves the displayed amplitude. The output termination setting does not affect the actual output voltage; it only changes the values displayed and queried from the remote interface. Actual output voltage depends on the connected load.
- *Limits due to VOLTage:LIMit:STATe:* If voltage limits are enabled, the level settings are checked against the specified limits (**VOLTage:LIMit:HIGH**, **VOLTage:LIMit:LOW**) before a level change is executed. If an output level change would exceed a LIMIT setting, the level is clipped to the maximum (or minimum) value allowed that will not exceed the LIMit setting and a "Settings conflict" error will be generated.

- *Limits due to Output Coupling:* If two channels are coupled, limitations are checked on both channels before a change in level is executed. If a change in level would exceed a LIMIT setting or exceed the instrument's output specifications for either channel, the level is clipped to the maximum (or minimum) value allowed that will not exceed the LIMit setting and a "Settings conflict" error will be generated.
- To invert the waveform relative to the offset voltage, use **OUTPut[1|2]:POLarity**.

```
[SOURce[1|2]:]VOLTage:LIMit:HIGH <voltage>|MINimum|MAXimum|DEFault
[SOURce[1|2]:]VOLTage:LIMit:HIGH? [MINimum|MAXimum]
[SOURce[1|2]:]VOLTage:LIMit:LOW <voltage>|MINimum|MAXimum|DEFault
[SOURce[1|2]:]VOLTage:LIMit:LOW? [MINimum|MAXimum]
```

Sets the high and low limits for output voltage.

Parameter	Typical Return
±5 VDC into 50 Ω, as long as HIGH is at least 1 mV greater than LOW. Defaults: HIGH +50 mV, LOW -50 mV.	+5.00000000000000E+00
Set channel 1 output high limit to 5 V: <b>VOLT:LIMIT:HIGH 5.0</b> VOLT:LIMIT:STATE ON	

**Remarks**

- For voltage limits to be in effect, **VOLTage:LIMit:STATE** must be ON. If this is the case, and the high limit is set below the high value of the signal or the low limit is set above the low value of the signal, the relevant limit will be clipped to the high or low value of the signal. The instrument will generate either a "Data out of range" or "Settings conflict" error.
- The high limit sets the highest output voltage allowed to be set, including DC Offset and peak amplitude. It is set in reference to the current **OUTPUT[1|2]:LOAD** setting. If the specified LOAD impedance is not present at the instrument's output, then the output limit may not represent the actual voltages at the output connector. For example, if the output impedance is set to 50 Ω, but the actual load is high impedance, then the actual output peak voltage may be up to twice the specified limit voltage.
- *Specifying Voltage Units:* You can set the output limit voltage only in volts.
- When **VOLTage:COUple[:]STATE** is ON, and **VOLTage:LIMit:STATE** is ON, voltage limit settings on both channels affect maximum amplitude and offset voltage settings on both channels. The most restrictive combination of high and low limits from either channel is used.

[SOURce[1|2]:]VOLTage:LIMit:STATe ON|1|OFF|0  
[SOURce[1|2]:]VOLTage:LIMit:STATe?

Enables or disables output amplitude voltage limits.

Parameter	Typical Return
ON 1 OFF 0 Default OFF	0 (OFF) or 1 (ON)
Set and enable $\pm 2.5$ V output limits on channel 1: VOLT:LIM:HIGH 2.5 VOLT:LIM:LOW -2.5 VOLT:LIM:STAT ON	

#### Remarks

- When this is turned ON, if the present settings of amplitude and offset exceed the limits, then the limits will be disabled. The instrument will generate either a "Settings conflict" error.
- When **VOLTage:COUple[:STATe]** is ON, and **VOLTage:LIMit:STATe** is ON, voltage limit settings on both channels affect maximum amplitude and offset voltage settings on both channels. The most restrictive combination of high and low limits from either channel is used.
- Limits are set in reference to the current setting of **OUTPut[1|2]:LOAD**. If the specified LOAD impedance is not present at the instrument's output, then the output limit may not represent the actual voltages at the output connector. For example, if the output impedance is set to 50  $\Omega$ , but the actual load is high impedance, then the actual output peak voltage may be up to twice the specified limit voltage.



[SOURce[1|2]:]VOLTage:OFFSet <offset>|MINimum|MAXimum|DEFault  
[SOURce[1|2]:]VOLTage:OFFSet? [MINimum|MAXimum]

Sets DC offset voltage.

Parameter	Typical Return
± 5 VDC into 50 Ω Default 0	+1.00000000000000E-01
Set offset voltage to 100 mV: VOLT:OFFS 100 mV	

#### Remarks

- *The relationship between offset voltage and output amplitude is shown below.*  
  

$$|V_{offset}| < V_{max} - V_{pp}/2$$
- *Differences between remote and front panel operation:*
  - **Remote Interface:** Setting the offset from the remote interface can change the amplitude in order to achieve the desired offset setting. The instrument will generate either a "Data out of range" or "Settings conflict" error.
  - **Front Panel:** Setting the offset from the front panel will not change the amplitude in order to achieve the desired offset setting. If the specified offset is not valid, the instrument will clip it to the maximum offset allowed with the current amplitude and generate a "Data out of range" error.
- **Limits Due to Output Termination:** The offset range depends on the output termination setting. For example, if you set offset to 100 mVDC and then change output termination from 50 Ω to "high impedance," the offset voltage displayed on the front panel doubles to 200 mVDC (no error is generated). If you change from "high impedance" to 50 Ω, the displayed offset voltage will be halved. See **OUTPut[1|2]:LOAD** for details. Changing the output termination setting does not change the voltage present at the output terminals of the instrument. This only changes the displayed values on the front panel and the values queried from the remote interface. The voltage present at the instrument's output depends on the load connected to the instrument. See **OUTPut [1|2]:LOAD** for details.
- **Limits due to Output Coupling:** If two channels are coupled, limitations of setting offset will be checked on both channels before a change in offset is executed. If a change in offset would exceed a LIMIT setting, or exceed the instrument's output specifications for either channel:
  - *Remote Interface:* First the amplitude and then if necessary, the offset of that channel will be adjusted to comply with the voltage limits or specification. The instrument will generate either a "Data out of range" or "Settings conflict" error.
  - *Front panel:* The offset value is clipped to the maximum value allowed that will not exceed the LIMit setting, and a "Data out of range" error will be generated.
- **Arbitrary Waveform Limitations:** For arbitrary waveforms, amplitude is limited if the waveform data points do not span the full range of the output DAC (Digital-to-Analog Converter). For example, the built-in "Sinc" waveform does not use the full range of values, so its maximum amplitude is limited to 6.087 Vpp (into 50 Ω).

- Changing amplitude may briefly disrupt output at certain voltages due to output attenuator switching. The amplitude is controlled, however, so the output voltage will never exceed the current setting while switching ranges. To prevent this disruption, disable voltage autoranging using **VOLTage:RANGe:AUTO OFF**. The **APPLy** command automatically enables autoranging.
- Setting the high and low levels also sets the waveform amplitude and offset. For example, if you set the high level to +2 V and the low level to -3 V, the resulting amplitude is 5 Vpp, with a -500 mV offset.
- To output a DC voltage level, select the DC voltage function (**FUNction DC**) and then set the offset voltage (**VOLTage:OFFSet**). Valid values are between  $\pm 5$  VDC into 50  $\Omega$  or  $\pm 10$  VDC into an open circuit. While the instrument is in DC mode, setting amplitude has no effect.

```
[SOURce[1|2]:]VOLTage:RANGe:AUTO OFF|0|ON|1|ONCE
[SOURce[1|2]:]VOLTage:RANGe:AUTO?
```

Disables or enables voltage autoranging for all functions. Selecting ONCE performs an immediate autorange and then turns autoranging OFF

Parameter	Typical Return
OFF 0 ON 1 ONCE Default ON	0 (OFF) or 1 (ON)
Turn voltage autoranging OFF: VOLT:RANG:AUTO 0	

**Remarks**

- In the default mode, autoranging is enabled and the instrument automatically selects the optimal settings for the output waveform generator and attenuator.
- With autoranging disabled (OFF), the instrument uses the instrument's current gain and attenuator settings.
- The **APPLy** command overrides the voltage autorange setting and automatically enables autoranging (ON).
- Disabling autoranging eliminates momentary disruptions caused by attenuator switching while changing amplitude. However, the amplitude and offset accuracy and resolution (and waveform fidelity) may be adversely affected when reducing the amplitude below the expected range change.
- If a **VOLTage:COUPlE[:STATe]** is ON, changing this setting on either channel changes it on both.

[SOURce[1|2]:]VOLTage:UNIT VPP|VRMS|DBM  
[SOURce[1|2]:]VOLTage:UNIT?

Selects the units for output amplitude.

Parameter	Typical Return
VPP VRMS DBM Default VPP	VPP, VRMS, or DBM
Set output amplitude units to Vrms: VOLT:UNIT VRMS	

#### Remarks

- Does not affect offset voltage (VOLTage:OFFSet), high level (VOLTage:HIGH) or low level (VOLTage:LOW). They all use units of volts.
- The instrument uses the current units selection for both front panel and remote interface operations. For example, if you select "VRMS" from the remote interface (VOLTage:UNIT VRMS), the units are displayed as "VRMS" on the front panel.
- Command applies to VOLTage? query results.
- Output units for amplitude cannot be set to dBm if the output termination is set to "high impedance." The units are automatically converted to Vpp.
- Unless you specify the units as part of either the VOLTage command or one of the **APPLY** commands, the VOLTage:UNIT command takes precedence. For example, if you select VOLTage:UNIT VRMS and do not include units with an **APPLY** command, the *<amplitude>* in the **APPLY** command will be in "Vrms".

## STATus Subsystem

The instrument's SCPI status system records various instrument conditions and states in several register groups.

In this subsystem, an event is something that occurred, even though it may not still be occurring. A condition is something that is currently present. A condition will appear in the event register, but the event register is read destructive; it is cleared (set to 0) when read.

The **STATus commands** manipulate bits in two of the enable registers. You can:

- Enable bits in the **Questionable Data enable** register (**STATus:QUESTIONable:ENABLE <enable\_value>**). Query: **STATus:QUESTIONable:ENABLE?**
- Enable bits in the **Operation enable** register (**STATus:OPERation:ENABLE <enable\_value>**). Query: **STATus:OPERation:ENABLE?**
- Clear all bits in the **Questionable Data** enable register and the Standard Operation enable register (**STATus:PRESet**).

The **STATus queries** accesses information about the status bits in the **Questionable Data** registers, including:

- The binary-weighted sum of all bits enabled in the Questionable Data **condition** register (**STATus:QUESTIONable:CONDition?**)
- The binary-weighted sum of all bits enabled in the Questionable Data **event** register (**STATus:QUESTIONable[:EVENT]?**)
- The binary-weighted sum of all bits enabled in the Questionable Data **enable** register (**STATus:QUESTIONable:ENABLE <enable\_value>**).

The **STATus queries** also allow you to access information about the status bits in the **Operation** registers, including:

- The binary-weighted sum of all bits enabled in the Operation **condition** register (**STATus:OPERation:CONDition?**).
- The binary-weighted sum of all bits enabled in the Operation **event** register (**STATus:OPERation[:EVENT]?**).

## STATus:OPERation:CONDition?

Queries the condition register for the **Standard Operation Register** group. Register is read-only; bits not cleared when read.

Parameter	Typical Return
(none)	+32
Read the condition register (bit 5 is set): STAT:OPER:COND?	

### Remarks

- The condition register bits reflect the current condition. If a condition goes away, the corresponding bit is cleared .
- **\*RST** clears this register, other than those bits where the condition still exists after \*RST.
- The command reads the condition register and returns a decimal value equal to the binary-weighted sum of all bits set in the register. For example, if bit 5 (decimal value = 32) and bit 9 (decimal value = 512) are set, the command will return +544.

## STATus:OPERation:ENABLE <enable\_value>

### STATus:OPERation:ENABLE?

Enables bits in the **enable register** for the **Standard Operation Register** group. The selected bits are then reported to the Status Byte as the standard operation summary bit.

Parameter	Typical Return
Sum of the bits' decimal values in the register.	+256
Enable bit 8 (decimal value 256) in the enable register: STAT:OPER:ENAB 256	

### Remarks

- Use <enable\_value> to specify which bits are reported to the Status Byte. The specified value corresponds to the binary-weighted sum of the register bits to enable. For example, to enable bit 5 (value 32) and bit 9 (value 512), the decimal value would be 544.
- **\*CLS** does not clear the enable register, but does clear the event register.
- This register is cleared at power-on unless **\*PSC** is set to 0.

### See Also

- **\*STB?**

## STATus:OPERation[:EVENT]?

Queries the event register for the **Standard Operation Register** group. This is a read-only register; the bits are cleared when you read the register.

Parameter	Typical Return
(none)	+32

---

Read event register:  
STAT:OPER:EVENT?

---

### Remarks

- A set bit remains set until cleared by reading the event register or **\*CLS**.
- **\*RST** does not affect this register.
- Query reads the event register and returns a decimal value equal to the binary-weighted sum of all bits set in the register. For example, if bit 5 (value 32) and bit 9 (value 512) are set, the command returns +544.

## STATus:PRESet

Clears **Questionable Data** enable register and **Standard Operation** enable register.

Parameter	Typical Return
(none)	(none)

---

Clear enable register bits:  
STAT:PRESet

---

## STATus:QUEStionable:CONDition?

Queries the condition register for the **Questionable Data Register** group.

Parameter	Typical Return
(none)	+512
Read the condition register (bit 9 is set): STAT:QUES:COND?	

### Remarks

- The Questionable Data register group provides information about the instrument's quality or integrity.
- Any or all conditions can be reported to the Questionable Data summary bit through the enable register.
- Register is read-only; bits not cleared when read.
- The condition register bits reflect the current condition. If a condition goes away, the corresponding bit is cleared.
- **\*RST** clears the condition register.
- The query reads the condition register and returns a decimal value equal to the binary-weighted sum of all bits set in the register. For example, if bit 12 (decimal value = 4096) is set, the query returns "+4096".

STATus:QUESTionable:ENABLE <enable\_value>  
STATus:QUESTionable:ENABLE?

Enables bits in the **enable register** for the **Questionable Data Register** group. The selected bits are then reported to the Status Byte.

Parameter	Typical Return
Decimal value equal to the sum of the bit decimal values in the register.	+512
Enable bit 9 (value 512) in the enable register: STAT:QUES:ENAB 512	

#### Remarks

- Use <enable\_value> to specify which bits are reported to the Status Byte. The specified value corresponds to the binary-weighted sum of the register bits to enable. For example, to enable bit 5 (value 32) and bit 9 (value 512), the decimal value would be 544.
- Enable register cleared by:
  - STATus:Questionable:ENABLE 0
  - **STATus:PRESet**
  - Power cycle (unless **\*PSC** is set to 0)
- **\*CLS** does not clear enable register but it does clear event register.
- **\*RST** does not affect this register.
- The Query reads the enable register and returns a decimal value equal to the binary-weighted sum of all bits set in the register. For example, if bit 0 (value 1) and bit 1 (value 2) are enabled, the query returns +3.

STATus:QUESTionable[:EVENT]?

Queries the event register for the **Questionable Data Register** group. This is a read-only register; the bits are cleared when you read the register.

Parameter	Typical Return
(none)	+512
Read the event register (bit 9 set): STAT:QUES?	

#### Remarks

- Once a bit is set, it remains set until cleared by this query or **\*CLS**.
- **\*RST**, **STATus:PRESet**, and **\*PSC** have no effect on this register.
- Query reads the event register and returns a decimal value equal to the binary-weighted sum of all bits set in the register. For example, if bit 1 (value 2) and bit 9 (value 512) are set, the query returns "+514".



## SYSTEM Subsystem

The SYSTEM subsystem manages instrument state storage, power-down recall, error conditions, self test, front panel display control and remote interface configuration.

### NOTE

The instrument uses LAN port 5024 for SCPI Telnet sessions, and port 5025 for SCPI Socket sessions.

---

- **SYSTEM:BEEPPer[:IMMEDIATE]** - issues a single beep
- **SYSTEM:BEEPPer:STATE ON|1|OFF|0** - disables or enables beeper
- **SYSTEM:CLICK:STATE** - disables or enables keypress click
- **SYSTEM:COMMunicate:LAN:CONTRol?** - reads and returns the control connection port number for Socket communications
- **SYSTEM:COMMunicate:LAN:DHCP ON|OFF|1|0** - enables or disables the use of the DHCP for the instrument
- **SYSTEM:COMMunicate:LAN:DNS[1 | 2] "<address>"** - assigns static IP addresses of DNS servers
- **SYSTEM:COMMunicate:LAN:DOMain?** - returns the current network domain name
- **SYSTEM:COMMunicate:LAN:GATEway "<address>"** - assigns a default gateway for the instrument
- **SYSTEM:COMMunicate:LAN:HOSTname "<name>"** - assigns a hostname to the instrument
- **SYSTEM:COMMunicate:LAN:IPADdress "<address>"** - assigns a static IP address for the instrument
- **SYSTEM:COMMunicate:LAN:MAC?** - returns the instrument's MAC address
- **SYSTEM:COMMunicate:LAN:SMASk "<mask>"** - assigns a subnet mask for the instrument to use
- **SYSTEM:COMMunicate:LAN:TELNet:PRoMpt "<string>"** - sets the command prompt
- **SYSTEM:COMMunicate:LAN:TELNet:WMESsage "<string>"** - sets the welcome message
- **SYSTEM:COMMunicate:LAN:UPDate** - updates any changes made to the LAN settings
- **SYSTEM:COMMunicate:TCPIp:CONTRol?** - returns the initial socket control connection port number
- **SYSTEM:DATE <yyyy>,<mm>,<dd>** - sets system clock date
- **SYSTEM:ERRor?** - reads and clears one error from error queue
- **SYSTEM:SET <block\_data>** - sets the instrument state
- **SYSTEM:TIME <hh>,<mm>,<ss>** - sets system clock time
- **SYSTEM:VERSion?** - returns version of SCPI used by instrument

SYSTem:BEEPer[:IMMEDIATE]

Issues a single beep.

Parameter	Typical Return
(none)	(none)

Issue a single beep:  
SYST:BEEP

**Remarks**

- Sending a programmed beep may be useful for program development and troubleshooting.
- This command overrides the current beeper state (the SYSTem:BEEPer:STATe ). This means that you can issue a single beep even if the beeper is turned off.

SYSTem:BEEPer:STATe ON|1|OFF|0

SYSTem:BEEPer:STATe?

Disables or enables the beeper tone heard when an error is generated from the front panel or remote interface.

Parameter	Typical Return
ON 1 OFF 0 Default ON	0 (OFF) or 1 (ON)

Disable beeper state:  
SYST:BEEP:STAT OFF

**Remarks**

- Turning off the beeper does not disable the front panel key click.
- A beep is always emitted (even with beep state OFF) when **SYSTem:BEEPer** is sent.
- This setting is non-volatile; it will not be changed by power cycling or **\*RST**.

SYSTem:CLICk:STATeON|1|OFF|0  
SYSTem:CLICk:STATe?

Disables or enables the click heard when a front panel key or softkey is pressed.

Parameter	Typical Return
ON 1 OFF 0 Default ON	0 (OFF) or 1 (ON)
Disable keyboard click: SYST:CLIC:STAT OFF	

**Remarks**

- This command does not affect the beeper that indicates errors.
- This setting is non-volatile; it will not be changed by power cycling or **\*RST**.

SYSTem:COMMunicate:LAN:CONTRol?

Reads and returns the control connection port number for Socket communications. Connection is used to send and receive commands and queries. If 0 is returned, the interface does not support a Socket Control connection.

Parameter	Typical return
(none)	+5000 (0 if the interface does not support sockets)
Returns the control connection port number: SYST:COMM:LAN:CONT?	

**Remarks**

- This query is only used when programming over Sockets.
- You can use the Socket Control connection to send a Device Clear to the instrument or to detect pending Service Request (SRQ) events.

SYSTem:COMMunicate:LAN:DHCP ON|1|OFF|0  
SYSTem:COMMunicate:LAN:DHCP?

Enables (On) or disables (Off) the use of the Dynamic Host Configuration Protocol (DHCP) for the instrument.

ON: The instrument will try to obtain an IP address from a DHCP server. If a DHCP server is found, it will assign a dynamic IP address, Subnet Mask, and Default Gateway to the instrument. If a DHCP server is not found, the instrument uses AutoIP to automatically configure its IP setting in the Automatic Private IP Addressing range (169.254.xxx.xxx).

OFF: The instrument will use the static IP address, Subnet Mask, and Default Gateway during power-on.

**NOTE**

If you change this setting, you must execute a **SYSTem:COMMunicate:LAN:UPDate** command to activate the setting.

Parameter	Typical return
ON 1 OFF 0	0 or 1
Disables DHCP: SYST:COMM:LAN:DHCP OFF SYST:COMM:LAN:UPD	

**Remarks**

- Most site LANs have a DHCP server.
- If a DHCP LAN address is not assigned by a DHCP server, then an AutoIP address static IP will be assumed after approximately two minutes.
- The DHCP setting is stored in non-volatile memory, and does not change when power has been off, after a Factory Reset (**\*RST**).

```
SYSTem:COMMunicate:LAN:DNS[1 | 2] "<address>"
SYSTem:COMMunicate:LAN:DNS[1 | 2]? [CURRent|STATic]
```

Assigns static IP addresses of Domain Name System (DNS) servers. A primary and a secondary server address () may be assigned. If DHCP is available and enabled, DHCP will auto-assign these server addresses. These auto-assigned server addresses take precedence over the static addresses assigned with this command. Contact your LAN administrator for details.

## NOTE

If you change this setting, you must execute a **SYSTem:COMMunicate:LAN:UPDate** command to activate the setting.

Parameter	Typical return
<address>: Four-byte dot notation ("nnn.nnn.nnn.nnn"), where "nnn" in each case is a byte value in the range of 0 through 255.	"198.105.232.4"
[CURRent STATic] Default CURRent	
Set a static primary DNS address: SYST:COMM:LAN:DNS "198.105.232.4" SYST:COMM:LAN:UPD	

- **CURRent** - Returns address currently being used by the instrument.
- **STATIC** - Returns address from non-volatile memory. This address is used if DHCP is disabled or unavailable.
- The assigned DNS address is used for the DNS server if DHCP is disabled. Otherwise, the DNS server address is auto-assigned by DHCP.
- The setting is non-volatile, and does not change when power has been off or after a Factory Reset (**\*RST** command).

```
SYSTem:COMMunicate:LAN:DOMain?
```

Reads the current network domain name and returns an ASCII string enclosed in double quotes.

Parameter	Typical return
(none)	"example.com"
Returns the domain name being used by the instrument: SYST:COMM:LAM:DOM?	

## Remarks

- If Dynamic Domain Name System (DNS) is available on your network and your instrument uses DHCP, the domain name is assigned by the Dynamic DNS service at power-on.
- If a domain name has not been assigned, a null string ( " " ) is returned.

SYSTem:COMMunicate:LAN:GATEway "<address>"  
SYSTem:COMMunicate:LAN:GATEway? [CURRent|STATic]

Assigns a default gateway for the instrument. The specified IP Address sets the default gateway, which allows the instrument to communicate with systems that are not on the local subnet. Thus, this is the default gateway where packets are sent that are destined for a device not on the local subnet, as determined by the Subnet Mask setting. Contact your LAN administrator for details.

**NOTE**

If you change this setting, you must execute a **SYSTem:COMMunicate:LAN:UPDate** command to activate the setting.

Parameter	Typical return
<address>: Four-byte dot notation ("nnn.nnn.nnn.nnn"), where "nnn" in each case is a byte value in the range of 0 through 255.	"198.105.232.4"
[CURRent STATic] Default CURRent	
Set a default gateway address: SYST:COMM:LAN:GATE "198.105.232.4" SYST:COMM:LAN:UPD	

**Remarks**

- **CURRent** - Returns address currently being used by the instrument.
- **STATic** - Returns address from non-volatile memory. This address is used if DHCP is disabled or unavailable.
- If DHCP is enabled (**SYSTem:COMMunicate:LAN:DHCP ON** command), the specified default gateway is not used. However, if the DHCP server fails to assign a valid IP address, the currently configured default gateway is used.
- The setting is non-volatile, and does not change when power has been off or after a Factory Reset (**\*RST** command).
- A gateway value of "0.0.0.0" indicates that subnetting is not being used.

SYSTem:COMMunicate:LAN:HOSTname "<name>"  
SYSTem:COMMunicate:LAN:HOSTname? [CURRent|STATic]

Assigns a hostname to the instrument. A hostname is the host portion of the domain name, which is translated into an IP address. If Dynamic Domain Name System (Dynamic DNS) is available on your network and your instrument uses DHCP, the hostname is registered with the Dynamic DNS service at power-on. If DHCP is enabled (**SYSTem:COMMunicate:LAN:DHCP ON**), the DHCP server can change the specified hostname.

#### NOTE

If you change this setting, you must execute a **SYSTem:COMMunicate:LAN:UPDate** command to activate the setting.

Parameter	Typical return
<name>: A string of up to 15 characters. Must start with letter (A-Z) May contain letters, numbers (0-9), or dashes ("-") Default: "K-<instrument model number>-nnnnn", where "nnnnn" is the last five digits of the instrument's serial number.	"LAB1-EDU3321xA"
[CURRent STATic] Default: CURRent	
Define a hostname: SYST:COMM:LAN:HOST "LAB1-EDU33211A" SYST:COMM:LAN:UPD	

#### Remarks

- **CURRent** - Returns hostname currently being used by the instrument.
- **STATic** - Returns desired hostname from non-volatile memory, that may not be the actual name used by the instrument if DHCP is enabled.
- If host name has not been assigned, the query returns a null string ("").
- The setting is non-volatile, and does not change when power has been off or after a Factory Reset (**\*RST** command).

```
SYSTem:COMMunicate:LAN:IPADdress "<address>"  
SYSTem:COMMunicate:LAN:IPADdress? [CURRent|STATic]
```

Assigns a static Internet Protocol (IP) address for the instrument. If DHCP is enabled (**SYSTem:COMMunicate:LAN:DHCP ON**), the specified static IP address is not used. Contact your LAN administrator for details.

#### NOTE

If you change this setting, you must execute a **SYSTem:COMMunicate:LAN:UPDate** command to activate the setting.

---

Parameter	Typical return
<address>: Four-byte dot notation ("nnn.nnn.nnn.nnn"), where "nnn" in each case is a byte value in the range 0 through 255.	"198.105.232.4"
[CURRent STATic] Default: CURRent	
Sets a static IP address: SYST:COMM:LAN:IPAD "198.105.232.4" SYST:COMM:LAN:UPD	

---

#### Remarks

- **CURRent** - Returns address currently being used by the instrument.
- **STATic** - Returns static address from non-volatile memory. This address is used if DHCP is disabled or unavailable.
- The setting is non-volatile, and does not change when power has been off or after a Factory Reset (**\*RST** command).



## SYSTem:COMMunicate:LAN:MAC?

Returns the instrument's Media Access Control (MAC) address as an ASCII string of 12 hexadecimal characters (0-9 and A-F) enclosed in quotation marks.

### NOTE

Your network administrator may need the instrument's MAC address in order to assign a static IP address for this device.

---

Parameter	Typical return
(none)	"80:09:02:00:10:41"

Returns the MAC address:  
SYST:COMM:LAN:MAC?

---

### Remarks

- Query reads the MAC address and returns an ASCII string enclosed in double quotes.
- The instrument's MAC address is unique to the instrument. It is set at the factory and cannot be changed.
- The setting is non-volatile, and does not change when power has been off or after a Factory Reset (**\*RST** command).
- MAC address also known as the link-layer address, the Ethernet (station) address, LANIC ID, or Hardware Address. This is an unchangeable 48-bit address assigned by the manufacturer to each unique Internet device.

SYSTem:COMMunicate:LAN:SMASk "<mask>"  
SYSTem:COMMunicate:LAN:SMASk? [CURRent|STATic]

Assigns a subnet mask for the instrument to use in determining whether a client IP address is on the same local subnet. When a client IP address is on a different subnet, all packets must be sent to the Default Gateway. Contact your LAN administrator for details.

**NOTE**

If you change this setting, you must execute a **SYSTem:COMMunicate:LAN:UPDate** command to activate the setting.

Parameter	Typical return
<mask>	Four-byte dot notation ("nnn.nnn.nnn.nnn"), where "198.105.232.4" "nnn" in each case is a byte value in the range 0 through 255. Default: "255.255.0.0"
[CURRent STATic]	Default: CURRent
Sets the subnet mask: SYST:COMM:LAN:SMAS "255.255.254.0" SYST:COMM:LAN:UPDate	

**Remarks**

- **CURRent** - Returns subnet mask currently being used by the instrument.
- **STATic** - Returns subnet mask from non-volatile memory. This address is used if DHCP is disabled or unavailable.
- A value of "0.0.0.0" or "255.255.255.255" indicates that subnetting is not being used.
- The setting is non-volatile, and does not change when power has been off or after a Factory Reset (**\*RST** command).

SYSTem:COMMunicate:LAN:TELNet:PROMpt "<string>"  
SYSTem:COMMunicate:LAN:TELNet:PROMpt?

Sets the command prompt displayed when communicating the instrument with Telnet.

Parameter	Typical return
<string>: A string of up to 15 characters	"Command"
Defines the command prompt: SYST:COMM:LAN:TELN:PROM "Command"	

**Remarks**

- Query returns the command prompt as ASCII strings enclosed in double quotes.
- Instrument uses LAN port 5024 for SCPI Telnet sessions, and port 5025 for SCPI Socket sessions.
- Telnet port is an alternate way to send SCPI commands to the instrument.
- Telnet session can typically be started as follows from a host computer shell:  
telnet <IP\_address> <port>

For example:

```
telnet 169.254.4.10 5024
```

To exit a Telnet session, press <Ctrl-D>.

- The setting is non-volatile, and does not change when power has been off or after a Factory Reset (**\*RST** command).

```
SYSTem:COMMunicate:LAN:TELNet:WMESsage "<string>"  
SYSTem:COMMunicate:LAN:TELNet:WMESsage?
```

Sets the welcome message displayed when communicating the instrument with Telnet.

Parameter	Typical return
<string>: A string of up to 63 characters Default: "Welcome to Keysight's <instrument model number> Arbitrary Waveform Generator"	"Welcome to the Telnet Session"
Define a welcome message: SYST:COMM:LAN:TELN:WMES "Welcome to the Telnet Session"	

#### Remarks

- Query returns the command prompt as ASCII strings enclosed in double quotes.
- Instrument uses LAN port 5024 for SCPI Telnet sessions and port 5025 for SCPI Socket sessions.
- The setting is non-volatile, and does not change when power has been off or after a Factory Reset (**\*RST** command).

## SYSTem:COMMunicate:LAN:UPDate

Stores any changes made to the LAN settings into non-volatile memory and restarts the LAN driver with the updated settings.

Parameter	Typical return
(none)	(none)
Configures the instrument to use statically assigned LAN settings (disables DHCP): SYST:COMM:LAN:DHCP OFF SYST:COMM:LAN:DNS "198.105.232.4" SYST:COMM:LAN:DNS2 "198.105.232.5" SYST:COMM:LAN:GAT "198.105.232.1" SYST:COMM:LAN:HOST "LAB1-EDU33210A" SYST:COMM:LAN:IPAD "198.105.232.101" SYST:COMM:LAN:UPD	
Configures the instrument back to use DHCP (enables DHCP): SYST:COMM:LAN:DHCP OFF SYST:COMM:LAN:UPD	

### Remarks

- Be very careful when you execute this command, because your instrument may not work on the LAN if you update the instrument with invalid LAN settings.
- If your instrument does not work after you execute this command, perform the LAN Reset through instrument's front panel softkey to restore the settings to reset values and reset the LAN, or use another I/O interface, such as USB, to correct the settings.
- This command must be sent after changing the settings for DHCP, DNS, gateway, hostname, IP address, or sub-net mask.

## SYSTem:COMMunicate:TCPIP:CONTRol?

Returns the initial socket control connection port number. After the control port number is obtained, a control socket connection can be opened.

Parameter	Typical return
(none)	+5000 (0 if the interface does not support sockets)
Queries the Control connection port number: SYST:COMM:TCP:CONT?	

### NOTE

The control socket connection can only be used by a client to send a device clear to the instrument or to detect Service Request (SRQ) events.

Refer to "Using Sockets" in the *User's Guide* for more information.

SYSTem:DATE <yyyy>,<mm>,<dd>  
SYSTem:DATE?

Sets system clock date.

Parameter	Typical Return
<yyyy> 2000 to 2099 <mm> 1 to 12 <dd> 1 to 31	+2011,+7,+26
Set system date to July 26, 2011: SYST:DATE 2011,7,26	

SYSTem:ERRor?

Reads and clears one error from error queue.

Parameter	Typical Return
(none)	-113,"Undefined header"
Read and clear first error in error queue: SYST:ERR?	

#### Remarks

- Up to 20 command syntax or hardware errors can be stored in a single error queue for all interfaces (USB, VXI-11, and Telnet/sockets).
- Error retrieval is first-in-first-out (FIFO), and errors are cleared as you read them. The instrument beeps once each time an error is generated (unless disabled by **SYSTem:BEEPer:STATe OFF**).
- If more than 20 errors have occurred, the last error stored in the queue (the most recent error) is replaced with -350,"Error queue overflow". No additional errors are stored until you remove errors from the queue. If no errors have occurred when you read the error queue, the instrument responds with +0,"No error".
- The error queue is cleared by the \*CLS and when power is cycled. It is not cleared by \*RST.
- Errors have the following format (the error string may contain up to 255 characters).  
<error code>,<error string>

Where:

<error code> = a three-digit code, sometimes preceded by a dash

<error string> = a quoted ASCII string up to 255 characters

SYSTem:SET <block\_data>  
SYSTem:SET?

Sets the instrument state as defined by the data returned by SYSTem:SET? query.

Parameter	Typical return
<block_data>: The block data returned by SYSTem:SET? query.	#nN<instrument state> where the first digit after the # indicates the number of following digits. The following digits indicate the length of the data.

SYSTem:TIME <hh>,<mm>,<ss>  
SYSTem:TIME?

Sets system clock time.

Parameter	Typical Return
<hh> 0 to 23 <mm> 0 to 59 <ss> 0 to 59	20,15,30.000
Set system Time to 20:15:30 (8:15:30 PM): SYST:TIME 20,15,30	

**Remarks**

- This time is used for file timestamps in the Mass Memory (MMEMory) system.

SYSTem:VERSion?

Returns version of the SCPI (Standard Commands for Programmable Instruments) that the instrument complies with. Cannot be determined from front panel.

Parameter	Typical Return
(none)	1994.0
Return the SCPI version: SYST:VERS?	

## TRIGger Subsystem

Configures triggering for list, burst, and sweep.

### Command Summary

- **TRIGger[1|2]** - Immediate trigger
- **TRIGger[1|2]:COUNT** <number>**MINimum|MAXimum|DEFAULT** - Trigger count
- **TRIGger[1|2]:DELAY** <seconds>**MINimum|MAXimum|DEFAULT** - Trigger delay
- **TRIGger[1|2]:SLOPe** **POSitive|NEGative** - Slope of trigger signal at the front-panel **Ext Trig** connector
- **TRIGger[1|2]:SOURce** **IMMediate|EXTernal|TIMer|BUS** - Source (internal, external, timer, or bus) from which instrument accepts trigger
- **TRIGger[1|2]:TIMer** <seconds>**MINimum|MAXimum|DEFAULT** - Timer used when **TRIGger[1|2]:SOURce** is **TIMer**.



## TRIGger[1|2]

Forces immediate trigger to initiate sweep, list, or burst.

Parameter	Typical Return
(none)	(none)

Send an immediate trigger on channel 2:  
TRIG

### Remarks

- Can be used with IMMEDIATE, EXTERNAL, TIMER, or BUS trigger source (TRIGger[1|2]:SOURCE). For example, you can use TRIGger to issue an immediate trigger while waiting for an external trigger.
- Intended as an override. For general, software controlled triggering, use \*TRG.

TRIGger[1|2]:COUNT <number>MINimum|MAXimum|DEFAULT  
TRIGger[1|2]:COUNT? [MINimum|MAXimum]

Sets trigger count.

Parameter	Typical Return
1 to 1,000,000 Default 1	10000

Set channel 2 trigger count to 10000:  
TRIG2:COUN 10000

### Remarks

- Can be used with IMMEDIATE, EXTERNAL, TIMER, or BUS trigger source (TRIGger[1|2]:SOURCE).
- Applies only when INITiate[1|2]:CONTinuous is OFF.

TRIGger[1|2]:DELAY <seconds>|MINimum|MAXimum|DEFAULT  
TRIGger[1|2]:DELAY? [MINimum|MAXimum]

Sets trigger delay, (time from assertion of trigger to occurrence of triggered event).

Parameter	Typical Return
0 to 1000 s, in resolution of 4 ns Default 0	+1.0500000000000000E-01

Set channel 1 trigger delay to 105 ms:  
TRIG:DEL 105e-3

### Remarks

- Can be used with IMMEDIATE, EXTERNAL, TIMER, or BUS trigger source (TRIGger[1|2]:SOURCE).

TRIGger[1|2]:SLOPe POSitive|NEGative  
TRIGger[1|2]:SLOPe?

Specifies polarity of trigger signal on front-panel **Trig In** connector for any externally-triggered mode.

Parameter	Typical Return
POSitive NEGative Default POS (rising edge)	POS or NEG
Set trigger slope to falling edge: TRIG:SLOP NEG	

TRIGger[1|2]:SOURce IMMEDIATE|EXTERNAL|TIMER|BUS  
 TRIGger[1|2]:SOURce?

Selects the trigger source for list, burst or sweep. The instrument accepts an immediate or timed internal trigger, an external hardware trigger from the front-panel **Ext Trig** connector, or a software (bus) trigger.

Parameter	Typical Return
IMMEDIATE EXTERNAL TIMER BUS Default IMMEDIATE	IMM, EXT, TIM, BUS
Select external trigger source (trigger each time a low-true TTL pulse is received on the front-panel trigger input): TRIG:SOUR EXT	

#### Remarks

In triggered burst mode:

- The instrument outputs a waveform of the specified number of cycles (burst count) when a trigger is received. After the specified number of cycles have been output, the instrument stops and waits for next trigger.
- **IMMEDIATE (internal)**: the instrument outputs continuously when burst mode is enabled. The rate at which the burst is generated is determined by **BURSt:INTernal:PERiod**.
- **EXTERNAL**: the instrument accepts a hardware trigger at the front-panel **Ext Trig** connector. The instrument outputs one burst of the specified number of cycles each time **Ext Trig** receives a level transition with the proper polarity (**TRIGger[1|2]:SLOPe**). External trigger signals during a burst are ignored.
- **BUS (software)**: the instrument initiates one burst each time a bus trigger (**\*TRG**) is received. The front panel **[Trigger]** key is illuminated when the instrument is waiting for a bus trigger.
- **EXTERNAL or BUS**: burst count and burst phase remain in effect, but burst period is ignored.
- **TIMER**: trigger events are spaced by a timer, with the first trigger as soon as **INIT** occurs.

In frequency sweep mode:

- **IMMEDIATE (internal)**: the instrument outputs continuously when the sweep is enabled. The period at which the sweep is generated is the sweep time (**SWEep:TIME**) plus 1 ms.
- **EXTERNAL**: the instrument accepts a hardware trigger at the front-panel **Ext Trig** connector. The instrument initiates one sweep each time **Trig In** receives a TTL pulse of proper edge polarity (**TRIGger[1|2]:SLOPe**). The trigger period must be at least sweep time (**SWEep:TIME**) plus 1 ms.
- **BUS (software)**: the instrument initiates one sweep each time a bus trigger (**\*TRG**) is received. The front panel **[Trigger]** key is illuminated when the instrument is waiting for a bus trigger.
- **APPLy** sets trigger source to IMMEDIATE.
- To ensure synchronization with BUS source, send **\*WAI** (wait) so the instrument waits for all pending operations to complete before executing any additional commands. For example, the following command string guarantees that the first trigger is accepted and the operation is executed before second trigger is recognized.

```
TRIG:SOUR BUS;*TRG;*WAI;*TRG;*WAI
```

- Use **\*OPC?** or **\*OPC** to determine when the sweep or burst is complete. The **\*OPC?** query returns 1 to the output buffer when the sweep or burst is complete. The **\*OPC** command sets the Operation Complete bit (bit 0) in the Standard Event register when the sweep or burst is complete.

```
TRIGger[1|2]:TIMer <seconds>|MINimum|MAXimum|DEFault
TRIGger[1|2]:TIMer? [MINimum|MAXimum]
```

Sets timer used when **TRIGger[1|2]:SOURce** is **TIMer**.

Parameter	Typical Return
1 $\mu$ s to 8,000 s	+3.000000000000000E-01
Set trigger timer to 300 ms on channel 2: TRIG2:TIM 0.3	

- In triggered burst mode (**BURSt:MODE TRIG**), this command supersedes **BURSt:INTernal:PERiod**.

## UNIT Subsystem

### Command Summary

- **UNIT:ANGLE**

UNIT:ANGLE DEGree|RADian|SECond|DEFault  
UNIT:ANGLE?

Specifies the angle units that displayed on the screen and used for specifying angles. The selected units are used for setting the starting phase for a burst (**BURSt:PHASe**) and for setting the phase offset (**PHASe**). The associated queries are also affected.

Parameter	Typical Return
DEGree RADian SECond DEFault Default DEGree	DEG, RAD, SEC, or DEF
Set angle units to radians:	
UNIT:ANGL RAD	

**Remarks**

- The setting may be overridden by adding units to numeric parameter in command. For example, PHASE 90 DEG specifies 90 degrees, regardless of this setting.



This information is subject to change without notice.

© Keysight Technologies 2020-2022  
Edition 2, November 2022  
Printed in Malaysia



EDU33212-90013

[www.keysight.com](http://www.keysight.com)