



Model 5170/5180
GAUSS / TESLA METER

Instruction Manual



Manual UN-01-260
Rev. E
Sypris Test & Measurement
All rights reserved.

Toll Free 800-778-6117 USA • 407-678-6900



Table of Contents

Section -1 Introduction

UNDERSTANDING FLUX DENSITY.....	1-1
MEASUREMENT OF FLUX DENSITY	1-2
PRODUCT DESCRIPTION	1-4
APPLICATIONS	1-4

Section - 2 Specifications

SPECIFICATIONS	2-1
MODEL 5170 / 5180 SPECIFICATIONS	2-2
STANDARD TRANSVERSE PROBE	2-3
STANDARD AXIAL PROBE	2-4
LOW FIELD AXIAL PROBE	2-5
ZERO FLUX CHAMBER	2-6

Section - 3 Operating Instructions

OPERATOR SAFETY	3-1
OPERATING FEATURES	3-2
INSTRUMENT PREPARATION	3-3
POWER-UP	3-4
POWER-UP SETTINGS	3-5
LOW BATTERY CONDITION	3-6
OVERRANGE CONDITION	3-6
AC OR DC MEASUREMENT SELECTION	3-6
UNITS OF MEASUREMENT SELECTION	3-6
RANGE SELECTION	3-7
HOLD MODE SELECTION	3-8
MIN / MAX HOLD USAGE	3-9
PEAK HOLD USAGE	3-9
ZERO FUNCTION	3-10
AUTOMATIC ZERO FUNCTION	3-11
MANUAL ZERO FUNCTION	3-12
RELATIVE MODE	3-13
AUTOMATIC RELATIVE MODE	3-14
MANUAL RELATIVE MODE	3-15
ANALOG OUTPUT FUNCTION	3-16
ANALOG OUTPUT USAGE	3-17
SOURCES OF MEASUREMENT ERRORS	3-19
MORE DETAILS ON AC MODE OPERATION	3-20
MORE DETAILS ON DC MODE OPERATION	3-21

Section - 4 Remote Operation

USB INTERFACE CONNECTION	4-1
REMOTE COMMAND STANDARDS	4-1
COMMAND FORMAT	4-1
ERROR BUFFER	4-2
STATUS REGISTERS	4-2
INFORMATION FOR REMOTE OPERATION	4-3
OTHER GENERAL 5180 FILE INFORMATION	4-4
STATUS BYTE AND REQUEST FOR SERVICE (RQS)	4-5
STANDARD EVENT REGISTER	4-7
MEASUREMENT EVENT REGISTER	4-8
OPERATION EVENT REGISTER	4-8
QUESTIONABLE EVENT REGISTER	4-8
“COMMON” COMMAND SYNTAX	4-9
“COMMON” COMMANDS	4-10
SCPI COMMAND SYNTAX	4-12
SCPI COMMANDS	4-13
ERROR MESSAGES AND COMMANDS	4-15
STATUS COMMANDS	4-16
MODE COMMANDS.....	4-17
RANGE COMMANDS	4-18
HOLD COMMANDS	4-19
ZERO COMMAND	4-20
RELATIVE COMMANDS	4-20
MEASUREMENT COMMAND	4-20
ANALOG OUTPUT COMMAND	4-21
OPERATION COMPLETE STATUS	4-22
MODEL 5100 ERROR CODES	4-23

WARRANTY

NOTICE:
See Pages 3-1 and 3-2 for
SAFETY instructions prior to first use !

List of Illustrations

Figure 1-1	Flux Lines of a Permanent Magnet.....	1-1
Figure 1-2	Hall Generator.....	1-2
Figure 1-3	Hall Probe Configurations.....	1-3
Figure 2-1	Standard Transverse Probe.....	2-3
Figure 2-2	Standard Axial Probe.....	2-4
Figure 2-3	Low Field Axial Probe.....	2-5
Figure 2-4	Zero Flux Chamber.....	2-6
Figure 3-1	Auxiliary Power Connector Warnings.....	3-1
Figure 3-2	Probe Electrical Warning.....	3-1
Figure 3-3	Operating Features.....	3-2
Figure 3-4	Battery Installation.....	3-3
Figure 3-5	Probe Connection.....	3-3
Figure 3-6	Power-Up Display.....	3-4
Figure 3-7	Missing Probe Indication.....	3-4
Figure 3-8	Low Battery Indication.....	3-6
Figure 3-9	Overrange Indication	3-6
Figure 3-10	MODE (AC-DC) Function.....	3-6
Figure 3-11	UNITS Function.....	3-6
Figure 3-12	RANGE Function.....	3-7
Figure 3-13	HOLD Function.....	3-8
Figure 3-14	Automatic ZERO Function.....	3-11
Figure 3-15	Manual ZERO Function.....	3-12
Figure 3-17	Automatic RELATIVE Function.....	3-14
Figure 3-18	Manual RELATIVE Function.....	3-15
Figure 3-19	OUTPUT Function.....	3-16
Figure 3-20	Analog Output Display.....	3-17
Figure 3-21	Adjusting the DC Offset of the Analog Output.....	3-18
Figure 3-22	Probe Output versus Flux Angle.....	3-19
Figure 3-23	Probe Output versus Distance.....	3-19
Figure 3-24	Flux Density Variations in a Magnet.....	3-20
Figure 4-3	Condition, Event and Enable registers.....	4-5
Figure 4-4	Status Byte and Enable registers.....	4-5
Figure 4-5	Standard Event register.....	4-7
Figure 4-6	Measurement Event register.....	4-8
Figure 4-7	Operation Event register.....	4-8
Figure 4-8	Questionable Event register.....	4-8

List of Tables

Table 4-1	Common Command Summary.....	4-10
Table 4-2	SCPI Command Summary.....	4-13

Statement regarding improvements to 5100 Series Gaussmeters

The 5100 Series Gauss / Tesla Meters now have improved AC performance and several operational improvements as a result of new DSP and microcontroller firmware.

Customers with meters manufactured prior to June 2007 and firmware versions below r2.00 and d2.00 should review this manual for changes in specifications. Certain operational sequences have been made more intuitive and require fewer keystrokes. Refer to the appropriate section of the Operator's Manual for details.

Summary of changes:

- Auto Relative now toggles On/Off with just 2 keystrokes.
- Settings for "HOLD" and "Probe Zero" are no longer retained when powered on/off. This often lead to the false appearance that the meter was malfunctioning in previous firmware versions.
- Analog Output now automatically applies optimum filtering to the signal, therefore the options of "LO" and "HI" have been removed and it is simply an On/Off selection.
- Peak Hold has been greatly improved with a shorter acquisition time.

USB Hub Compatibility

Like many USB devices on the market such as printers and digital cameras, operation of the 5180 with a USB hub may be problematic. It is recommended that customers wishing to make use of the remote operation capabilities of the 5180 make a direct connection to their computer USB port and not use a hub. Operation with a hub is not recommended.

Section 1 Introduction

UNDERSTANDING FLUX DENSITY

Magnetic fields surrounding permanent magnets or electrical conductors can be visualized as a collection of magnetic *flux* lines? Lines of force existing in the material that is being subjected to a magnetizing influence. Unlike light, which travels away from its source indefinitely, magnetic flux lines must eventually return to the source. Thus all magnetic sources are said to have two *poles*. Flux lines are said to emanate from the “north” pole and return to the “south” pole, as depicted in Figure 1-1.

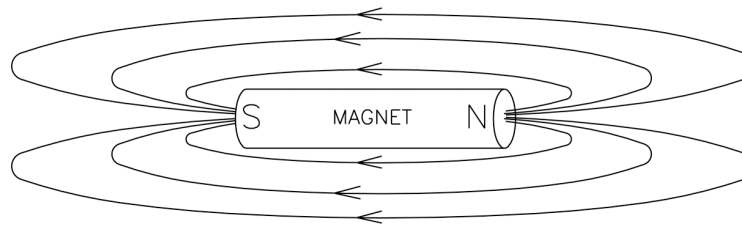

Figure 1-1
Flux Lines of a Permanent Magnet

One line of flux in the CGS measurement system is called a *maxwell* (M), but the *weber* (W), which is 108 lines, is more commonly used. Flux density, also called magnetic induction, is the number of flux lines passing through a given area. It is commonly assigned the symbol “*B*” in scientific documents. In the CGS system a *gauss* (G) is one line of flux passing through a 1 cm area. The more commonly used term is the *tesla* (T), which is 10,000 lines per cm . Thus

1 tesla = 10,000 gauss
1 gauss = 0.0001 tesla

Magnetic field strength is a measure of force produced by an electric current or a permanent magnet. It is the ability to induce a magnetic field “*B*”. It is commonly assigned the symbol “*H*” in scientific documents. The unit of “*H*” in the CGS system is an *oersted* (Oe), but the *ampere/meter* (Am) is more commonly used. The relationship is

1 oersted = 79.6 ampere/meter
1 ampere/meter = 0.01256 oersted

It is important to know that magnetic field strength and magnetic flux density are not the same. Magnetic field strength deals with the physical characteristics of magnetic materials whereas flux density does not. The only time the two are considered equal is in free space (air). Only in free space is the following relationship true:

1 G = 1 Oe = 0.0001 T = 79.6 Am

Section 1 Introduction

MEASUREMENT OF FLUX DENSITY

A device commonly used to measure flux density is the *Hall generator*. A Hall generator is a thin slice of a semiconductor material to which four leads are attached at the midpoint of each edge, as shown in Figure 1-2.

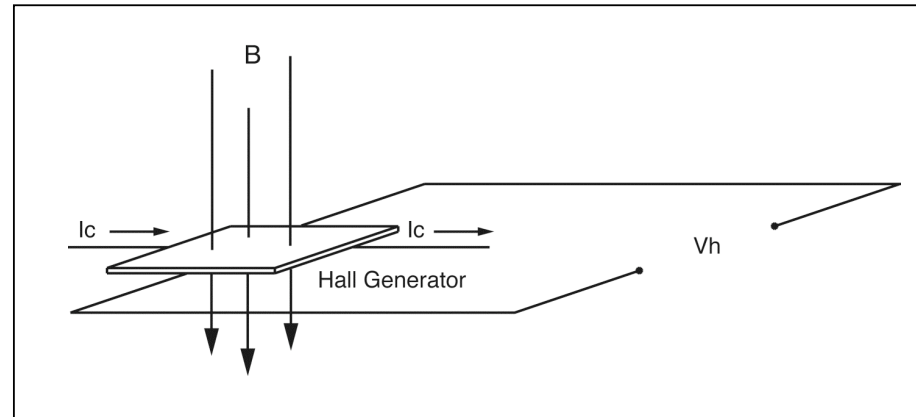

Figure 1-2
Hall Generator

A constant current (I_c) is forced through the material. In a zero magnetic field there is no voltage difference between the other two edges. When flux lines pass through the material the path of the current bends closer to one edge, creating a voltage difference known as the Hall voltage (V_h). In an ideal Hall generator there is a linear relationship between the number of flux lines passing through the material (flux density) and the Hall voltage.

The Hall voltage is also a function of the *direction* in which the flux lines pass through the material, producing a positive voltage in one direction and a negative voltage in the other. If the same number of flux lines pass through the material in either direction, the net result is zero volts. This sensitivity to flux direction makes it possible to measure both static (dc) and alternating (ac) magnetic fields.

The Hall voltage is also a function of the *angle* at which the flux lines pass through the material. The greatest Hall voltage occurs when the flux lines pass perpendicularly through the material. Otherwise the output is related to the cosine of the difference between 90° and the actual angle.

The sensitive area of the Hall generator is generally defined as the largest circular area within the actual slice of the material. This *active area* can range in size from 0.2 mm (0.008") to 19 mm (0.75") in diameter. Often the Hall generator assembly is too fragile to use by itself so it is often mounted in a protective tube and terminated with a flexible cable and a connector. This assembly, known as a Hall probe, is generally provided in two configurations:

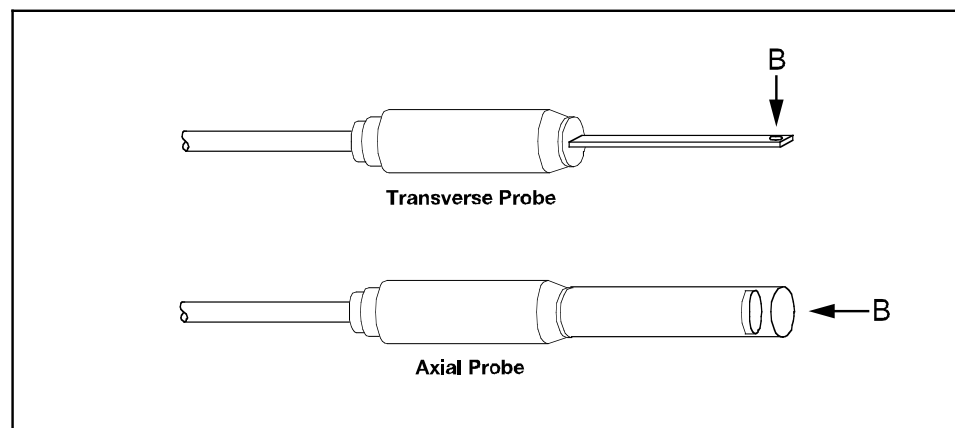

Figure 1-3
Hall Probe Configurations

In “transverse” probes the Hall generator is mounted in a thin, flat stem whereas in “axial” probes the Hall generator is mounted in a cylindrical stem. The axis of sensitivity is the primary difference, as shown by “B” in Figure 1-3. Generally transverse probes are used to make measurements between two magnetic poles such as those in audio speakers, electric motors and imaging machines. Axial probes are often used to measure the magnetic field along the axis of a coil, solenoid or traveling wave tube. Either probe can be used where there are few physical space limitations, such as in geomagnetic or electromagnetic interference surveys.



Handle the Hall probe with care. Do not bend the stem or apply pressure to the probe tip as damage may result. Use the protective cover when the probe is not in use.

PRODUCT DESCRIPTION

The *MODEL 5170 / 5180 GAUSS / TESLAMETER* is a portable instrument that utilizes a Hall probe to measure magnetic flux density in terms of gauss, tesla or ampere/meter. The measurement range is from 0.01 mT (0.1 G or 0.01 kA/m) to 3.000T (30.00 kG or 2388 kA/m) for the 5180, and 2.000T (20.00 kG or 1592 kA/m) for the 5170. The instrument is capable of measuring static (DC) and alternating (AC) magnetic fields.

The *MODEL 5170 / 5180* consists of a palmsized meter and various detachable Hall probes. The meter operates on 4 standard AA 1.5 volt alkaline batteries or can be operated with an external ACtoDC power supply. A retractable stand allows the meter to stand upright on a flat surface. The large display is visible at considerable distances. The instrument is easily configured using a keypad.

Three measurement ranges can be selected or the meter can automatically select the best range based on the present flux density being measured. A “zero” function allows the user to remove undesirable readings from nearby magnetic fields (including earth’s) or false readings caused by initial electrical offsets in the probe and meter. Included is a “zero flux chamber” which allows the probe to be shielded from external magnetic fields during this operation. Another feature called “relative mode” allows large flux readings to be suppressed so that small variations within the larger field can be observed directly. Both the “zero” and “relative” adjustments can be made manually or automatically.

Other features include three “hold” modes, allowing either the arithmetic maximum, minimum or instantaneous peak values to be held indefinitely until reset by the user. An analog signal is available from a standard BNC (5180 only) connector that is representative of the magnetic flux density signal and is calibrated to 3 volts full scale in dc mode or 3 Vrms in AC mode. This output can be connected to a voltmeter, oscilloscope, recorder or external analog to digital converter.

The meter can be fully configured and flux density readings acquired from a remote computer or PLC using the USB communications port. (5180)

The meter, probes and accessories are protected when not in use by a sturdy carrying case.

APPLICATIONS

- Sorting or performing incoming inspection on permanent magnets, particularly multipole magnets.
- Testing audio speaker magnet assemblies, electric motor armatures and stators, transformer lamination stacks, cut toroidal cores, coils, and solenoids.
- Determining the location of stray fields around medical diagnostic equipment.
- Determining sources of electromagnetic interference.
- Locating flaws in welded joints.
- Inspection of ferrous materials.
- Field mapping.
- Inspection of magnetic recording heads.

Section 2 Specifications

		5170	5180
Ranges:	Ultra Low Probe	1 G	1 G
	Low	200 G	300 G
	Mid	2 kG	3 kG
	High	20 kG	30 kG
Resolution:	Ultra Low Probe	1 mG	1 mG
	Low	0.1 G	0.1 G
	Mid	1.0 G	1.0 G
	High	10 G	10 G

Specifications continued on next page

SPECIFICATIONS, MODEL 5170 & 5180 GAUSS / TESLAMETER without probe, 23 ±3°C, RH <85%

	5170	5180
DC MODE, Low Range:	1.25 + 4	0.8 + 4
Mid & High Ranges:	1.00 + 3	0.6 + 3
AC MODE (for sinewave >6G or 0.6mT) {1}		
10 - 20 Hz	3.50 + 8	3.0 + 8
20 - 20,000 Hz :	2.50 + 5	2.0 + 5
20kHz to 25kHz (1x axial probe only)	N/A	3.0 + 5

{1} additional ±8 counts tolerance for signals
< 4% of lowest range and >2kHz

ACCURACY, Analog Output of Model 5180 (±% of Reading ± mV)

DC MODE	Low Range:	0.75 + 6
	Mid & High Ranges:	0.50 + 5
AC MODE :	(for sinewave >6G or 0.6mT) {2}	
	10 - 20Hz	3.00 + 8
	20 - 5000Hz	2.50 + 5
Analog output -3dB point is approximately 22kHz		
Delay Time: 30µs		
Sample Rate: 8µs with variable moving average filtering		
Risetime: DC Mode = 250µs DC peak hold = 60µs		
AC Mode and AC Peak Hold; from 30µs to 2ms depending on freq.		

{2} additional ±8 mV tolerance for signals
< 4% of lowest range and >2kHz

Battery Type: 1.5V AA (x4)

Battery Life: 20 hours typical, alkaline batteries

Auxilliary Power: +5 Vdc, 300 mA (Regulated)

Auxilliary Power Connector: Standard 2.5mm I.D. / 5.5mm O.D. connector. Center post is (+) polarity.

Analog Output Connector: BNC

Operating Temperature: 0 to +50°C (+32 to +122°F)

Storage Temperature: -25 to +70°C (-13 to +158°F)

Meter Dimensions: Length: 17.5 cm (6.9 in)
Width: 9.9 cm (3.9 in)
Height: 3.6 cm (1.4 in)

Weight: Meter w/batteries: 400 g (14 oz.)
Shipping: 1.59 kg (3 lb., 8 oz.)

Probe accuracy must be added to meter accuracy to determine overall accuracy

Warmup Time To Rated Accuracy:	5 minutes
Min / Max Hold Acquisition Time:	DC mode: 100 ms typical AC mode: 700 ms at 10 Hz to 500 ms at 300 Hz 250 ms at 300 - 4000 Hz 100 ms > 4kHz
Peak Hold Acquisition Time:	DC or AC mode: 128 µs minimum
Analog Output Scaling:	DC mode: ± 3 Vdc AC mode: 3 Vrms
Analog Output Noise:	(Hi- Range) 1.5mV rms (Mid- Range) 4.5mV rms (Low- Range) 15.5mV rms
Analog Output Load:	10 kOhm min, 100 pF max.
Accuracy Change with Temperature (not including probe) 0-20°C and 26-50°C (typical) Low Range: ±0.25% + 3.0 counts / °C Mid & High Ranges: ±0.02% + 0.2 counts / °C	

Regulatory Information:

Compliance was demonstrated to the following specifications as listed in the official Journal of the European Communities:

EN 61326-1:1997+A1:1998 Electrical equipment for measurement, control and laboratory use EMC requirements

Immunity:

IEC 61000-4-2 Electrostatic Discharge (ESD)
IEC 61000-4-3 Electromagnetic Field (RF)

Emissions:

EN 55022 Class B Radiated and conducted emissions

Communications Port:

Format: Universal Serial Bus (USB)
Lines supported: Transmit, receive, common.
Connector type: Mini USB Type B
Cable length: 3 m (9.8 ft.) maximum
Standards supported: IEEE-1987.2, SCPI-1991

STANDARD TRANSVERSE PROBE

Model Number: (5180): STD18-0404
(5170): STH17-0404

Frequency Bandwidth: (5180): 0 to 20 kHz
(5170): 0 to 10 kHz

Offset change with Temperature: ±300 mG / °C (typical)
Accuracy change with Temperature: -0.05%/°C (typical)
Operating Temperature Range: 0 to +75°C (+32 to +167F)
Storage Temperature Range: -25 to +75°C (-13 to +167F)

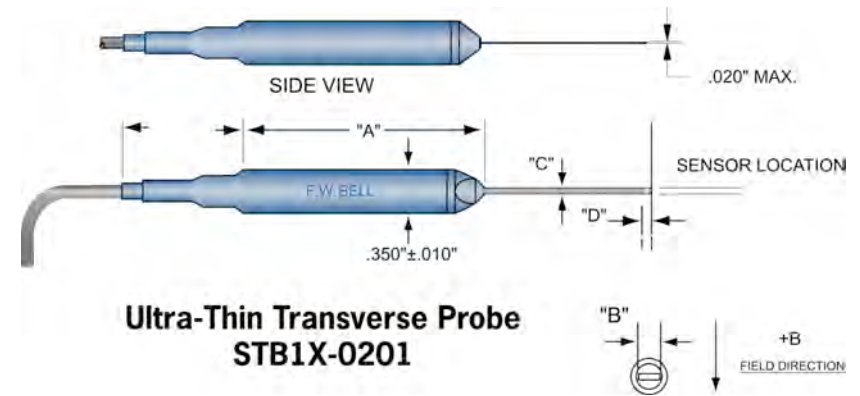

Model	A ± 0.063"	B	C	D	Material	Corrected Linearity	Sensitivity	Active Area	Operating Temp. Range	Temp. stability (typ)		Frequency Response				
										Zero	Calibrate					
STD18-0402	2"	0.158" ±.004	0.045" ±.004	0.0335" (NOM)	Polypropylene **see note	0.5%/30kG	1X	0.015" DIA (NOM)	0°C to +75°	±0.030 Gauss/°C (typical)	-0.05 %/°C (typical)	DC to 20kHz				
STD18-0404	4"					1.0%/20kG							DC to 10kHz			
STH17-0402	2"					ALUMINUM 3003 ¾ FH								1.0%/20kG	DC to 10kHz	
STH17-0402	4"				0.5%/30kG							DC to 20kHz				
HTH17-0604	4"	0.180" ±.004	0.060" +.000 -.004		0.030" (NOM)	KAPTON							1.0%/10kG	0.025" DIA (NOM)	±0.200 Gauss /°C	-0.1% /°C
HTD18-0604	4"											0.5%/30kG	DC to 20kHz			
STB1X-0201	1"	.050" ±.005	.020" MAX	1.0%/10kG												

Note: Due to continuous process improvement, specifications are subject to change without notice.

** Prior to late 2006 Transverse Probe Stems were rigid glass epoxy, .150 x .040".

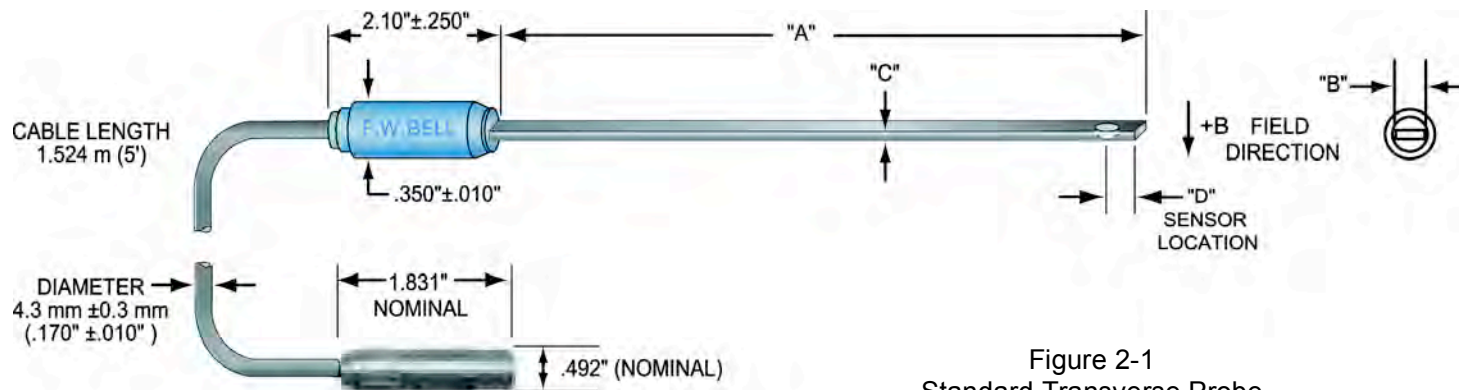

Figure 2-1
Standard Transverse Probe

STANDARD AXIAL PROBE

Model Number: (5180): SAD18-1904
(5170): SAH17-1904

Flux Density Range: (5180): 0 to ± 30 kG (0 to 3 T)
(5170): 0 to ± 20 kG (0 to 2 T)

Corrected Linearity: (5180): $\pm 0.5\%$ to ± 30 kG
(5170): $\pm 1.0\%$ to ± 20 kG

Frequency Bandwidth: (5180): 0 to 25 kHz
(5170): 0 to 10 kHz

5180 gaussmeter probes
SAD18-1904 4" Axial Probe
SAD18-1902 2" Axial Probe

5170 gaussmeter probes
SAH17-1904 4" Axial Probe
SAH17-1902 2" Axial Probe

Offset change with Temperature: ± 300 mG / $^{\circ}\text{C}$ (typical)

Accuracy change with Temperature: -0.05% / $^{\circ}\text{C}$ (typical)

Operating Temperature Range: 0 to $+75^{\circ}\text{C}$ ($+32$ to $+167^{\circ}\text{F}$)

Storage Temperature Range: -25 to $+75^{\circ}\text{C}$ (-13 to $+167^{\circ}\text{F}$)

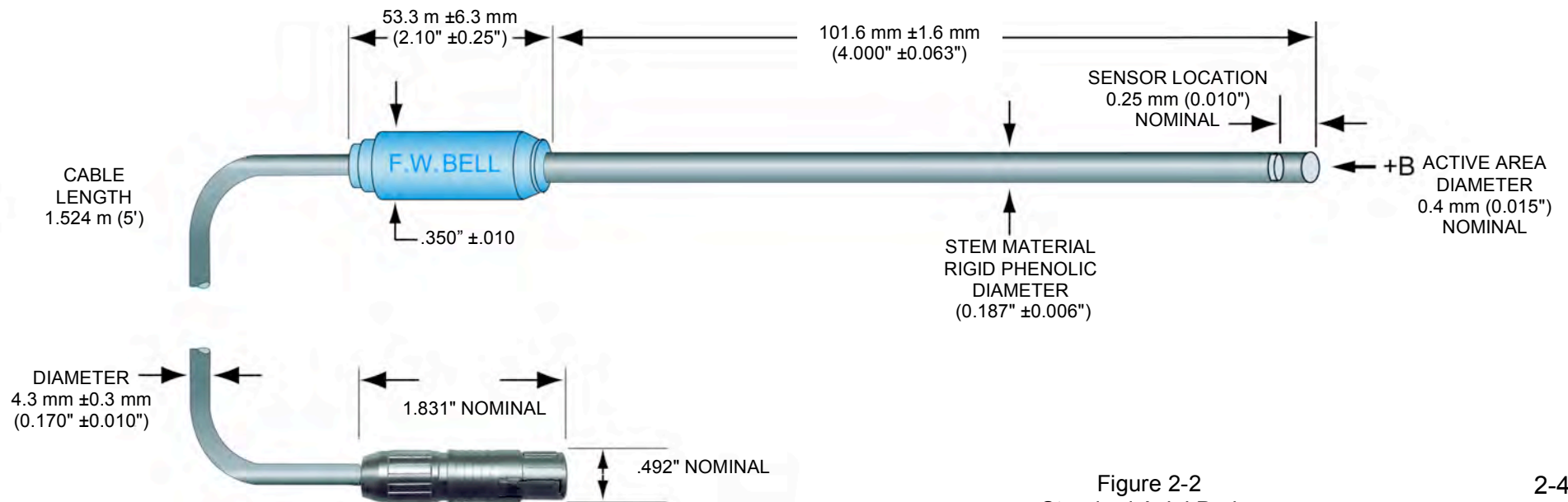

Figure 2-2
Standard Axial Probe

LOW FIELD AXIAL PROBE

Model Number: MOS51-3204

Flux Density Range: $\pm 1\text{G}$ ($100\mu\text{T}$) DC or peak AC

Corrected Linearity: $\pm 0.75\%$ of Reading

Frequency Bandwidth: 0 to 700 Hz (-3dB)

Offset change with Temperature: $\pm 0.02\text{mG} / ^\circ\text{C}$ (typical)

Accuracy change with Temperature: 0.001 % / $^\circ\text{C}$ (typical)

Operating Temperature Range: 0 to $+75^\circ\text{C}$ ($+32$ to $+167\text{F}$)

Storage Temperature Range: -25 to $+75^\circ\text{C}$ (-13 to $+167\text{F}$)

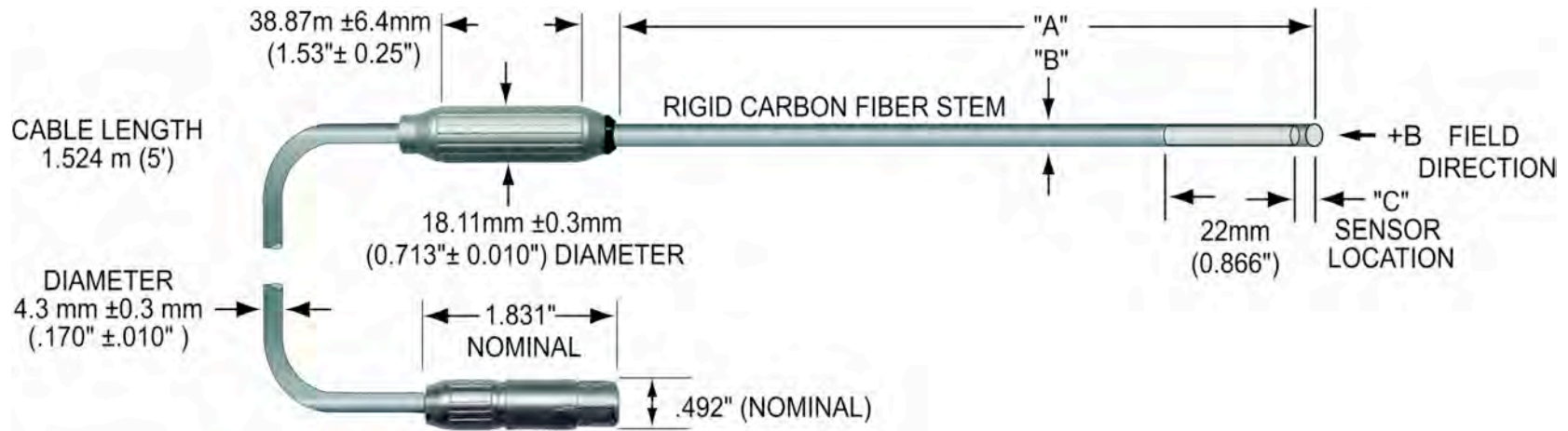

Figure 2-3
Low Field Axial Probe

ZERO FLUX CHAMBER

MODEL NUMBER: YA111

CAVITY DIMENSIONS:

Length: 50.8 mm (2")
Diameter: 8.7 mm (0.343")

ATTENUATION: 80 dB to 30 mT (300 G)

PURPOSE: To shield the probe from external magnetic fields during the ZERO or RELATIVE operations.

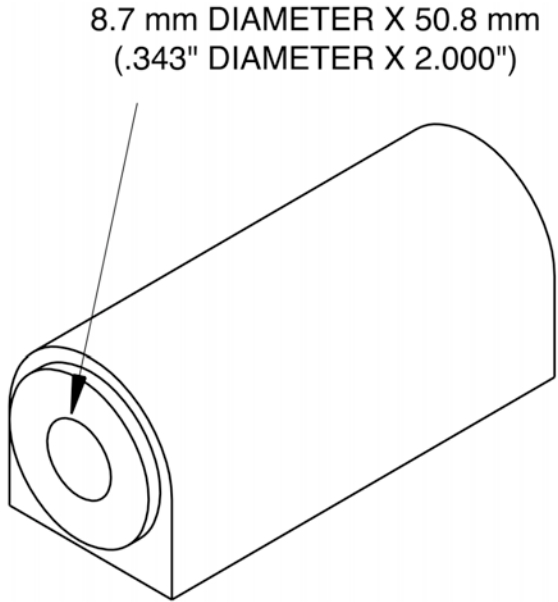

Figure 2-4

Zero Flux Chamber

Section 3 Operating Instructions

OPERATOR SAFETY



Do not connect the auxiliary power connector to an AC power source. Do not exceed 5 Vdc regulated. Do not reverse polarity. Use only a regulated AC to DC power supply certified for country of use.

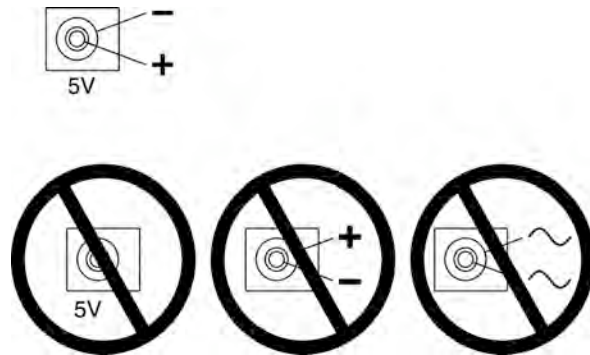

Figure 3-1
Auxiliary Power Connector Warnings



This symbol appears on the instrument and probe. It refers the operator to additional information contained in this instruction manual, also identified by the same symbol.



Do not allow the probe to come in contact with any voltage source greater than 30 Vrms or 60 Vdc

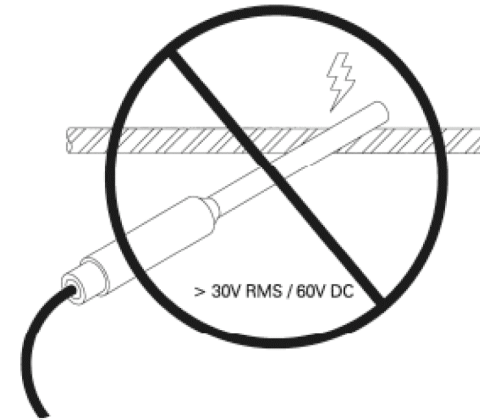

Figure 3-2
Probe Electrical Warning



Batteries contain ferrous materials that are attracted to magnetic fields. Be careful when operating the instrument near large magnetic fields, as it may move without warning

OPERATING FEATURES

Display. Liquid crystal display (LCD).

Auto Zero. To select AUTO ZERO operation, press the ZERO pushbutton. Unit automatically returns to normal operation.

Manual Zero. To select MANUAL ZERO operation, press the SHIFT pushbutton followed by the ZERO pushbutton. Use the LEFT (3) and RIGHT (4) arrow pushbuttons to select digit. Use the UP (5) and DOWN (6) arrow pushbuttons to make fine adjustments as needed. Press the RESET pushbutton to clear the offset value. Press the SHIFT pushbutton followed by the ZERO pushbutton to return to normal operation.

Auto Relative.* To select AUTO RELATIVE operation, press the RELATIVE pushbutton. Unit automatically returns to normal operation. AUTO RELATIVE automatically turns the relative offset ON. Push again to turn OFF.

Manual Relative.* To select MANUAL RELATIVE operation, press the SHIFT pushbutton followed by the RELATIVE pushbutton. Press the LEFT (3) arrow pushbutton to turn offset ON. Press the RIGHT (4) arrow pushbutton to turn offset OFF. Use the LEFT (3) and RIGHT (4) arrow pushbuttons to select digit. Use the UP (5) and DOWN (6) arrow pushbuttons to make fine adjustments as needed. Press the RESET pushbutton to clear the offset value. Press the SHIFT pushbutton followed by the RELATIVE pushbutton to return to normal operation.

Auto Range. To select AUTO RANGE operation, press the SHIFT pushbutton followed by the RANGE pushbutton. Press the SHIFT pushbutton followed by the RANGE pushbutton to exit Auto Range mode.

Manual Range. To select MANUAL RANGE operation, press the RANGE pushbutton. Press the UP (5) and DOWN (6) arrow pushbuttons to select ranges. Press the RANGE pushbutton to return to normal operation.

Units. To select UNITS, press the SHIFT pushbutton followed by the LEFT (3) arrow pushbutton. Press the UP (5) and DOWN (6) arrow pushbuttons to select flux density readings in gauss, tesla or amperimeters. Press the SHIFT pushbutton followed by the LEFT (3) pushbutton to return to normal operation.

Hold. To select the HOLD operation, press the SHIFT pushbutton followed by the RESET pushbutton. Press the LEFT (3) and RIGHT (4) arrow pushbuttons to select between MIN HOLD, MAX HOLD, PEAK HOLD*, and HOLD

OFF. In any mode press the RESET pushbutton to clear the held reading. Press the SHIFT pushbutton followed by the RESET pushbutton to return to normal operation.

AC/DC. To select either AC or DC mode, press the SHIFT pushbutton followed RIGHT (4) arrow pushbutton.

Analog Output.*To enable and disable ANALOG OUTPUT operation, press the SHIFT pushbutton followed by the UP (5) arrow pushbutton.

ON/OFF. Press the ON/OFF pushbutton to power the unit ON. To turn the unit OFF, press the ON/OFF pushbutton for 3 seconds.

SLEEP MODE. This feature turns unit the OFF after one hour of inactivity (i.e. user input, remote commands etc.)

Press the SHIFT pushbutton followed by the ON/OFF pushbutton to enable and disable this feature. The battery symbol and either ON or OFF will flash to indicate the state that has been selected.

FIRMWARE VERSION. The firmware versions for the microcontroller and DSP may be displayed by pressing RESET for more than 1 second while in any normal operating mode. For example: r2.00 d2.00.

*5180 Model only

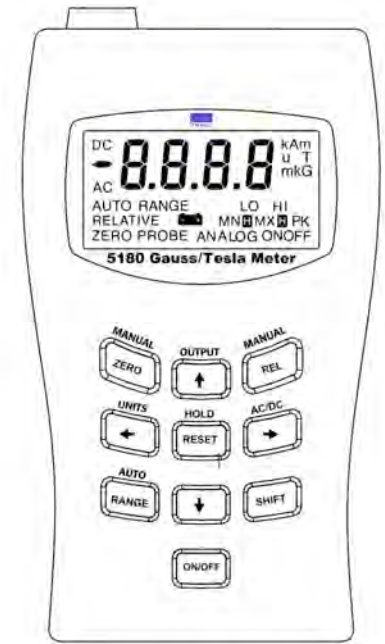

Figure 3-3
Operating Features

INSTRUMENT PREPARATION

- 1) With the power switch turned off apply pressure to the battery compartment cover at the point shown in Figure 3-4. Slide the cover open and remove.
- 2) Install four AA 1.5V alkaline batteries. The battery compartment is designed to indicate the battery polarity. Reinstall the battery compartment cover.
- 3) If using an AC to DC power supply, review Figure 3-1 for safety notes and the *SPECIFICATIONS* section for voltage and current ratings.
- 4) Install the probe by matching the keyway in the connector to that in the mating socket in the meter. The connector will lock in place when fully installed. To disconnect, pull on the body of the connector, *not the cable!*

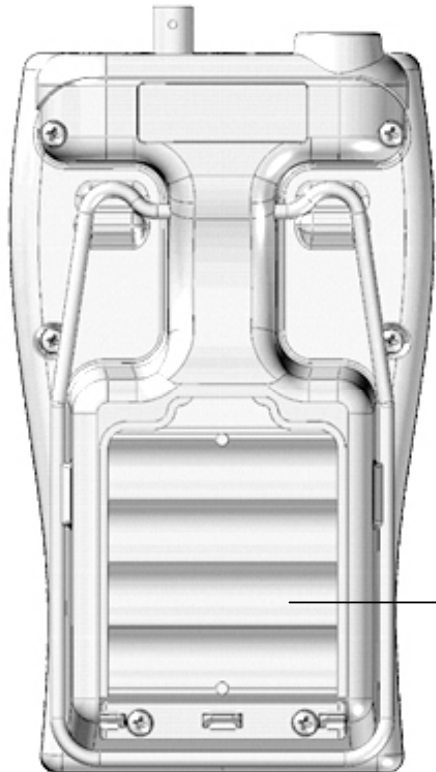

Figure 3-4
Battery Installaltion

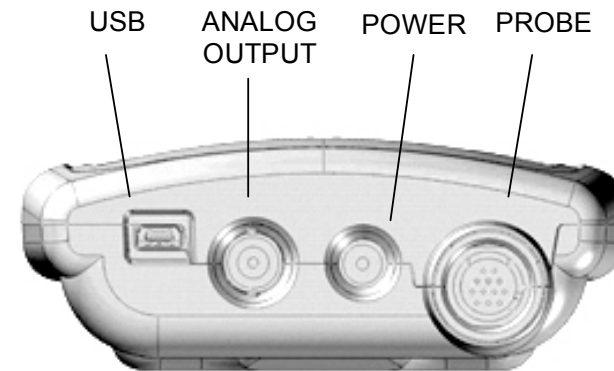

Figure 3-5
Probe Connection

POWER-UP

Press the POWER switch. There will be a momentary audible beep and all display segments will appear on the display.

The instrument will conduct a self test before measurements begin. If a problem is detected the phrase "Err" will appear on the display followed by a 3 digit code. The circuitry that failed will be retested and the error code will appear after each failure. This process will continue indefinitely or until the circuitry passes the test. A condition in which a circuit fails and then passes should not be ignored because it indicates an intermittent problem that should be corrected.

If the self test is successful the meter will perform a self calibration. During this phase the meter will display a calibration sequence "CALX" message. Calibration will halt if there is no probe connected. Until the probe is connected the phrase "Err" will appear accompanied by a flashing "PROBE" annunciator as shown in Figure 3-7.

Per the *SPECIFICATIONS* section, allow 15 minutes warmup time for rated accuracy.

The most common errors displayed are a result of damage to the sensing element located in the tip of the probe. A damaged sensing element can result in the following error codes: E064 and E067.

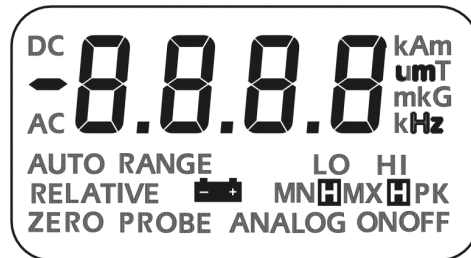

Figure 3-6
Missing Probe Indication

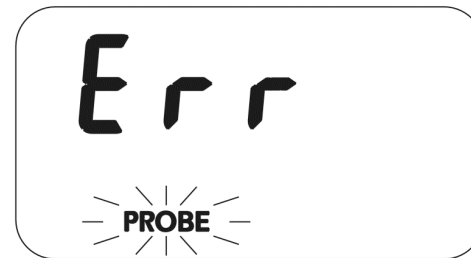

Figure 3-7
PowerUp Display

POWER-UP SETTINGS

The meter permanently saves certain aspects of the instrument's setup and restores them the next time the meter is turned on. The conditions that are saved are:

RANGE setting (including AUTO range)
MODE (AC or DC)
UNITS of measure (gauss, tesla or amperemeter)
OUTPUT function

Other aspects are not saved and default to these conditions:

RELATIVE mode (turned OFF)
RELATIVE value (set to 0)
ZERO mode (inactive)
HOLD mode (turned OFF)

LOW BATTERY CONDITION

The meter is designed to use four standard AA 1.5V alkaline batteries . When the battery voltage becomes too low the battery symbol on the display will flash, as shown in Figure 3-8. Replace the batteries or use an external AC to DC power supply.



Instrument specifications are not guaranteed when a low battery condition exists!

OVERRANGE CONDITION

If the magnitude of the magnetic flux density exceeds the limit of the selected range the meter will display a flashing value of “2999” (gauss or tesla mode) or “2387” (ampere meter mode). The next highest range should be selected. If already on the highest range then the flux density is too great to be measured with this instrument.

AC OR DC MEASUREMENT SELECTION

The meter is capable of measuring either static (DC) or alternating (AC) magnetic fields. To choose the desired mode Press the SHIFT pushbutton followed by the right (4) arrow to select AC or DC on the display. The DC and AC mode is discussed in more detail later in this section. This setting is saved and will be restored the next time the meter is turned on.

UNITS OF MEASUREMENT SELECTION

The meter is capable of providing flux density measurements in terms of gauss (G), tesla (T) or ampere/meters (A/m). To choose the desired units, Press the SHIFT pushbutton followed by the left (3) arrow pushbutton. Press the up (5) and down (6) arrow pushbuttons to select G, T or Am on the display. This setting is saved and will be restored the next time the meter is turned on.

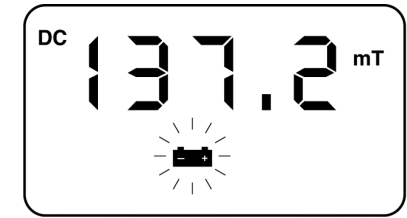

Figure 3-8
Low Battery Indication

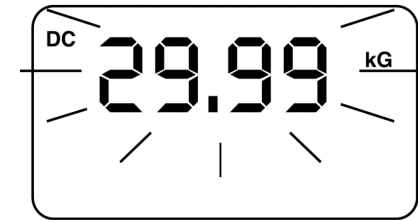

Figure 3-9
Overrange Indication

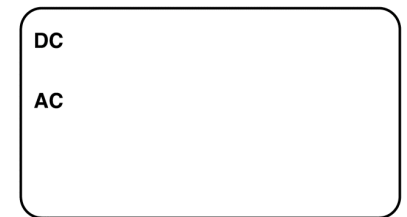

Figure 3-10
MODE (AC/DC) Function

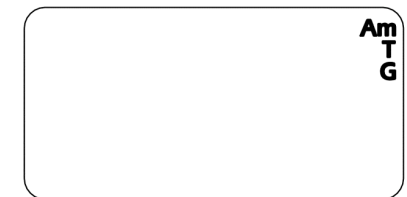

Figure 3-11
UNITS Function

RANGE SELECTION

The meter is capable of providing flux density measurements on one of three fixed ranges, or it can be programmed to automatically select the best range for the present flux density. The available ranges are listed in the *SPECIFICATIONS* section of this manual. The ranges advance in decade steps. The lowest range offers the best resolution while the highest range allows higher flux levels to be measured.

In the autorange mode, the range is advanced if the reading reaches 95% of the present range. The range is lowered when the reading falls below 9% of full scale for the present range. The speed at which the readings are updated decreases slightly when AUTO ranging is used.

NOTE: The AUTO range selection will be canceled if the RELATIVE mode is turned on.

To choose the desired range, press the RANGE pushbutton. The "RANGE" legend will flash. Press the UP (5) and DOWN (6) pushbuttons to select the desired range. To choose AUTO RANGE on the display, press the SHIFT pushbutton followed by the RANGE pushbutton.

This setting is saved and will be restored the next time the meter is turned on.

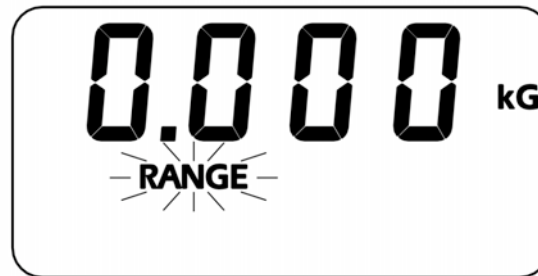

Figure 3-12
RANGE Function

HOLD MODE SELECTION

In some applications it may be desirable to hold a reading that is either greater than or less than all previous readings, or which has the greatest peak value whether positive or negative.

The MAX HOLD function holds the reading that is arithmetically greater than all previous readings. For instance a reading of +125.0 is greater than +99.0 or -150.0.

The MIN HOLD function holds the reading that is arithmetically less than all previous readings. For instance a reading of -125.0 is less than 99.0 or +150.0.

The PEAK HOLD function captures and holds the peak value of the flux density waveform within the response time capabilities of the meter. See the *SPECIFICATIONS* section of this manual for more information. The peak can be either positive or negative, whichever has the greatest magnitude. For instance a peak value of -100.0 is greater than a peak value of +90.0.

To choose the desired hold mode press the SHIFT pushbutton followed by the RESET pushbutton. Press the LEFT (3) and RIGHT (4) arrows to select the desired mode on the display. MAX HOLD is indicated by "MX". MIN HOLD is indicated by "MN". PEAK HOLD is indicated by "PK". The "OFF" legend will appear when all HOLD modes are turned off.

Difference between PEAK and MAX for AC: Max is the maximum rms value. PEAK gives the value of the point on the waveform with the greatest amplitude.



Figure 3-13
HOLD Function

MIN / MAX HOLD USAGE

See the *SPECIFICATIONS* section for response time information.

The MAX HOLD function holds the reading that is arithmetically greater than all previous readings. The MIN HOLD function holds the reading that is arithmetically less than all previous readings. These modes are useful in determining the maximum or minimum value of magnetic events that occur over a period of time.

If the reading exceeds the range limit the 5180 meter will hold a flashing value of "2999" (gauss or tesla mode), "2387" (ampere meter mode) or the maximum value allowed in the RELATIVE mode. The 5170 meter will hold a flashing value of "1999" (gauss or tesla mode), "1592" (ampere meter mode) or the maximum value allowed in the RELATIVE mode.

The held value can be reset by pressing the RESET pushbutton. The next value displayed after a reset will be the present value of flux density. For instance if the held reading is 200.0 G and the present flux density is 100.0 G, the meter will display 100.0 G after the reset.

If the analog output is being used the output signal will continue to represent the real time flux density as seen by the probe. It is not affected by the HOLD function.

PEAK HOLD USAGE

See the *SPECIFICATIONS* section for response time and accuracy information.

In the PEAK HOLD mode the input signal is sampled many times each second. Each sample is compared to all previous samples and that which has the greatest amplitude (regardless of polarity) is held on the display. This mode can be used to capture the peak value of a fast, onetime magnetic event such as a magnetizing pulse.

These are the differences between the PEAK HOLD mode and the MIN / MAX HOLD modes:

The PEAK HOLD mode considers the magnitude of the reading regardless of the polarity.

The response time of the PEAK HOLD mode is much faster but final accuracy is less.

If the analog output is being used the output signal will continue to represent the real time flux density as seen by the probe. It is not affected by the HOLD function.

ZERO FUNCTION

“Zeroing” the probe and meter is one of the most important steps to obtaining accurate dc flux density measurements. The ideal Hall generator produces zero output in the absence of a magnetic field, but actual devices are subject to variations in materials, construction and temperature. Therefore most Hall generators produce some output even in a zero field. This will be interpreted by the meter as a flux density signal.

Also, the circuits within the meter can produce a signal even when there is no signal present at the input. This will be interpreted as a flux density signal. Lastly magnetic sources close to the actual field being measured, such as those from electric motors, permanent magnets and the earth (roughly 0.5 gauss or 50mT), can induce errors in the final reading.

It is vital to remove these sources of error prior to making actual measurements. The process of “zeroing” removes all of these errors in one operation. The meter cancels the combined DC error signal by introducing another signal of equal magnitude with opposite polarity. After zeroing, the only dc signal that remains is that produced by the probe when exposed to magnetic flux.

NOTE: Zeroing the meter and probe affects only the static (DC) component of the flux density signal.

NOTE: The process of zeroing also affects the analog signal.

There may be situations when the user prefers to shield the probe from all external magnetic fields prior to zeroing. Provided with the meter is a ZERO FLUX CHAMBER which is capable of shielding against fields as high as 30 mT (300 G or 23.88 kA/m). The probe is simply inserted into the chamber before the zeroing process begins.



Handle the Hall probe with care. Do not bend the stem or apply pressure to the probe tip as damage may result. Use the protective cover when the probe is not in use.

In other situations the user may want the probe to be exposed to a specific magnetic field during the zeroing process so that all future readings do not include that reading (such as the earth’s field). This is possible with the following restrictions:

- 1) The external field must not exceed 30 mT (300 G or 23.88 kA/m).
- 2) The field must be stable during the zeroing process. It should not contain alternating (AC) components.

AUTOMATIC ZERO FUNCTION

The meter provides two methods to zero the probe. The first is completely automatic. Prepare the probe for zeroing, then press the ZERO pushbutton. The “ZERO” icon will flash and actual dc flux density readings will appear on the display. If the reading before zeroing the probe exceeds ± 30 mT (300 G or 23.88 kA/m) when the probe is in a zero chamber or very low field, then the probe may be defective. The meter will switch over to the DC mode of operation during zeroing. Recall that the zeroing operation affects DC offsets only. If you wish to suppress an AC field reading consider using the RELATIVE mode.

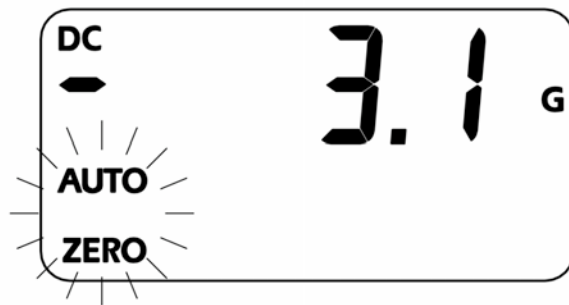

Figure 3-14
Automatic ZERO Function

Once automatic zeroing begins it must be allowed to complete. During this time all controls are disabled except for the POWER switch. The process normally takes from 5 to 15 seconds.

The meter selects the lowest range and adjusts the nulling signal until the net result reaches zero. At this point the automatic process is terminated and the flashing “AUTO” and the “ZERO” icons will disappear.

If the nulling process is successful, the next highest range is selected. No further electronic adjustments are made, but at this stage a reading is acquired which will be mathematically subtracted from all future readings on this range. This process is then repeated for the highest range. When finished, the meter will sound an audible beep and the flashing “AUTO” and “ZERO” icons will disappear. At this point the automatic process can be repeated or a manual adjustment can be performed (see “Manual Zeroing”).

The final zero values will remain in effect until the meter and probe are zeroed again.

NOTE: Zeroing the probe cancels the RELATIVE mode if it was turned on.

MANUAL ZERO FUNCTION

The second zeroing method is a manual adjustment. This feature also allows the user to set the “zero” point to something other than zero, if desired. Position the probe for zeroing, then press the "SHIFT" pushbutton followed by the "ZERO" pushbutton. The “ZERO” icon will flash and actual DC flux density readings will appear on the display. The meter will select the lowest range regardless of which range was in use prior to selecting the ZERO function. If the reading before zeroing the probe exceeds $\pm 30\text{mT}$ (300 G or 23.88 kA/m) when the probe is in a zero chamber or very low field, then the probe may be defective. The meter will switch over to the DC mode of operation during zeroing. Recall that the zeroing operation affects DC offsets only. If you wish to suppress an AC field reading consider using the RELATIVE mode.

By pressing the UP (5) or DOWN (6) arrows the reading will be altered. Pressing the UP (5) arrow adds to the reading, pressing the DOWN (6) arrow subtracts from the reading.



Figure 3-15
MANUAL ZERO Function

NOTE: Making a manual ZERO adjustment not only affects the lowest range, but also the higher ranges to a lesser extent. For example, assume an automatic ZERO has already been performed, after which all three ranges should read zero. Now a manual adjustment is made that causes the reading on the lowest range to be nonzero. The reading on the other ranges may also be nonzero depending upon the magnitude of the change. The adjustment has 10 times less effect on the middle range and 100 times less effect on the highest range.

NOTE: Zeroing the probe cancels the RELATIVE mode if it was turned on.

RELATIVE MODE

The RELATIVE mode allows a specific flux density value to be subtracted from all incoming readings. When the RELATIVE mode is active, all incoming readings are "relative" to an offset selected by the user. For example, if the displayed value is +100 gauss when RELATIVE mode is activated, and the flux density at the probe changes to +150 gauss the displayed value will be +50.0 gauss. If the flux density then drops to +50 gauss, the value displayed by the meter will be -50 gauss. The RELATIVE mode allows for the direct readout of variations around a given field level, whether static (DC) or alternating (AC).

There are two ways to generate a relative value. When AUTO RELATIVE is selected, the meter uses the present flux density reading as the relative value. When MANUAL RELATIVE is selected, the user can specify a desired relative value using the up, down, left, and right keypad arrows. Each mode will be discussed in more detail.

There are two restrictions when using the RELATIVE mode.

1) The RELATIVE mode can only be used in a fixed range. If the AUTO RANGE feature is in use and the RELATIVE mode is turned on, the AUTO RANGE feature is disabled. Conversely, if the RELATIVE mode is turned on and the AUTO RANGE feature is activated, the RELATIVE mode is disabled.

2) If the meter is in the RELATIVE mode and a ZERO function is selected, (either MANUAL ZERO or AUTO ZERO), the RELATIVE mode is disabled.

There may be situations when the user may prefer to shield the probe from all external magnetic fields prior to performing a RELATIVE operation. Provided with the meter is a ZERO FLUX CHAMBER which is capable of shielding against fields as high as 30mT (300G or 23.88kA/m). The probe is simply inserted into the chamber before the RELATIVE operation begins.

NOTE: The RELATIVE mode is disabled when the probe and meter are zeroed or if the meter's power is cycled.

NOTE: If the analog output is being used, the output signal will continue to represent the flux density as seen by the probe. The analog output is not affected by the RELATIVE operation.



Handle the Hall probe with care. Do not bend the stem or apply pressure to the probe tip as damage may result. Use the protective cover when the probe is not in use.

AUTOMATIC RELATIVE MODE

In the automatic relative mode, the present flux density as seen by the probe is used as the relative offset value. Prepare the probe and select an appropriate range and mode (AC or DC) as needed (AUTO RANGE is deactivated when RELATIVE MODE is used). To automatically assign the current reading as the relative offset value, press the REL key.

The AUTO and RELATIVE icons will flash momentarily indicating the operation. When complete, the unit will return to the measurement mode and the RELATIVE icon will be on indicating that a relative value is being subtracted from all subsequent readings.

To deactivate the relative mode, press the SHIFT key followed by the REL key.

Difference between ZERO and RELATIVE: ZERO introduces an electrical offset signal into the circuitry. RELATIVE is strictly a mathematical process.



Figure 3-17
AUTOMATIC RELATIVE Function

MANUAL RELATIVE MODE

The second method by which to set a relative value is a manual adjustment. In some cases the user will wish to set an absolute relative value. To do this, insert the probe in the "zero flux chamber" provided with this meter.

To manually assign a relative offset value, press the SHIFT key followed by the REL key. At this point the "RELATIVE" icon will be flashing and actual flux density readings will be displayed. Use the LEFT, RIGHT, UP, and DOWN arrow keys to select a desired offset. When complete press the SHIFT key followed by the REL key to exit and return to the measurement mode. The RELATIVE icon will be on indicating that a relative offset is being subtracted from all incoming readings.

In other cases, the probe may be positioned in a stable DC or AC magnetic field that does not exceed the present range limit. In most cases the reading will be adjusted to zero so that the value of the reference is subtracted from all incoming readings.

To deactivate the manual relative mode, press the SHIFT key followed by the REL key. The meter will enter the MANUAL RELATIVE mode. Press the LEFT arrow key until the OFF icon turns on, then press the SHIFT key followed by the REL key to exit and return to the measurement mode. Alternatively, from within the MANUAL RELATIVE mode, Press the RESET key to clear the relative offset value. Press the SHIFT key followed by the REL key to exit and return to the measurement mode.



Handle the Hall probe with care. Do not bend the stem or apply pressure to the probe tip as damage may result.



Figure 3-18
MANUAL RELATIVE Function

ANALOG OUTPUT FUNCTION

The 5180 meter is capable of providing an analog voltage signal proportional to the present flux density level. Calibration is set to 3.0V full scale DC or 3.0VRMS AC, depending upon the mode of operation. This signal, available at the BNC connector, can be connected to a voltmeter, oscilloscope, recorder, data logger, or external analog to digital converter.

Power consumption increases when using the analog output. If use of the analog output port is unnecessary, maximize battery life by disabling the analog output feature. To toggle the analog output on or off, simply press the SHIFT key followed by the UP arrow key. The ANALOG ON icon will turn on when the analog output feature is active.



Figure 3-19
Output Function

ANALOG OUTPUT USAGE

See the SPECIFICATIONS section for frequency range and accuracy of the analog output.

The analog output signal is calibrated to 3VDC or 3VRMS depending on the selected mode. The analog output voltage is proportional to the flux density being measured depending on the meters current range. For instance, when in the 30mT DC range a reading of 12.3mT relates to an analog output voltage of 1.23VDC. When in the 3 T range, a reading of 1.23T produces the same output, 1.23VDC.

The analog output can reach a maximum output of about 4.25VDC in order to accommodate the peak value of a 3VRMS AC signal. This means that the analog output can be used to measure flux density levels that exceed the normal range of the displayed readings. For instance, a level of 31.5mT in the 30mT range would normally result in a flashing 29.99mT overrange condition. However, the output will still be +3.15VDC.

The meter will apply an optimum amount of low pass filtering to the analog output signal based on the frequency of the detected magnetic field and mode of operation (AC or DC mode).



Figure 3-20
Analog Output Display

When both the ANALOG OUTPUT and AUTO RANGE features are active the following condition can occur. Suppose the present range is 3kG and the present reading is +2.8kG. The analog output will be +2.8VDC. The signal then increases to +3.2kG, which would force an automatic change to the 30kG range setting. The analog output will now be +0.32VDC because of the range change. This can lead to problems if the analog signal is being used to make decisions since there is no indication that a range change has occurred. In these situations it is best to select a fixed range that covers the expected flux density span.

The analog output signal contains both the DC and AC components of the flux density signal. This means that it will also contain any initial DC offsets in the probe and the meter's circuitry. These offsets can be removed by the ZERO function.

The ZERO function can also be used to introduce a DC offset if desired. This is useful when observing AC waveforms in which one portion of the waveform is being clipped because it exceeds the 4.25VDC limit of the meter. Using the ZERO function, the center of the waveform can be moved to reduce or eliminate the "clipping" as depicted in the figure below.

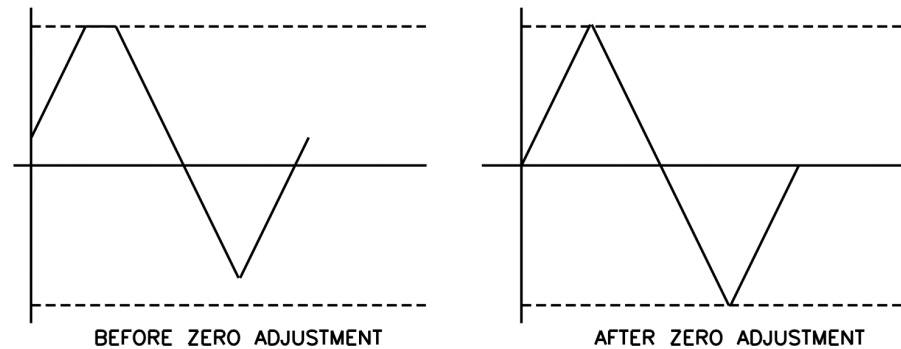

Figure 3-21
Adjusting the DC Offset of the Analog Output

SOURCES OF MEASUREMENT ERRORS

When making flux density measurements there are several conditions that can introduce error:

1) Operating the meter while the LOW BATTERY symbol appears.

Instrument specifications are not guaranteed when a low battery condition exists!

2) Failure to zero the error signals from the meter, probe, and nearby sources of magnetic interference.

3) Subjecting the probe to physical abuse.

4) One of the most common sources of error is the angular position of the probe with respect to the field being measured. As mentioned in Section 1, a Hall generator is not only sensitive to the number of flux lines passing through it but also to the angle which they pass through it. The Hall generator produces the greatest signal when the flux lines are perpendicular to the sensor as shown in Figure 3-22.

The probe is calibrated and specified with flux lines passing perpendicularly through the Hall generator.

5) As shown in Figure 3-23 the greater the distance between the magnetic source and the Hall probe, the fewer flux lines will pass through the probe. This would cause the probe's output to decrease.



Handle the Hall probe with care. Do not bend the stem or apply pressure to the probe tip as damage may result. Use the protective cover when the probe is not in use.

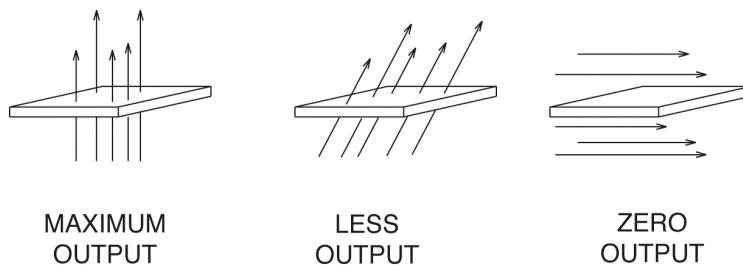

Figure 3-22
Probe Output versus Flux Angle

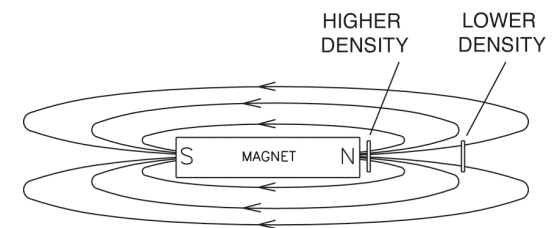

Figure 3-23
Probe Output versus Distance

6) Flux density can vary considerably across the pole face of a permanent magnet. This can be caused by internal physical flaws such as hairline cracks or bubbles, or an inconsistent mix of materials. Generally the sensitive area of a Hall generator is much smaller than the surface area of the magnet, so the flux density variations are very apparent. Figure 3-24 illustrates this situation.

7) The accuracies of the meter and probe are affected by temperature variations. Refer to the SPECIFICATIONS section for the specific information.

MORE DETAILS ON AC MODE OPERATION

It is possible for the flux density signal to contain both a DC component and an AC component. In the AC mode, the value displayed is the true RMS value of the waveform with its DC component removed. However, if the DC component is too high it may force the peak value of the waveform to exceed the electrical limits of the meter. This could cause the waveform to clip and introduce errors in the final reading. This can also lead to an overrange condition on the display and can lead to erratic behavior if the AUTO RANGE feature is active. The presence of a clipped AC signal can be verified by observing the analog output signal.

As stated in the SPECIFICATION section, the accuracy of the true RMS reading is only guaranteed for readings greater than about 4% of the full scale range. For example, this would be 1mT in the 300mT range. Select a lower range if possible to maintain accuracy. Refer to page 3-18 and figure 3-21 for more detailed information about reducing this type of error. Clipped signals can also occur when observing higher frequency signals (typically >10 kHz) in the upper 30% of the selected range, (especially with a transverse probe). In this case the next higher range should be used.

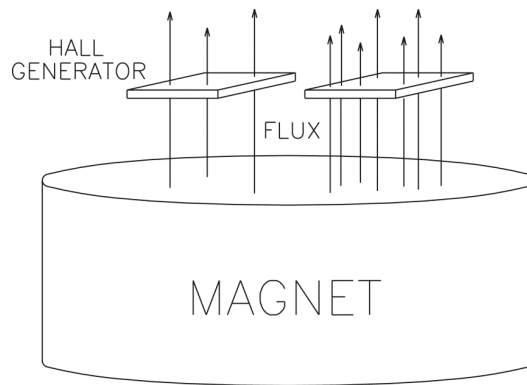

The use of some lower quality or unshielded cables can result in measurement errors and increase susceptibility to radio frequency interference (RFI).

Figure 3-24
Flux Density Variations in a Magnet

An AC reading, being a true RMS value, has no polarity. However, when using the RELATIVE function in AC mode, a negative value may be displayed. A negative AC reading means that the present reading is less than the RELATIVE value. An unsigned value means the present reading is greater than or equal to the RELATIVE value. For example, if the original RELATIVE value was 100mT and the present field is 80mT, the result will be -20mT.

MORE DETAILS ON DC MODE OPERATION

It is possible for the flux density signal to contain both a DC component and an AC component. In the DC mode this can lead to unstable readings. If the peak value of the AC component reaches the electrical limits of the meter, even though the average DC level is within the limits, an overrange condition may appear on the display. This situation can also lead to erratic behavior if the AUTO RANGE feature is active.

The presence of an AC signal can be verified by observing the analog output signal or by using the AC mode to determine the magnitude of the AC component.

Section 4

Remote Operation

USB INTERFACE CONNECTION

NOTE: Ensure that sleep mode is disabled prior to remote operation.

Prior to using the remote operation capability of the meter, the USB driver software must be installed on a computer. This software was supplied on the User's Manual CD for the meter, however newer software may be available. Please visit the F.W. Bell web site, to download the latest software for the 5100 series meters, and follow the instructions on the web site for installation.

REMOTE COMMAND STANDARDS

Prior to 1987 most instruments that featured RS232 communications interfaces had their own unique commands for exchanging information. Eventually some manufacturers began offering models that recognized other manufacturer's commands so that customers could easily switch over without making extensive changes to their programs.

The IEEE-488-1987.2 standard (also called "IEEE-488.2") was one step toward creating a universal way to communicate with any instrument, regardless of the manufacturer or the type of instrument used. This was later enhanced by the SCPI1991 Standard (Software Commands for Programmable Instruments), which defined specific commands and responses that covered a broad range of applications. Though these standards were targeted for use with the IEEE488 instrumentation bus they are commonly used with serial (RS232) interfaces as well.

The Model 5180 supports many of the IEEE-488-1987.2 "common" commands as well as a subset of the SCPI-1991 commands.

COMMAND FORMAT

All commands consist of ASCII character strings. Some commands contain numeric parameters that are used to set or reset individual bits within binary registers. For instance a value of 45 decimal is the same as binary 101101, thus setting bits 5, 3, 2 and 0 in the register and resetting all others. Sending the value "00101101" would be interpreted as the number 101,101.

NOTE: No more than 500 characters can be sent in one command string.

ERROR BUFFER

Errors are generated by a variety of sources, such as hardware errors or errors in the command syntax. If an error occurs a message is stored in an ERROR BUFFER. The message can be retrieved by a specific command discussed later in this section.

STATUS REGISTERS

There are four register sets that indicate the status of the instrument, such as errors or the present state of the meter. These are 8bit registers, but in many cases not all of the bits are used. The four register sets are called

MEASUREMENT EVENT
OPERATION EVENT
STANDARD EVENT
QUESTIONABLE EVENT

There is also an 8-bit register that provides a 1-bit summary for each of the four register sets. This is called the STATUS BYTE. Each register set consists of three individual registers, as depicted in Figure 4-3 (next page).

- 1) The CONDITION register is a real time, read only register that is constantly updated to reflect current operating conditions.
- 2) The EVENT register is fed by the CONDITION register, but operates as a latch. Whenever any bit in the CONDITION register goes to "1", a corresponding "1" is latched into the EVENT register and remains that way until cleared by a specific command.
- 3) The ENABLE register is a mask register that is used to generate the single status bit for the STATUS BYTE. Setting any bit in the ENABLE register to "1" will allow a corresponding "1" in the EVENT register to set the summary bit in the STATUS BYTE.

Information for Remote Operation of 5180 Gaussmeter

There are 2 DLL files which should be installed when you run the setup program from the 5180 User manual CD. They are libusb0.dll and usb5100.dll.

They should have installed to your system when you ran the installation from the CD.

Note: These files allow communication with the 5180 by higher level programming languages such as various types of C, C++ or C#, VisualBasic or development programs like LabView, Agilent VEE or TestPoint which can make calls to a DLL file. The function definitions are given near the bottom of this page. The earlier versions of the software may not work with an Intel dual core processor.

There are 3 functions in the usb5100.dll you will need to call to communicate with the 5180.

1. The first is "openUSB5100" and returns a 4 byte integer (unsigned long in C) which is the USB handle for the device being communicated with. You may communicate with more than one 5180, but you will need to keep track of the handle for each unit because the handle must be passed to the other 2 functions when calling them.

Example: call "**openUSB5100**" and it should return a value, for example 10203045 or some other number.

2. The second function is the one you will use to do all other communication, except for closing the session with the 5180.

It is "scpiCommand" and requires 4 arguments to be passed when calling.

a. The USB ID number assigned when the device was opened initially. (the handle returned by openUSB5100)

b. The SCPI command string (the text string for the desired command as given in the user manual Remote Operation and SCPI command sections)

c. Pointer to the object where you want the response returned to.
(this should be a pointer to a string variable)

d. Maximum response string length. Default is 80 and this should be good for most applications.

Example: **scpiCommand(102030405, *IDN?, pointer to ResponseString variable, 80)**

3. The third function will close the USB session with the 5180.

It is "closeUSB5100" and does not return anything.

Example: **closeUSB5100(102030405)**

Below are the function definitions for these:

FWB5180.h

```
// The following ifdef block is the standard way of creating macros which make exporting
// from a DLL simpler. All files within this DLL are compiled with the USB5100_EXPORTS
// symbol defined on the command line. this symbol should not be defined on any project
// that uses this DLL. This way any other project whose source files include this file see
// USB5100_API functions as being imported from a DLL, whereas this DLL sees symbols
// defined with this macro as being exported.
```

```
#ifndef USB5100_EXPORTS
#define USB5100_API __declspec(dllexport)
#else
#define USB5100_API __declspec(dllimport)
#endif
```

```
extern "C" USB5100_API unsigned int openUSB5100(void);
extern "C" USB5100_API void closeUSB5100(unsigned int fwb5000ID);
extern "C" USB5100_API int scpiCommand(unsigned int usbID,
char* cmd, char* result, int len);
```

Other General 5180 File Information

The basic calling sequence of executable and DLL files in the 5180 installation is as follows:

- PC5180.EXE is an executable application that provides the graphical meter interface on the computer's monitor. This may be useful for some simple remote monitoring applications etc., but is not very useful for integrating a 5180 into any sort of automated system or testing environment via any generic programming language. PC5180.EXE calls functions that are exported by lib5100.DLL.
- Lib5100.DLL exports a collection of .NET classes that handle the high level connection and display functions. It calls functions that are exported by usb5100.DLL.
- Usb5100.DLL exports many functions that actually do the USB connection and communication with the 5180 meter. This is the DLL that provides the functions used by the Sypris manufacturing test & calibration system. It calls functions that are exported by libusb0.dll. The functions in this DLL should be able to be called by most higher level programming languages using the methods described earlier in this document.
- Libusb0.DLL is part of the device driver package and exports very low-level generic USB access functions. These are not specific to the 5180 and would not likely do our customers much good in their development of software to communicate with the 5180.
This is an open source project and info is available on the web at:
<http://libusbwin32.sourceforge.net/> and probably several other related sites if the customer has a need for this information.

STATUS BYTE AND REQUEST FOR SERVICE (RQS)

A bit in the STATUS BYTE called RQS (request for service) sets whenever an event occurs that requires the attention of the computer. The RQS bit can set if any of the summary bits from the MEASUREMENT EVENT, OPERATION EVENT, STANDARD EVENT or QUESTIONABLE EVENT registers are set, or if an error message exists. The STATUS ENABLE register is a mask register that is used to allow any of these conditions to set the RQS bit. Setting any bit in the STATUS ENABLE register to “1” will allow a corresponding “1” in the STATUS BYTE register to set the RQS bit. These registers are depicted in Figure 4-4.

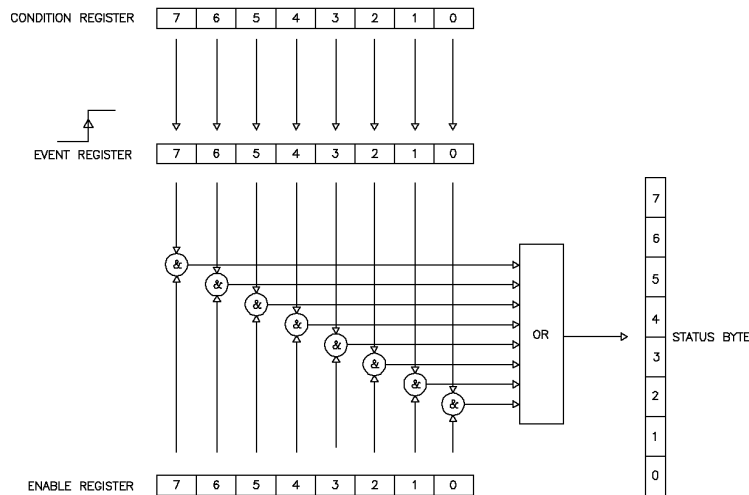

Figure 4-3
Condition, Event and Enable registers

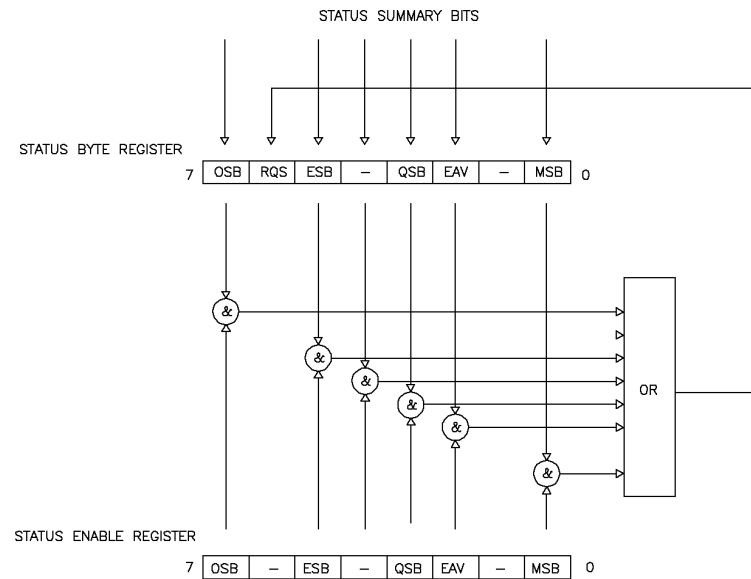

Figure 4-4
Status Byte and Enable registers

OSB – Operation Summary Bit:

If any of the bits in the OPERATION EVENT register set, and their respective enable bits are set, the Operation Summary Bit (OSB) will set.

ESB – Event Summary Bit:

If any of the bits in the STANDARD EVENT register set, and their respective enable bits are set, the Event Summary Bit (ESB) will set.

QSB – Questionable Summary Bit:

If any of the bits in the QUESTIONABLE EVENT register set, and their respective enable bits are set, the Questionable Summary Bit (QSB) will set.

MSB – Measurement Summary Bit:

If any of the bits in the MEASUREMENT EVENT register set, and their respective enable bits are set, the Measurement Summary Bit (MSB) will set.

EAV – Error Available:

This bit sets any time there is an error message available in the error buffer.

RSQ – Request For Service:

If any of the other bits in the STATUS BYTE are set, and their respective enable bits are set in the STATUS ENABLE register, the Request For Service (RQS) will set.

STANDARD EVENT REGISTER

If any of these bits set, and their respective enable bits are set, the Event Summary Bit (ESB) will set in the STATUS BYTE.

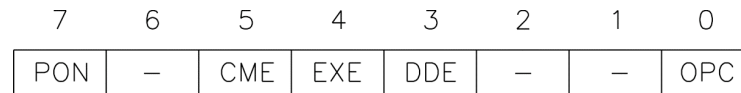

Figure 4-5
Standard Event register

PON–Power On:

Indicates that the meter was turned off and on since the last communication.

CME – Command Error:

Indicates that there was a syntax or spelling error in the command, or the command received is not supported.

EXE – Execution Error:

Indicates that the meter detected an error while attempting to execute a command.

DDE – Device Dependent Error:

Indicates that the meter did not operate properly due to some internal error.

OPC – Operation Complete:

Indicates that all requested operations have been completed.

MEASUREMENT EVENT REGISTER

If any of these bits set, and their respective enable bits are set, the Measurement Summary Bit (MSB) will set in the STATUS BYTE.

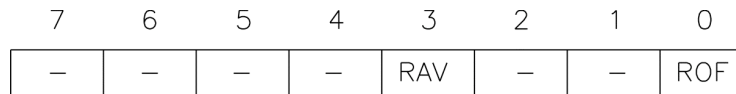

Figure 4-6
Measurement Event register

ROF – Reading Overflow:

Indicates that the present reading exceeds the present measurement range.

RAV – Reading Available:

Indicates a reading was acquired and processed.

OPERATION EVENT REGISTER

If any of these bits set, and their respective enable bits are set, the Operation Summary Bit (OSB) will set in the STATUS BYTE.



Figure 4-7
Operation Event register

MEAS – Measure mode:

Indicates the meter is in the process of acquiring and processing a reading.

QUESTIONABLE EVENT REGISTER

If any of these bits set, and their respective enable bits are set, the Questionable Summary Bit (QSB) will set in the STATUS BYTE.

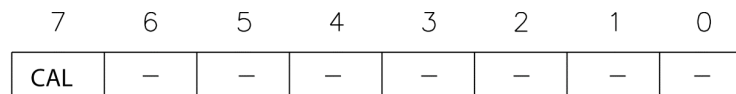

Figure 4-8
Questionable Event register

CAL – Calibration summary:

Indicates that an invalid calibration constant was detected during power up or when the probe was installed. The instrument will instead use a default parameter. This bit will clear once the meter and probe have been successfully calibrated.

NOTE: Meter specifications are not guaranteed when the CAL bit is set !

“COMMON” COMMAND SYNTAX

The “common” commands are recognized and acted upon in a similar manner by all instruments that follow the IEEE488.2 standard, whether a DVM, scope, frequency meter, gaussmeter, etc. These are the syntax rules:

- 1) A common command always begins with an asterisk character (*) followed by a three or four character acronym and possibly one other parameter. For instance the command to clear the event registers is *CLS.
- 2) The commands are not case sensitive. For instance the *CLS, *cls and *cLS commands are identical.
- 3) If there is a fourth character in the acronym it will always be a question mark (?) and indicates that information is being requested from the instrument. For instance a command to read the model number and manufacturer of the instrument is *IDN?.
- 4) If a parameter follows a command it must be separated from the acronym by one space. The parameter is the ASCII representation of an integer. For instance if the parameter to be sent is binary 1100, the actual parameter sent would be the two ASCII characters 12, since binary 1100 = decimal 12. If you were to send the four ASCII characters 1100 it would be interpreted as decimal 1100 (eleven hundred).
- 5) A number returned from the instrument is an ASCII representation of a number. For instance if the instrument returns the ASCII string 345 the number is decimal 345 (three hundred forty five), which translates to 159 hex.
- 6) Multiple commands can be sent in one string. The commands must be separated by semicolons (;). For instance, *CLS;*IDN? first clears the event registers and then requests model and manufacturer information. If more than one of the commands in the string requests information from the instrument, the instrument’s response will also have semicolons separating the responses, such as 345;0;10.

“COMMON” COMMANDS

ACRONYM	NAME	BRIEF DESCRIPTION
*CLS	Clear status	Clear all event registers and error buffer.
*ESE <NRf>	Program event enable	Program standard event enable register.
*ESE?	Event enable query	Read standard event enable register.
*ESR?	Event status query	Read standard event register and clear it.
*IDN?	Identification query	Return manufacturer, model number, software version number.
*OPC	Set operation complete	Set the Operation Complete bit in the standard event register after all commands have been executed.
*OPC?	Operation complete query	Returns an ASCII “1” after all commands have been executed.
*OPT?	Option identification query	Returns information about the attached Hall probe.
*SRE <NRf>	Program Status enable	Program STATUS enable register.
*SRE?	Status enable query	Read STATUS enable register.
*STB?	Status byte query	Read status byte register.

Table 4-1
Common command summary

***CLS – CLEAR STATUS**

Clears the MEASUREMENT EVENT, OPERATION EVENT, STANDARD EVENT and QUESTIONABLE EVENT registers, but not their enable registers. It also clears the error buffer.

***ESE <NRf> – PROGRAM STANDARD EVENT ENABLE REGISTER**

A set bit in the STANDARD EVENT ENABLE register allows its corresponding event to set the ESB (event summary bit) in the STATUS BYTE register. <NRf> is an ASCII string representing an integer mask. For instance a value of 45 decimal is the same as binary 00101101, thus setting bits 5, 3, 2 and 0 in the enable register.

***ESE? – STANDARD EVENT ENABLE REGISTER QUERY** Returns the contents of the STANDARD EVENT ENABLE register.

***ESR? – STANDARD EVENT REGISTER QUERY** Returns the contents of the STANDARD EVENT register.

NOTE: The STANDARD EVENT register is cleared after an *ESR? command.

***IDN? – IDENTIFICATION QUERY**

Returns the following string: F.W.BELL, MODEL 5180,Rx.x. The Rx.x string is the firmware revision level, where x.x is a decimal number, such as 1.1.

***OPC – SET OPERATION COMPLETE**

Causes the OPC (operation complete) bit to set in the STANDARD EVENT register when all commands have been executed.

***OPC? – OPERATION COMPLETE QUERY**

Causes the OPC (operation complete) bit to set in the STANDARD EVENT register and returns an ASCII “1” when all commands have been executed.

***OPT? – OPTION IDENTIFICATION QUERY**

Returns a string that identifies the model number and serial number of the Hall probe. The model number will always be 12 characters in length including trailing spaces, such as STD580404. Following the model number will be a comma (.). Next will be the serial number, which will always be ten characters in length including trailing spaces, such as 0523004. If no probe is attached or can't be identified the string will default to “UNDEFINED ,0”.

***SRE <NRf> – PROGRAM STATUS ENABLE REGISTER**

A set bit in the STATUS ENABLE register allows its corresponding event to set the RQS (request for service) in the STATUS BYTE register. <NRf> is an ASCII string representing an integer mask. For instance a value of 45 decimal is the same as binary 00101101, thus setting bits 5, 3, 2 and 0 in the enable register.

***SRE? – STATUS ENABLE REGISTER QUERY** Returns the contents of the STATUS ENABLE register.

***STB? – STATUS BYTE QUERY** Returns the contents of the STATUS BYTE register.

NOTE: The STATUS BYTE register is not cleared after an *STB? command.

Other registers and buffers must be cleared for the bits in the STATUS BYTE register to be cleared.

SCPI COMMAND SYNTAX

The SCPI commands go one step farther than IEEE488.2 and provide a language protocol and defines a standard set of commands to program most aspects of the instrument. These are the syntax rules:

- 1) The first character of any command string is a colon (:).
- 2) The commands are not case sensitive. For instance the :MEASURE, :measure and :MEASure commands are identical.
- 3) A question mark (?) in a command means that the command is requesting information from the instrument. This is called a query command.
- 4) For any command there is a short and long spelling of the command. Use the following rules for the short version:
 - a) If the length of the command is four letters or less, there is no short version.
 - b) If the command has more than four letters and the fourth letter is a vowel, drop it and all letters that follow it. For instance the command :RESET can be shortened to :RES.
 - c) If the command has more than four letters and the fourth letter is a consonant, drop all letters that follow it. For instance the command :MEASURE can be shortened to :MEAS.
 - d) If the command contains a question mark (?) or a non-optional parameter it must be included after the short form version. For instance a query command of :CONDITION? can be shortened to :COND?.
 - e) The use of anything other than the short or long version of a command is not permitted. For instance both the :MEASURE and :MEAS commands are acceptable, but :MEASU is not.
- 5) **If a parameter follows a command it must be separated from the command by one space.**
- 6) Multiple commands can be sent in one string. The commands must be separated by semicolons (;). A colon (:) must still precede each command. If more than one of the commands in the string requests information from the instrument, the instrument's response will also have semicolons separating the responses, such as 345;0;10.

SCPI COMMANDS

In the following discussion the commands are written such that the short form of the command is written in UPPER CASE letters and the remainder of the command is written in lower case letters.

Either form can be used.

If parameters are required they will appear within <> brackets in this document. Brackets are not part of the actual command string.

An <n> parameter is a single ASCII digit. <NRf> is usually a multiple digit number. The meter supports a subset of the available SCPI commands. However, there are some functions that are not supported with standard SCPI commands. In these cases these special commands are patterned after other SCPI commands that are similar in function.

SPCI Commands continued on next page

ERROR MESSAGE COMMANDS	DESCRIPTION
:SYSTem:ERRor?	Retrieve next error message
:SYSTem:CLEar	Clear all error messages
STATUS REGISTER COMMANDS	DESCRIPTION
:STATus:MEASurement:EVENT?	Query Measurement Event reg.
:STATus:OPERation:EVENT?	Query Operation Event reg.
:STATus:QUESTionable:EVENT?	Query Questionable Event reg.
:STATus:MEASurement:ENABLE <NRf>	Program Measurement Event Enable reg.
:STATus:OPERation:ENABLE < NRf>	Program Operation Event Enable reg.
:STATus:QUESTionable:ENABLE <NRf>	Program Questionable Event Enable reg.
:STATus:MEASurement:ENABLE?	Query Measurement Event Enable reg.
:STATus:OPERation:ENABLE?	Query Operation Event Enable reg.
:STATus:QUESTionable:ENABLE?	Query Questionable Event Enable reg.
:STATus:MEASurement:CONDition?	Query Measurement Condition reg.
:STATus:OPERation:CONDition?	Query Operation Condition reg.
:STATus:QUESTionable:CONDition?	Query Questionable Condition reg.
:STATus:PRESet	Clear all event registers.

Table 4-2
SCPI Commands

MODE COMMANDS	DESCRIPTION	ZERO / RELATIVE COMMANDS	DESCRIPTION
:UNIT:FLUX:AC:GAUSs	Program ac gauss mode	:SYSTem:AZERo	Initiates an automatic zero operation
:UNIT:FLUX:AC:TESLa	Program ac tesla mode	:SYSTem:ARELative:STATe <n>	Program relative mode
:UNIT:FLUX:AC:AM	Program ac amp-meter mode	:SYSTem:ARELative:STATe?	Query relative mode setting
:UNIT:FLUX:DC:GAUSs	Program dc gauss mode		
:UNIT:FLUX:DC:TESLa	Program dc tesla mode		
:UNIT:FLUX:DC:AM	Program dc A-M mode		
:UNIT:FLUX?	Query mode setting		
RANGE COMMANDS	DESCRIPTION	MEASUREMENT COMMANDS	DESCRIPTION
:SENSe:FLUX:RANGe:AUTO	Program auto range	:MEASure:FLUX?	Obtain flux density reading.
:SENSe:FLUX:RANGe <n>	Program fixed range		
:SENSe:FLUX:RANGe?	Query range setting		
HOLD COMMANDS	DESCRIPTION	ANALOG OUTPUT COMMANDS	DESCRIPTION
:SENSe:HOLD:STATe <n>	Program hold mode	:SYSTem:OUT <n>	Enable / disable analog output.
:SENSe:HOLD:STATe?	Query hold mode setting		
:SENSe:HOLD:RESet	Reset presently held value		

Table 4-2
SCPI Commands

ERROR MESSAGES AND COMMANDS

If an error occurs a message is placed in the error buffer. The message will contain a number, a comma (,) and a brief description of the error. Negative () numbers are used for SCPI defined messages while positive (+) numbers relate specifically to the meter.

Each time the buffer is read the next error message is returned and then removed from the buffer. If no error exists the message "0, No error" will be returned.

There are certain error status bits that will set in the STANDARD EVENT register. These bits provide general error indications. The error message will provide more detailed information about the errors.

The error buffer can be read and cleared with the following commands:

:SYSTem:ERRor?

Returns the next error message and removes it from the error buffer.

:SYSTem:CLEar

Removes all messages from the error buffer.

If the meter detects an error in the command string (a spelling error, a command that is not supported or a numerical value that is incorrect) the meter will not execute the command. If the error is detected in the middle of a multiple command string the command that contains the error and all commands that follow will not be executed. The user's program should always check the STATUS BYTE to determine if an error has occurred.

ERROR CODE LIST

0,	NO ERROR
-201,	NOT IN MEASURE MODE
-120,	NUMERIC DATA ERROR
-224,	ILLEGAL PARAMETER ERROR
-363,	INPUT BUFFER OVERRUN
-103,	INVALID SEPARATOR
-102,	SYNTAX ERROR
-100,	COMMAND ERROR
3,	INVALID METER CAL DATA
40,	UNABLE TO READ PROBE CAL DATA
43,	INVALID PROBE CAL DATA
44,	INVALID PROBE CAL DATA
45,	INVALID PROBE CAL DATA
98,	INVALID PROBE CAL DATA
99,	METER CALIBRATION ERROR
60,	METER CALIBRATION ERROR
61,	METER CALIBRATION ERROR
62,	METER CALIBRATION ERROR
63,	METER CALIBRATION ERROR
64,	METER CALIBRATION ERROR
65,	METER CALIBRATION ERROR
66,	METER CALIBRATION ERROR
67,	METER CALIBRATION ERROR

STATUS COMMANDS

The STATUS commands control and query the MEASUREMENT EVENT, OPERATION EVENT and QUESTIONABLE EVENT registers.

:STATus:MEASurement:EVENT?

:STATus:OPERation:EVENT?

:STATus:QUESTionable:EVENT?

Returns the contents of the specified EVENT register, then clears the register contents.

:STATus:MEASurement:ENABLE <NRf>

:STATus:OPERation:ENABLE <NRf>

:STATus:QUESTionable:ENABLE <NRf>

Programs the specified EVENT ENABLE register with the value <NRf>. <NRf> is an ASCII string representing an integer mask. For instance a value of 45 decimal is the same as binary 00101101, thus setting bits 5, 3, 2 and 0 in the enable register.

:STATus:MEASurement:ENABLE?

:STATus:OPERation:ENABLE?

:STATus:QUESTionable:ENABLE?

Returns the contents of the specified EVENT ENABLE register.

:STATus:MEASurement:CONDition?

:STATus:OPERation:CONDition?

:STATus:QUESTionable:CONDition?

Returns the contents of the specified EVENT CONDITION register. The EVENT CONDITION register is a realtime register reflecting the state of the meter at the time of the read. Some conditions could happen very quickly and could be missed by this query. It is often better to rely on the contents of the EVENT register since it latches the event until cleared by a specific command.

:STATus:PRESet

Clears all EVENT ENABLE registers.

MODE COMMANDS

These commands select readings in either GAUSS, TESLA or AMPMETERS, and flux density readings for either static fields (dc) or alternating fields (ac). See Section 3 for more information.

:UNIT:FLUX:AC:GAUSS Specifies ac flux density readings in gauss.

:UNIT:FLUX:AC:TESLa

Specifies ac flux density readings in tesla.

:UNIT:FLUX:AC:AM

Specifies ac flux density readings in ampmeters.

:UNIT:FLUX:DC:GAUSS

Specifies dc flux density readings in gauss.

:UNIT:FLUX:DC:TESLa

Specifies dc flux density readings in tesla.

:UNIT:FLUX:DC:AM

Specifies dc flux density readings in ampmeters.

:UNIT:FLUX?

Returns an ASCII string representing the present mode setting for the meter. The ASCII string can be DC GAUSS, AC GAUSS, DC TESLA, AC TESLA, AC AM or DC AM.

RANGE COMMANDS

These commands select either a fixed range or AUTO range. See Section 3 for more information.

:SENSe:FLUX:RANGe:AUTO

Selects the AUTO RANGE function.

:SENSe:FLUX:RANGe <n>

Selects a fixed range <n>, where n =

0 for 300 G / 30 mT / 23.88 kA/m

1 for 3 kG / 300 mT / 238.8 kA/m

2 for 30 kG / 3 T / 2388 kA/m

:SENSe:FLUX:RANGe?

Returns an ASCII digit representing the present range setting for the meter, as follows:

0 for 300 G / 30 mT / 23.88 kA/m

1 for 3 kG / 300 mT / 238.8 kA/m

2 for 30 kG / 3 T / 2388 kA/m

HOLD COMMANDS

These commands select one of the HOLD modes or resets the presently held reading. See Section 3 for more information.

:SENSe:HOLD:STATe <n>

Selects the HOLD function, where <n> is a single ASCII digit, as follows:

0 = All HOLD modes turned off.

1 = MIN HOLD on.

2 = MAX HOLD on.

3 = PEAK HOLD on.

:SENSe:HOLD:STATe?

Returns an ASCII digit representing the present HOLD mode setting, as follows:

0 = All HOLD modes turned off.

1 = MIN HOLD on.

2 = MAX HOLD on.

3 = PEAK HOLD on.

:SENSe:HOLD:RESet

This command resets the presently held reading.

ZERO COMMAND

This command initiates an automatic ZERO operation. See Section 3 for more information.

:SYSTem:AZERo

Automatic zeroing is initiated upon receipt of this command.

RELATIVE COMMANDS

These commands control the RELATIVE function. See Section 3 for more information.

:SYSTem:ARELative:STATe <n>

The relative function is turned off when <n> is 0. When <n> is 1 the relative function is turned on, using the previously generated relative value, if any. When <n> is 2 the relative function is turned on and an automatic relative operation is initiated.

:SYSTem:ARELative:STATe?

Returns a single ASCII digit indicating the on / off state of the relative function. A 0 indicates the relative function is turned off. A 1 indicates the relative function is turned on.

MEASUREMENT COMMAND

This command acquires a new flux density reading.

:MEASure:FLUX?

This command returns the latest flux density reading. The returned string will contain a signed real number and a unit indicator (G, T, or Am). If in the ac mode the reading will not contain a polarity character (+ or -).

The ranges of possible readings for the various units of measure are:

0.0G to 29990G
0.00000T to 2.999T
0Am to 2,388,000Am

ANALOG OUTPUT COMMAND

This command enables or disables the ANALOG OUTPUT. See Section 3 for more information.

:SYSTem:OUT <n>

Enables or disables the ANALOG OUTPUT, where <n> is a single ASCII digit, as follows:

0 = Analog output turned off.

1 = Analog output turned on.

2 = Analog output turned on.

Note: "2" is an obsolete argument but still supported for backward compatibility with customer's existing software.

INTERMIXING "COMMON" AND SCPI COMMANDS

As mentioned earlier a string sent to the instrument can contain more than one command as long as the commands are separated by semicolons(;). "Common" and SCPI commands can be intermixed. For instance the string:

*CLS;;UNIT:FLUX:DC:TESLA;;MEASure:FLUX?

is valid, first clearing the instrument's event and error registers, then programming it to supply readings in tesla in the dc mode and requesting the latest reading. The host system should be prepared to receive the reading immediately after transmitting this command string to the meter.

USING QUERY COMMANDS

When any query command is issued the meter will send its response back immediately. However if a query command is part of a multiple command string the meter will transmit the response after all commands within the string have been executed. For instance here is such a string:

:UNIT:FLUX:DC:GAUSS;;MEAS:FLUX?;;UNIT:FLUX:DC:TESLA;;MEAS:FLUX?

In this string the meter is programmed for DC GAUSS mode and a measurement is requested. Then the meter is programmed for DC TESLA mode and another measurement is requested. When the meter has finished executing the entire command string it will transmit a string similar to this: +1892G;+0.1892T.

USING THE OPERATION COMPLETE STATUS

There are several ways to determine if the meter has executed a command. If the command string contains a query command the program can simply wait for the meter to transmit its response. But if the query command contains an error the command may never be executed. Further, some commands do not require a response. The best way to handle all situations is to issue the *OPC? command once prior to sending any other commands. This will cause the meter to always transmit an ASCII "1" each time it executes a command string. If the command string contains one or more query commands, the "1" will be appended to the end of the response separated by a semicolon (;). For instance the response to the command string

```
*OPC?;;UNIT:FLUX:AC:GAUSS
```

would be "1", whereas the response to a command string containing a query

```
*OPC?;;MEAS:FLUX?
```

might be "+221.3G;1

MODEL 5100 ERROR CODES THAT MAY BE DISPLAYED IF THERE IS A PROBLEM

Error Code	Description of Error	Possible problem
003	Invalid calibration data	Meter not calibrated or data corrupt
040	Probe EPROM read error	Probe EPROM missing or defective
043	Probe CRC failed	Probe EPROM defective
044	Incorrect probe current	Probe EPROM error or meter malfunction
045	Probe CRC failed	Probe EPROM not programmed
098	Probe data timeout	Internal meter error
099	Calibration data timeout	Internal meter messaging / reset problem
060	ADC error	Internal meter problem
061	AD zero error	Internal meter problem
062	PIC-DSP com error	Internal meter problem
063	DAC offset error	Internal meter problem
064	Probe current error	Broken probe or meter problem
065	Output DAC error	Internal meter problem
066	Amplifier gain error	Internal meter problem
067	High input resistance	Broken probe or meter problem

Most errors result from a damaged probe. If an error code for a probe related type of problem appears, substitute another probe if one is available.

WARRANTY

This instrument is warranted to be free of defects in material and workmanship. Sypris Test & Measurement's obligation under this warranty is limited to servicing or adjusting any instrument returned to the factory for that purpose, and to replace any defective parts thereof. This warranty covers instruments which, within one year after delivery to the original purchaser, shall be returned with transportation charges prepaid by the original purchaser, and which upon examination shall disclose to Sypris Test & Measurement's satisfaction to be defective. If it is determined that the defect has been caused by misuse or abnormal conditions of operation, repairs will be billed at cost after submitting an estimate to the purchaser.

Sypris Test & Measurement reserves the right to make changes in design at any time without incurring any obligation to install same on units previously purchased.

THE ABOVE WARRANTY IS EXPRESSLY IN LIEU OF ALL OTHER WARRANTIES EXPRESSED OR IMPLIED AND ALL OTHER OBLIGATIONS AND LIABILITIES ON THE PART OF SYPRIS TEST & MEASUREMENT, AND NO PERSON INCLUDING ANY DISTRIBUTOR, AGENT OR REPRESENTATIVE OF SYPRIS TEST & MEASUREMENT IS AUTHORIZED TO ASSUME FOR SYPRIS TEST & MEASUREMENT ANY LIABILITY ON ITS BEHALF OR ITS NAME, EXCEPT TO REFER THE PURCHASER TO THIS WARRANTY. THE ABOVE EXPRESS WARRANTY IS THE ONLY WARRANTY MADE BY SYPRIS TEST & MEASUREMENT. SYPRIS TEST & MEASUREMENT DOES NOT MAKE AND EXPRESSLY DISCLAIMS ANY OTHER WARRANTIES, EITHER EXPRESSED OR IMPLIED, INCLUDING WITHOUT LIMITING THE FOREGOING, WARRANTIES OF MERCHANTABILITY OR FITNESS FOR A PARTICULAR PURPOSE OR ARISING BY STATUE OR OTHERWISE IN LAW OR FROM A COURSE OF DEALING OR USAGE OR TRADE.

THE EXPRESS WARRANTY STATED ABOVE IS MADE IN LIEU OF ALL LIABILITIES FOR DAMAGES, INCLUDING BUT NOT LIMITED TO CONSEQUENTIAL DAMAGES, LOST PROFITS OR THE LIKE ARISING OUT OF OR IN CONNECTION WITH THE SALE, DELIVERY, USE OR PERFORMANCE OF THE GOODS. IN NO EVENT WILL SYPRIS TEST & MEASUREMENT BE LIABLE FOR SPECIAL, INDIRECT OR CONSEQUENTIAL DAMAGES EVEN IF SYPRIS TEST & MEASUREMENT HAS BEEN ADVISED OF THE POSSIBILITY OF SUCH DAMAGES.

This warranty gives you specific legal rights, and you may also have other rights that vary from state to state.